

Integrating the Healthcare Enterprise



5

**IHE Radiology (RAD)
Technical Framework**

10

**Volume 1x
IHE RAD TF-1x
Appendices**

15

20

**Revision 20.0 – Final Text
March 10, 2022**

25

Please verify you have the most recent version of this document, which is published [here](#).

CONTENTS

30	Appendix A: Clarification of Accession Number and Requested Procedure ID	4
	A.1 Structure of an Order for Imaging Service	4
	Appendix B: Topics for Standards Corrections or Supplements	6
	B.1 HL7 Topics	6
	B.1.1 Version 2.5.1	6
35	B.1.2 HL7 Conformance	6
	B.2 DICOM Topics	6
	Appendix C: Overview of the Information Exchange between Department System Scheduler/Order Filler and Image Manager.....	7
	C.1 Exchange of Patient Information	7
40	C.2 Exchange of Visit and Order Information	7
	C.3 Exchange of Procedure Information	8
	Appendix D: IHE Integration Statements	9
	Appendix E: Nuclear Medicine	10
	E.1 Introduction.....	10
45	E.2 NM Workflow Overview	10
	E.2.1 Injection Steps	11
	E.2.2 Time Separated Acquisitions.....	11
	E.2.3 Reconstruction as a Separate Operation	11
	E.2.4 Acquisition Post-Processing	12
50	E.2.5 Clinical Post Processing	12
	E.2.6 Display and Reviewing.....	13
	E.2.7 Workflow Chaining	13
	E.3 NM Worklists.....	13
	E.3.1 NM Worklist Guidelines.....	13
55	E.3.2 NM Worklist Examples	16
	E.4 NM Data.....	19
	E.4.1 Study UIDs and Series UIDs	20
	E.4.2 NM Image IOD: Multi-Frames and Vectors	21
	E.4.3 Typical NM Data Dimensions.....	21
60	E.5 NM Display.....	23
	E.5.1 NM Intensity and Color Mapping.....	23
	E.5.2 NM Image Resizing	24
	E.5.3 NM Display Examples.....	26
	Appendix F: Security Environment Considerations.....	31
65	Appendix G: Patient Information Reconciliation for XDS-I.b (INFORMATIVE).....	33
	G.1 Context and Assumptions	33
	G.1.1 XDS Affinity Domain Assumptions.....	33
	G.1.2 Metadata in the Document Registry	34
	G.1.3 Patient Identity Management in the XDS Registry	34
70	G.1.4 Expected Implementation Models for Patient Identity Management	34

	G.2 Patient Information Reconciliation (PIR) in an Affinity Domain	35
	G.2.1 Patient Merge within XAD Patient Identity Domain	35
	G.2.2 Local Domain Patient Update - XAD Domain Patient ID does not change.....	36
	G.2.3 Local Domain Patient Update - XAD Domain Patient Merge	37
75	G.2.4 Local Domain Patient Merge – XAD Domain Patient ID does not change	37
	G.2.5 Local Domain Patient Merge – XAD Domain Patient Merge.....	39
	Appendix H: Security considerations for XDS-I.b (informative)	42
	Appendix I: Deployment of Dose Registries	48
	I.1 Dose Registry Deployment Issues	48
80	I.1.1 Code Set Management	48
	I.1.2 Configuration of Secure FTP (Submit Dose Information [RAD-63]).....	48
	I.1.3 Alternative Transport Mechanisms.....	49
	I.1.4 Encapsulated Dose Registry Submission.....	49
	I.2 Real-World Projects.....	50
85	I.3 Dose Monitoring Regulations	51
	GLOSSARY	53

90

Appendix A: Clarification of Accession Number and Requested Procedure ID

95 The purpose of this appendix is to clarify the entity relationships in the Model of Real World adopted by IHE and role of the entity identifiers, such as Accession Number and the Requested Procedure ID, that are used to maintain data consistency between those entities.

A.1 Structure of an Order for Imaging Service

100 There are multiple information systems involved in the fulfillment of the request directed to the imaging department, such as a Radiology Information System (RIS) and a Picture Archiving and Communication System (PACS).

The order for the imaging service is communicated between the Order Placer (such as an Order Entry system) and the Order Filler (such as an RIS). In the imaging department environment, the Order Filler also identifies the set of procedures and sub-procedures (procedure steps) that have to be performed in the process of fulfilling the order. Each procedure step is performed using a single device (modality, workstation). In the process of scheduling the order fulfillment, the Order Filler identifies the type of device and either a specific device or group of devices (for example, by geographic location) one of which is to be used in performing the procedure step.

105 An Order Filler accepts from an Order Placer a single Order that it equates to a Filler Order (which is concept commonly used in HL7^{®1}) or Imaging Service Request (Concept commonly used in DICOM^{®2}). Correspondingly, it will assign a Filler Order Number associated with the order. For the same order to be treated as Imaging Service Request, it will also assign a unique Accession Number. The Accession Number is critical for associating performed procedure steps to the corresponding scheduled procedure steps; therefore, IHE recommends that the Accession Number rather contains no value than an unreliable value, in order to give a human user the opportunity to timely correct this missing value (see also the tables in RAD TF-2x: Appendix A).

115 Each Filler Order may contain one or more Requested Procedures. Each Requested Procedure is identified by a Requested Procedure ID that needs to be unique only within the scope of the Filler Order Number/Accession Number.

120 A Requested Procedure is an instance of a Procedure of a given Procedure Type. An instance of a Requested Procedure includes all of the items of information that are specified by an instance of a Procedure Plan that is selected for the Requested Procedure by the imaging service provider. This Procedure Plan is defined by the imaging service provider on the basis of the Procedure Plan templates associated with the considered Procedure Type. A single Requested Procedure of one Procedure Type is the highest hierarchical unit of work level that may give rise to the creation of a report. Each report is one of the results produced to satisfy the order. For example,

¹ HL7 is the registered trademark of Health Level Seven International and the use does not constitute endorsement by HL7.

² DICOM is the registered trademark of the National Electrical Manufacturers Association for its standards publications relating to digital communications of medical information.

130 in a case of the order for an X-ray examination of a patient daily at 8 am for the next three days, each of the daily examinations will require a separate diagnostic report; hence each of them will be treated as a separate Requested Procedure. In order to support DICOM Query/Retrieve mechanism and easy collation of all results pertaining to a single procedure Order Filler also generates the Study Instance UID, a globally unique identifier for each Requested Procedure. This identifier will be used to identify all generated images and other DICOM objects related to this Requested Procedure.

135 Performance of one instance of a Requested Procedure is specified by exactly one Procedure Plan. Each Requested Procedure may contain one or more Scheduled Procedure Steps that are to be performed according to the Protocols specified by a Procedure Plan. Type and number of Scheduled Procedure Steps in a Requested Procedure is based on the timing and equipment requirements. Each step is identified with the Scheduled Procedure Step ID. A single Procedure Step may only be performed on a single type and instance of equipment. Thus, while the
 140 Requested Procedure may identify multi-modality examination (such as ones common in Nuclear Medicine), a single Procedure Step shall correspond to the operations performed on a single modality.

The example of the hierarchy of Imaging Service Request, Requested Procedure and Scheduled Procedure Step is depicted in a Figure A.1-1. Names of entities are represented by names in bolded text, and their identifiers are represented by names in square brackets.
 145

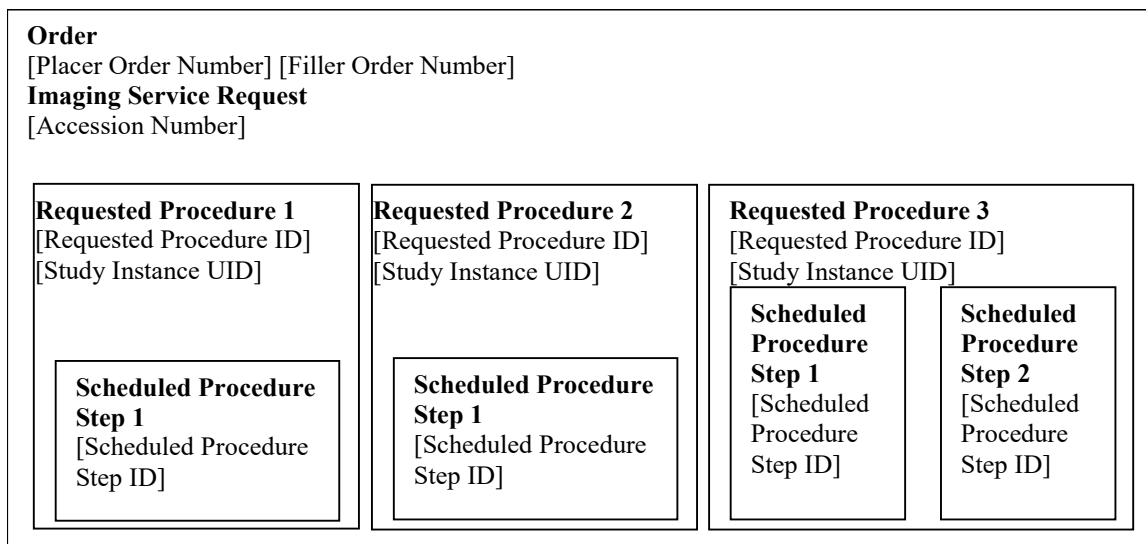

Figure A.1-1: Hierarchy of Components of an Order

150 **Appendix B: Topics for Standards Corrections or Supplements**

B.1 HL7 Topics

B.1.1 Version 2.5.1

155 The IHE Radiology Technical Framework profiles several versions of the HL7 standard (see RAD TF-2: 2.4 for discussion of HL7 Versioning). The IHE profile or option that invokes a transaction will specify the base version of HL7 used, if necessary.

Details needed by IHE Radiology are not always available in all versions of HL7. For example, the Appointment Notification [RAD-48] transaction uses the SIU^S12 message first defined in HL7 Version 2.4 in order to take advantage of the additional scheduling information not available in previous versions.

160 Likewise, IHE has had to provide temporary solutions in custom segments where definitions have not existed. An example is the HL7 v2.3.1 semantics of the [RAD-4] and [RAD-13] transactions which include a ZDS Segment as a temporary solution for handling Study Instance UID. A definition for the Study Instance UID did not exist until HL7 version 2.5 when definitions were added to the OMI (Imaging Order) message.

165 B.1.2 HL7 Conformance

HL7 version 2.5 defines the concepts of HL7 conformance and HL7 profiles that provide standardized mechanism for HL7 specifications. IHE intends to document its definitions of HL7-based transactions using such mechanism. Note that HL7 conformance profiles are not related to IHE Integration Profiles and will be used only for purpose of better documentation of IHE requirements

170

B.2 DICOM Topics

Implementers are expected to keep up with CPs in DICOM as well as in IHE. DICOM CPs may be found here: <http://www.dclunie.com/dicom-status/status.html>

175 **Appendix C: Overview of the Information Exchange between
Department System Scheduler/Order Filler and Image Manager**

Information exchange between the Department System Scheduler/Order Filler and the Image Manager is performed on the intra-departmental level. Each actor manages a distinct domain of information within a department: patient, order and procedure performance information for the
180 Department System Scheduler/Order Filler; image acquisition, storage and interpretation for the Image Manager. Each system, however, requires valid and current information from both domains.

C.1 Exchange of Patient Information

The Department System Scheduler/Order Filler is a source of patient information for the Image
185 Manager within the context of a department. The Image Manager does not receive information for a particular patient until the first order for a patient has been submitted to the department and corresponding procedures have been scheduled. At this point, the Department System Scheduler/Order Filler will communicate patient information to the Image Manager within [RAD-4] Procedure Scheduled.

190 Subsequent updates of patient information are communicated by the Department System Scheduler/Order Filler to the Image Manager via the Patient Update [RAD-12] transaction. These changes will be reflected on the Image Manager and in the images, Grayscale Softcopy Presentation State and Key Image Note objects retrieved from the Image Archive. The Image Manager shall not initiate patient information changes.

195 **C.2 Exchange of Visit and Order Information**

The Department System Scheduler/Order Filler is a source of visit and order information for the Image Manager. The Image Manager does not receive information for a particular patient's visit until the first order for a patient originated within such a visit has been submitted to the
200 department and corresponding procedures have been scheduled. At this point, the Department System Scheduler/Order Filler will communicate visit and order information to the Image Manager within Procedure Scheduled [RAD-4].

Subsequent updates of visit information are communicated by the Department System Scheduler/Order Filler to the Image Manager via Patient Update [RAD-12]. These changes will be reflected on the Image Manager and in the images, Grayscale Softcopy Presentation State and
205 Key Image Note objects retrieved from the Image Archive. The Image Manager shall not initiate visit information changes.

Because the Radiology Technical Framework requires that the order information change will be performed through cancellation of the order in question and re-order, updates of order information are communicated by the Department System Scheduler/Order Filler to the Image
210 Manager via a sequence of two transactions – Procedure Update [RAD-13] (conveying order cancel) and Procedure Scheduled [RAD-4] (conveying new order information). The Image Manager shall not initiate order information changes.

C.3 Exchange of Procedure Information

215 The Department System Scheduler/Order Filler is a source of Requested Procedure information for the Image Manager. The Image Manager does not receive information for a particular procedure until it has been scheduled. At this point, the Department System Scheduler/Order Filler will communicate visit and order information to the Image Manager within Procedure Scheduled [RAD-4].

220 Subsequent updates of procedure information (re-scheduling, change of procedure code, etc.) are communicated by the DSS/Order Filler to the Image Manager via Procedure Update [RAD-13]. The Image Manager shall not initiate Requested Procedure information changes.

225 In the Scheduled Workflow Group Case (RAD TF-2: 4.6.4.1.2.3.4) and Import Reconciliation Workflow Scheduled Import (RAD TF-2x: Table A.5-1), certain imaging information submitted to the Image Manager from the Acquisition Modality or the Importer will differ from that provided by the Department System Scheduler/Order Filler. This information can include the Study Instance UID and the Performed Procedure, Performed Procedure Step and Performed Protocol. For these defined cases this imaging information shall not be subject to change by either the Department System Scheduler/Order Filler or the Image Manager.

230 The behavior for handling the case where the imaging information differs because the Acquisition Modality does not conform to Scheduled Workflow is not defined.

Appendix D: IHE Integration Statements

For details, please see [IHE Technical Framework General Introduction Appendix F: IHE Integration Statements](#).

235 **Appendix E: Nuclear Medicine**

Note that the NM Image Profile is undergoing revision, and vendors considering implementation are advised to include the modifications contained in the trial implementation version “NM Image Profile with Cardiac Option”. For additional information please contact the IHE Radiology Technical Committee at ihe-rad-tech@googlegroups.com.

240 **E.1 Introduction**

This Appendix provides a description of relevant aspects of Nuclear Medicine in the context of the IHE Radiology Technical Framework. This includes descriptions of some typical Nuclear Medicine workflows and how they can be supported within the framework of the current Scheduled Workflow and Post-Processing Workflow Integration Profiles. Characteristics of
245 typical NM Images are presented and examples of typical displays of NM Images are provided.

This Appendix is informative, not normative. The mapping of workflows to the IHE Model, and other details of NM practice are sufficiently complex and/or misunderstood that this Appendix has been included to clarify such issues and provide examples of some sensible approaches. The examples and details here are not intended to be exhaustive. The mappings to the workflow
250 model of IHE shown here are valid but do not represent the only valid mappings.

E.2 NM Workflow Overview

First it should be said that the normal scheduled workflow of:

- registering a patient
- placing an order
- 255 • scheduling an acquisition
- retrieving a worklist at the modality
- performing an acquisition
- generating images
- storing images to the archive
- 260 • retrieving images for review
- generating a report

... is certainly applicable to NM studies.

That being said, it is perhaps most instructive to proceed to describe the ways in which NM workflow can differ from typical radiology workflow and what assumptions may not be valid or
265 may require special consideration for NM.

E.2.1 Injection Steps

270 All nuclear medicine studies depend on the injection of radio-pharmaceutical tracers (although a given series may be imaging a radio-pharmaceutical injected hours or days earlier). Note that although this document refers to injection of the radio-pharmaceutical, it may also be given orally or by some other route.

The required dose of radio-pharmaceutical must be ordered from the pharmacy and delivery arranged to coincide with the scheduled patient procedure. Other aspects include updates for changed or cancelled orders, tracking the radioactive materials, performing QA and confirming the count levels of the delivered dose, etc.

275 The injection procedure step itself is also generally scheduled and its execution logged and tracked both because time from injection factors in to most protocols and because the drug administration should go into the patient record.

280 As will be discussed in the following section on NM Worklist Guidelines, most of these tasks would fall in the scope of yet-to-be-developed profiles relating to Pharmacy and Enterprise Scheduling but the injection step may fall in the scope of Scheduled Workflow.

E.2.2 Time Separated Acquisitions

Standard NM clinical practice includes protocols which require the patient to leave the acquisition equipment between acquisition steps.

285 Some imaging procedures include multiple acquisition steps separated by some time interval. This time interval can be anywhere from 1 or 2 hours, up to as much as a few days. This means that the patient leaves the imaging system in between parts of the procedure. When the patient returns, it is possible that the new acquisitions may be done on a different system based on availability. Therefore, there can be no assumption that the same acquisition system is involved in all steps of a given procedure.

290 On the other hand, some protocols may involve several acquisition steps done at-once, back-to-back.

E.2.3 Reconstruction as a Separate Operation

NM differs from other modalities in the relationship between acquisition and reconstruction processes.

295 In most modalities the raw acquisition data has little clinical use. Reconstruction is generally performed on the modality and only the reconstructed images are exported from the modality.

For NM studies, the raw projection images are clinically useful images, and are often exported and viewed using the NM IOD.

300 When these projection images are tomographic (i.e., Image Type = TOMO or GATED TOMO) they can also be reconstructed into volume images similar to CT or MR images, i.e., a stack of slices. Although this reconstruction process can be done on the acquisition system as is done in most modalities, due to the availability of exported tomographic images, it may also be done on

other workstations depending on site preferences for particular vendors reconstruction algorithms, processing loads, and other workflow issues.

305 **E.2.4 Acquisition Post-Processing**

In addition to reconstruction, there are a number of other acquisition related processing steps performed on the acquired images. This includes:

- Uniformity Correction - to correct for non-uniformities in the detector hardware
- Decay Correction - to correct for radioactive decay of the injected tracer over time
- 310 • Scatter Correction - to remove photons scattered by tissue rather than emitted by the tracer
- Attenuation Correction - to compensate for photons absorbed within the body
- Patient Motion Correction - to compensate for patient motion during the scan
- Center of Rotation Correction - to compensate for offsets in the axis of rotation

315 Other possible corrections include deadtime, energy and linearity.

Some of these corrections, especially those that are hardware dependent or are specific to an acquisition system, must be performed on the acquisition modality if they are performed at all. To avoid encouraging potentially incomplete attempts to carry out these corrections away from the modality, the NM IOD intentionally leaves out attributes for attempting to convey all the relevant information.

320 Other steps, although generally performed on the acquisition modality, may, like reconstruction, be performed on a separate workstation depending on system capabilities and site preferences.

E.2.5 Clinical Post Processing

325 Finally, due to the metabolic/qualitative nature of NM imaging, it is very common to perform clinical processing on the images to extract quantitative details prior to final review.

These clinical processing packages too are sometimes available on the acquisition modality but may also be on a separate workstation. This processing includes things like:

- Re-orientation of volumes
- 2D and/or 3D segmentation (automatic and/or manual)
- 330 • Calculation of region characteristics
- Generation of time-plots
- Computation of functional images
- Generation of Result Screens

335 These activities are sometimes performed immediately following acquisition or may be left for batch processing at a later time.

E.2.6 Display and Reviewing

Unlike other modalities where the raw acquisition data has little clinical use, for NM images, the raw projection images are clinically useful images, and are often reviewed by the reading radiologist together with processed results.

340 Also, the color presentation of the images is common in Nuclear Medicine and is a clinical necessity for the interpretation of certain images.

E.2.7 Workflow Chaining

Due to the common use of processing workstations and clinical processing before reporting, the work on chained workflows being discussed in the IHE Radiology Technical Committee
345 whitepaper on Departmental Workflow will be of particular interest and relevance to Nuclear Medicine.

E.3 NM Worklists

The following informative text provides guidance on how NM activities would most logically be mapped to IHE Worklists and the concepts of Scheduled and Performed Procedure Steps.

350 The Scheduled Workflow Profile and Post-Processing Profile are very flexible in allowing complex procedures to be scheduled as a single procedure step (potentially with multiple procedure codes) or as multiple procedure steps. There are some situations which can work equally well with either approach, and ultimately sites will need to have some flexibility in how the work is scheduled in order to fit their work patterns.

355 That being said, the following are some basic guidelines which represent a sensible approach that should be considered. After the guidelines are a number of examples of how the guidelines would be applied to cases taken from typical clinical practice.

E.3.1 NM Worklist Guidelines

E.3.1.1 Injections

360 Scheduling, preparing, tracking and delivering the required dose of radio-pharmaceutical tracer is the job of the pharmacy and it does not make particular sense to include it in the worklists currently managed by the Radiology Profiles. It would make sense to address this in future Pharmacy and Enterprise Scheduling Profiles which would also handle related issues, such as
365 changing or canceling the order, managing drug interactions, QA and tracking of radioactive materials, etc.

The injection procedure step itself may also be scheduled and is frequently performed in proximity to the imaging equipment and in the presence of, or by, the modality operator.

As a practical matter, pending development of the above-mentioned profiles, it would be useful and not unreasonable for the DSS/Order Filler and the Acquisition Modality to allow injection
370 steps to be placed on the Modality Worklist, either as procedure codes in an acquisition procedure step or as an independent procedure step.

375 Further, the modality could allow the operator to indicate that the injection has been completed and generate corresponding MPPS details. Supporting codes for injections is not a requirement, but would be a useful feature. Note that the NM Image IOD already has attributes in the NM Isotope Module for modality systems that track injection details.

If the injection step is to be performed at the time of an acquisition, then it would be appropriate for the injection to be included as one Item in the Protocol Code Sequence within the Scheduled Procedure Step for the acquisition.

380 Injections that are performed outside of the acquisition room, some time prior to the data acquisition, are not particularly appropriate for inclusion in a modality worklist and are out of scope of this discussion.

385 While charges for radio-pharmaceuticals are generally built into the technical procedure fee, it would be appropriate and sometimes useful to include details about the radio-pharmaceutical dose in the Billing and Material Management Option described in RAD TF-2: 4.7. In cases where the MPPS indicates the procedure was cancelled, if an injection was still performed, it would be appropriate to include that information in the MPPS.

E.3.1.2 Acquisitions

It is suggested that, in general, each acquisition of image data be scheduled as a separate procedure step.

390 Clinical protocols that include having the patient leave the acquisition system between acquisition steps, must schedule them as separate Scheduled Procedure Steps. However, when several acquisition steps are done at-once, back-to-back, they can either be scheduled as multiple Scheduled Procedure Steps, or as a single Scheduled Procedure Step with multiple protocol codes. Scheduling using multiple Scheduled Procedure Steps allows the greatest flexibility in use
395 of available equipment and the greatest detail in status reporting. Of course, the acquisitions will still likely be part of the same Study with the same Study UID.

Note that support of multiple Scheduled Procedure Steps resulting from a single Requested Procedure is already required in the Scheduled Workflow Profile, but support of multiple protocol codes is optional. Support for multiple performed protocol codes in the Performed
400 Procedure Step is recommended.

405 An issue worth mentioning is that due to studies involving multiple acquisitions, several acquisition modality systems may participate in the same study. While the Study Instance UID is obtained from the Worklist by both modalities and will be correctly included, the rest of the Study level information, such as study date/time, study description, etc., is generally not provided in the Worklist. This means that each modality will generate their own values and include them in the generated images, resulting in Series instances in the same Study which have different Study level information (except the UID). It is assumed that the Image Manager/Archive will manage any issues related to this.

E.3.1.3 Reconstruction

410 It is recommended that the reconstruction of acquired (tomographic) image data be treated as a separate Performed Procedure Step. That is, the acquisition system should issue a Performed Procedure Step Complete message when the tomographic acquisition is complete.

Then, whatever system performs the reconstruction of this data, whether it is the original acquisition system, or some other system, should issue a new Performed Procedure Step for the reconstruction process, related to the same Scheduled Procedure Step. In this way, scheduling of tomographic acquisitions is consistent with other modalities like CT, but allows the reconstruction to be performed flexibly by any system.

415 These Reconstruction steps, and other post-processing, may be carried out as explicit workflow by placing them on worklists as outlined in the Post-Processing Workflow Profile, or may be carried out as implicit workflow by the operator knowing these steps should follow acquisition as outlined in the Scheduled Workflow Profile.

E.3.1.4 Acquisition Post-Processing

Due to the nature of Acquisition Post-Processing, as described in Section E.2.4, it will almost always be performed on the acquisition system or on a workstation bundled with the acquisition system. While it is conceivable that some batch-oriented site workflows could benefit from doing these steps with an explicit worklist, the vast majority of sites will do these steps as implicit workflow. Further, the acquisition post-processing steps are seldom billable and there is little need for detailed tracking of these steps.

425 If the processing is performed on a separate workstation the steps should be considered as separate procedure steps but there is likely only a need to create Performed Procedure Step messages when the step creates new images which will be sent to the Image Manager/Archive.

430 If the processing is performed on the acquisition modality system, which is the most likely, it is acceptable to include the steps as additional protocol codes.

E.3.1.5 Clinical Post-Processing

435 Clinical Post-Processing, as described in Section E.2.5, may be done at some sites using explicit workflow, although many sites will handle it with implicit workflow.

If the processing is performed on a separate workstation the steps should be handled as separate procedure steps, either scheduled as explicit workflow as described in the Post-Processing Workflow Profile or unscheduled as implicit workflow as described in the Scheduled Workflow Profile.

440 If the processing is performed on the acquisition modality system it is acceptable to include the steps as additional protocol codes, however it is recommended to handle them as separate procedure steps.

E.3.2 NM Worklist Examples

445 The following are some examples of clinical situations and an example of an appropriate way to handle them based on the above guidelines.

E.3.2.1 Injection and immediate imaging

Example: Renal scan (Dynamic)

The patient is injected under the camera, and imaging is started immediately.

450 Use a single SPS which includes protocol codes for the injection and for a single acquisition.

E.3.2.2 Injection and delayed imaging

Example: Bone scan to assess for malignancy (Static or Whole body)

The patient is injected somewhere (could be in the imaging department or at the patient bedside), and images are obtained several hours later.

455 Use a single SPS which includes a single acquisition. The injection details are handled out of scope.

E.3.2.3 Injection with both immediate and delayed imaging

Example: 3-phase bone scan for infection (Dynamic and Static)

460 The patient is injected under the camera, and imaging is started immediately. More images are obtained several hours later, on the same or a different gamma camera.

Use two SPS. The first SPS includes protocol codes for both the injection and the initial dynamic and static acquisitions. The second SPS is for the second static acquisition. Images acquired from the second SPS must be in a different Series from those from the first SPS.

E.3.2.4 Injection and immediate imaging, with possible further imaging

465 Example: Renal scan to evaluate for obstruction, with possible second diuretic acquisition (Dynamic)

The patient is injected under the camera, and imaging is started immediately. The results will determine whether more imaging is needed.

470 Schedule two SPS as in Section E.3.2.3. The images from the first SPS can be read, and then a determination can be made as to whether or not the second acquisition is required. If it is not needed, then the second SPS can be cancelled at the modality by issuing an MPPS aborted message.

E.3.2.5 Injection and very delayed imaging

Example: I-131 whole body imaging (Whole body)

475 The patient dose is given, and images obtained days later.

Optionally schedule one SPS for the injection if it is performed in the imaging suite. An SPS would be scheduled for the acquisition.

E.3.2.6 Imaging and no injection

480 Example: Add-on imaging after therapeutic administration by radiation oncology (Static or Whole body)

The patient dose is given by someone else in the radiation oncology department for the purpose of therapy. Several days later, imaging is performed for evaluation purposes.

A single SPS is used for the image acquisition.

E.3.2.7 Two isotope examination, with two imaging times

485 Example: Dual isotope [Thallium-201 “rest” images & Tc-99m Sestamibi “stress” images] myocardial perfusion study (Gated Tomo)

The first isotope is injected followed by image acquisition. A second isotope (possibly under different patient conditions) is subsequently injected followed by a second image acquisition (possibly on a different camera).

490 This protocol uses two SPS. The first contains protocol codes for the first injection and the first acquisition. The second SPS contains protocol codes for the second injection and acquisition. Each of these two acquisitions constitutes a separate Series.

495 It should be noted that these are simply suggestions of one approach that makes sense. Sites will of course be interested in scheduling in ways that make sense to them. It is conceivable that an ECG or Treadmill might implement Modality Worklist, allowing their activities to be scheduled and monitored steps, however such actors do not currently exist in the framework and such implementations are currently unlikely.

E.3.2.8 Two isotope examination, with single imaging time

500 Example: Dual isotope [In-111 labeled White blood cell “infection” images & Tc-99 sulfur colloid “bone marrow” images] infection study (Dual Energy Static or Whole body)

In this example the first isotope is injected on day one. Then the following day the second isotope is injected 30 minutes before the acquisition step which images both isotopes.

Consider three SPS. The first SPS (optional) for the first injection, the second SPS for the second injection, and the third SPS for the actual acquisition.

505 Note that this case might result in billing for two exams (White Blood Cell study and Bone Marrow imaging), but most centers would actually only issue a single report, since there was only one imaging step. This is sort of like the case where an abdomen and pelvis CT was done as a single acquisition, and then read by the same person, but billed as two "studies" (i.e., the PGP Profile).

510 **E.3.2.9 Acquisition and Reconstruction on the Acquisition Modality**

Example: Cardiac Tomographic acquisition followed by basic corrections, reconstruction and re-orientation to align the volume with the cardiac Short Axis.

515 A single SPS is created which calls for one cardiac tomographic acquisition. The modality performs the acquisition and sends an MPPS Complete message, referencing the created tomographic images.

The modality then does corrections and reconstruction of the tomographic data, appends a new MPPS and reports it complete, without referencing the intermediate image data.

520 Finally, the reconstructed data is re-oriented into cardiac Short Axis images and the modality appends a third MPPS to report the reformatting processing, and referencing the re-oriented slices.

The initial tomographic images and the final re-oriented slices are stored to the Image Manager/Archive.

525 This example raises a point that is sometimes overlooked. MPPS transactions should only include references to series/images which will be (or have been) sent to the Image Manager/Archive. The implication of including the references is that they will be sent to the Image Manager/Archive. Correspondingly, the Image Manager/Archive will be waiting for all referenced images and may continue to consider the study incomplete until they arrive. Thus, referencing images which will not be sent can have the effect of derailing the workflow.

E.3.2.10 Re-orientation on an Evidence Creator with Implicit Workflow

530 Example: Same as the previous case, but all of the processing takes place on a separate Evidence Creator based on implicit workflow as described in Scheduled Workflow.

A single SPS is created which calls for one cardiac tomographic acquisition. The modality performs the acquisition and sends an MPPS Complete message.

535 The modality then does corrections and reconstruction of the tomographic data, appends a new MPPS and reports it complete.

The initial tomographic images are stored to the Image Manager/Archive and the reconstructed slices are stored to the Evidence Creator workstation.

540 The workstation re-orientes the reconstructed data into cardiac Short Axis images and sends a new MPPS to the PPS Manager. The SPS and patient references in the created images and MPPS are copied from the information in the received slice images.

The Evidence Creator stores the final re-oriented slices to the Image Manager/Archive.

E.3.2.11 Re-orientation and Post-Processing on an Evidence Creator with Explicit Workflow

545 Example: Same as the previous case, but the work is placed on a Post-Processing Worklist and the Evidence Creator also performs post-processing that produces some Result Screens.

A single SPS is created on the Post-Processing Worklist with codes for Re-orientation and Clinical Result Processing.

550 When the task is selected and the inputs are available on the Evidence Creator, the re-orientation is performed followed by Clinical Result Processing. The Evidence Creator sends an MPPS Complete for the two codes.

The re-oriented slice images and result screens are stored to the Image Manager/Archive.

The timing of placing the SPS on the Post-Processing Worklist is not discussed here as that is the topic of an IHE Radiology Technical Committee whitepaper on Departmental Workflow and is still under discussion.

555 In the above two cases, data was considered to be pushed from the Acquisition Modality to the Evidence Creator. This is a typical practice, but it should be noted that the mechanism for this is not specified by IHE. The processing system may retrieve the images from the acquisition modality, the acquisition modality may push them to the processing system, or the Image Manager/Archive could be used as a common storage and retrieval point.

560 Also, applications that perform clinical post-processing often need to identify specific related series to use as inputs for processing (for example the corresponding stress and rest series for a cardiac study). The software should look to the DICOM fields to determine the patient state and type of Image. The information in the fields may be utilized automatically by the software or may be presented to the user for manual selection.

565 **E.4 NM Data**

The NM Image IOD (refer to DICOM [PS3.3 Section C.8.4.9](#)) supports several NM Image Types as indicated by the code contained in Value 3 of the Image Type (0008,0008) attribute.

The currently allowed Image Types are:

570 STATIC - Simple projection image containing one or more frames (e.g., individual views of the lungs).

WHOLE BODY - Projection image where each frame spans the length of the body (e.g., an anterior and/or posterior view of the body).

DYNAMIC - Projection image containing a series of frames typically showing the same anatomy over time (e.g., a view of renal isotope uptake and washout).

575 GATED - Similar to DYNAMIC, except the frames are composed to span phases of a gated interval (e.g., a beating view of the heart).

TOMO - Projection image with frames take from various angles as the detector rotates about the patient. Generally used to reconstruct volume slices.

580 RECON TOMO - Reconstructed image with frames corresponding to cross-sectional slices covering a volume. Created by reconstructing TOMO image frames.

GATED TOMO - Similar to TOMO, except each angle has multiple frames representing the phases over a gated interval. Generally used to reconstruct gated volume slices.

585 RECON GATED TOMO - Reconstructed image with frames corresponding to cross-sectional slices covering a volume at each phase of a gated interval (e.g., a beating heart volume, created by reconstructing GATED TOMO image frames).

590 In the NM IOD the information about the orientation and position of the acquired image (frame) is placed in the description of the acquiring detector. So, if the same physical detector acquires data at several locations, there will be separate detector description for each position. Because of this, the detector description in the NM IOD is that of a logical detector. Most NM acquisition modalities have 1, 2, or maybe 3 physical detectors. But an NM object created by these modalities may contain considerably more logical detectors in cases where the acquisition system is moved or rotated about the patient.

E.4.1 Study UIDs and Series UIDs

595 The basic guidelines for creating Study, Series and SOP UIDs are provided in RAD TF-2: 4.8.4.1.1.1.

While the decision as to what constitutes a new Series is traditionally left to the modality, it can be said that a series contains images that represent the output of a single procedure step on a single piece of equipment with a single patient positioning. In practice, the series has frequently been used to collect a group of single-frame IODs such as the CT slices making up a volume.

600 In multi-frame IODs such as NM, this is not necessary, as related frames are generally already grouped together in the multi-frame IOD. Therefore, it is strongly recommended that each separate acquisition should become a new Series.

605 Stress and rest cardiac exams separated by a time delay, potentially of hours, should be separate Series since they may be scheduled separately, could be performed on different acquisition systems, and may not be able to position the patient identically.

Similarly, reconstruction or post-processing steps must be different Series if they are done on different workstations. For consistency, it is required here that they always be placed in different Series.

610 It is also recommended that when new results are produced by doing the same processing on the same data (for example, to reprocess with slightly different parameters), then each repetition of the processing step should result in images that are part of a new Series.

Processing functions that produce multiple Images from a single processing step (for example, several static SC Images, multiple reconstructed views, etc.) should use the same Series for all of the Images.

615 It is recommended that object creators fill the Series Description attribute with a value that would indicate to users the nature of the contents of the object. In particular the value should help in differentiating Series in the same Study. The Series Description is reasonably well supported by PACS systems, while image level fields are less widely supported.

E.4.2 NM Image IOD: Multi-Frames and Vectors

620 It is important to understand that although single-frame DICOM images are most common in current use in other modalities, the DICOM Nuclear Medicine Image IOD is a multi-frame image. This means typically an Image will contain multiple 2-D pixel arrays called Frames. Refer to DICOM [PS3.3 Section C.8.4.8](#) for details.

625 The object becomes more complex due to the fact that each frame is indexed according to a number of acquisition “dimensions” such as Energy Window, Detector, Angle and Phase. Each frame is indexed in each dimension by a “Frame Pointer” vector.

An example of the Frame Increment Pointer vectors for a Dynamic Image is shown here (taken from DICOM [PS3.3 Section C.8.4.8](#)):

The Pixel Data (7FE0,0010) would contain the frames in the following order:

630

Frame	1	2	3	4	5	6	7	8	9	10	11	12	13	14
Energy Window #	1	1	1	1	1	1	1	1	1	1	1	1	1	1
Detector #	1	1	1	1	1	1	1	2	2	2	2	2	2	2
Phase #	1	1	1	1	1	2	2	1	1	1	1	1	2	2
Time Slice #	1	2	3	4	5	1	2	1	2	3	4	5	1	2

and the four vectors would be defined as:

Energy Window Vector = 1,1,1,1,1,1,1,1,1,1,1,1,1,1,1

Detector Vector = 1,1,1,1,1,1,1,2,2,2,2,2,2,2,2

Phase Vector = 1,1,1,1,1,2,2,1,1,1,1,1,2,2

635

Time Slice Vector = 1,2,3,4,5,1,2,1,2,3,4,5,1,2

Each vector attribute has a matching “Number Of” attribute indicating how many values are enumerated in the corresponding vector. In the above example the Number of Energy Windows = 1 indicating that only one energy window was used so all the entries in the Energy Window Vector will contain the same value.

640 For each NM Image Type, the DICOM standard specifies the frame increment pointers which must be present and the order in which the pointer vectors are stored. Typically, the last vector will vary most rapidly, although exceptions exist. The NM Image Type is stored in Value 3 of the Image Type attribute (0008,0008).

E.4.3 Typical NM Data Dimensions

645 Typical sizes of NM Image frames and NM Image vectors are provided in the following table.

Table E.4-1: NM Image Characteristics

Image Type	Typical Matrix Size	Frame Increment Pointer [i.e., vectors]	Typical #
STATIC	128 x 128 256 x 256	Energy Window (0054,0010)	1 - 2
		Detector (0054,0020)	1 - 2*
		[Total Frames]	1 - 12*
WHOLE BODY	1024 x 256 1024 x 512	Energy Window (0054,0010)	1 - 2
		Detector (0054,0020)	1 - 2
		[Total Frames]	1 - 4
DYNAMIC	64 x 64 128 x 128	Energy Window (0054,0010)	1 - 2
		Detector (0054,0020)	1 - 2
		Phase (0054,0100)	1 - 3
		Time Slice (0054,0030)	1 - 120
		[Total Frames]	1 - 1440
GATED	64 x 64 128 x 128	Energy Window (0054,0010)	1
		Detector (0054,0020)	1
		R-R Interval (0054,0060)	1
		Time Slot (0054,0070)	8 - 32
		[Total Frames]	8 - 32
TOMO	64 x 64 128 x 128	Energy Window (0054,0010)	1
		Detector (0054,0020)	1
		Rotation (0054,0050)	1
		Angular View (0054,0090)	30 - 128
		[Total Frames]	30 - 128
GATED TOMO	64 x 64 128 x 128	Energy Window (0054,0010)	1
		Detector (0054,0020)	1
		Rotation (0054,0050)	1
		R-R Interval (0054,0060)	1
		Time Slot (0054,0070)	8 - 16
		Angular View (0054,0090)	30 - 128
		[Total Frames]	240 - 2048
RECON TOMO	64 x 64 128 x 128	Slice (0054,0080)	12 - 128
GATED RECON TOMO	64 x 64 128 x 128	R-R Interval (0054,0060)	1
		Time Slot (0054,0070)	8 - 16
		Slice (0054,0080)	12 - 24
		[Total Frames]	96 - 384

* Note that although the number of physical detectors is generally 1 or 2, the object may potentially contain a separate logical detector for each frame in the image as described in the last paragraph of Section E.4 above.

650 **E.5 NM Display**

E.5.1 NM Intensity and Color Mapping

The control of display intensities in Nuclear Medicine is different than that used for CT or MR images due to inherent differences in the modality imaging process and the resulting image characteristics.

655 In CT images are characterized by the fact that the pixel values represent Hounsfield units. Bone is represented by a well-known value plus or minus a typical range. Soft tissues are represented by another well-known value plus or minus a range. In this space it makes sense to provide controls for selecting a Window Center and a Window Width.

660 In NM images, the pixel values typically represent radioactivity “counts”. Due to differences in radiopharmaceutical type, dose, time between injection and imaging, length of scan, overlying tissue density, metabolic processes and many other things, the pixel values cannot be considered strictly quantitative. Further, the image is often characterized by very high intensity “hot spots” where a very high concentration of tracer may have accumulated; and by a low level of background activity (“noise”) from non-specific uptake and scatter. For such images, it is
665 appropriate to provide a control that would allow setting a threshold level to cut out the low level background, and another threshold to cut off the high level hot spots which might otherwise obscure mid-range intensities.

Control of NM display intensities is therefore based on Upper and Lower Window Levels. These are different than Window Width and Center but the two are readily interchangeable by a simple
670 linear mathematical transform.

$$\text{Window Upper} = \text{Window Center} + \frac{1}{2} \text{Window Width}$$

$$\text{Window Lower} = \text{Window Center} - \frac{1}{2} \text{Window Width}$$

Or conversely,

$$\text{Window Width} = \text{Window Upper} - \text{Window Lower}$$

675 $\text{Window Center} = (\text{Window Upper} + \text{Window Lower}) / 2$

NM pixel values can generally be represented in 16 bits of data. The Window Upper and Lower Levels indicate the current range of pixel values of interest. It is recommended that the upper and lower window values be displayed in the interface.

680 Some NM datasets may contain very high pixel values. To display the images, it is generally necessary to map the NM Image pixel values into the range of grey levels which can be displayed by the hardware (most displays have much fewer discernible grey levels than there are pixel values in the dataset).

685 Generally, the display should be able to map pixel values to at least 128 display intensity levels. If the display supports more display intensity levels, the ability to map to more levels is preferred, if the display is only capable of fewer display intensity levels, it is acceptable to map to fewer levels. Mapping to 64 display intensity levels is also acceptable if it is necessary to display multiple color scales (see below) at the same time.

690 If the mapping is done only once when the image is first loaded then the presence of a small number of very high pixel values will result in most of the available display levels being “wasted” on a small number of pixels, leaving very little contrast in the rest of the image.

To make effective use of the available display intensity contrast, it is useful to do rescaling after each Window Level adjustment, or to provide a way to control the maximum pixel value used for mapping. A similar problem (and solution) occurs when switching between examining bone and soft tissue windows in a CT image.

695 If presentation state information is available with the images, it is generally preferred to use it for the initial display. Note that the Window Center and Window Width attributes in the presentation state object will also map to Upper and Lower Window values as described above.

700 In the absence of presentation state information, it would make sense to display the framesets initially with the Upper and Lower Window Levels set based on the algorithm above and the values stored in the Window Center (0028,1050) and Window Width (0028,1051) attributes of the image data.

In the absence of Window Center and Width values, a possibly viable setting may be the Lower Window level set to zero and the Upper Window Level set to the maximum pixel value of the frameset.

705 Typical Nuclear Medicine clinical practice also differs from CT and MR in the prevalence of applying pseudo-color lookup tables or “color-scales” to the grayscale data during review. This is done to enhance particular features of the data in certain ways.

710 Different sites, and sometimes different radiologists within each site, will generally have strong preferences about which color-scales they use for various pathologies in various types of NM studies. It is not unusual for NM review stations to have dozens of color-scales available.

The ability for users to edit and/or create new pseudo-color lookup tables on the Image Display is occasionally useful but not required. Far more useful is the ability to install a preferred collection of color-scales on the system. The Society of Nuclear Medicine (SNM) has plans to act as a repository for a collection of common and popular color-scales.

715 Since exported Result Screens in NM almost always contain image data, many users will want to be able to apply a pseudo-color lookup table and the ability to adjust Upper and Lower Window Levels of monochrome Secondary Capture and Multi-Frame Secondary Capture Images which have a modality type of NM. It may be unavoidable and would generally be acceptable that this could change the display values for any included graphics and annotations.

720 **E.5.2 NM Image Resizing**

725 NM Images typically range in size from 64x64 to 512x1024 with the majority of the frames at the smaller end of the spectrum. Such small images must be enlarged on the display to be clinically useful, adding unnecessary steps to the reading radiologists’ workflow. A common mistake of general-purpose display systems is to initially display these 64x64 frames at “full resolution” which results in a screen of “postage stamps”.

Correspondingly, Whole body Image frames should generally not be scaled down for initial display, unless such scaling is needed to fit the whole body frame onto the screen.

The following table provides some guidelines on appropriate default zoom factors for various frame sizes. These are intended to simply provide a starting point for systems without sophisticated layout algorithms.

730

Table E.5-1: Frame Zoom Guidelines

Actual Frame Size	Default Display Size	Default Cine Size
32x32 to 63x63	Display at 4x	Cine at 4x
64x64 to 100x100	Display at 3x if 12 or fewer frames Display at 2x if greater than 12 frames	Cine at 4x
101x101 to 200x200	Display at 2x if 12 or fewer frames Display at 1x if greater than 12 frames	Cine at 3x
201x201 to size of display area	Display at 1x	Cine at 2x (if display area permits) Cine at 1x otherwise
Greater than display area	Shrink to fit in display area	Shrink to fit in display area

Note that while NM images are generally square, they are not required to be so, and it would be appropriate to use just the larger of the x and y dimensions when deciding the zoom factor.

735 Obviously, there is interplay between the number of frames to display, frame size, zoom factor, and display layout. For example, increasing the zoom from 2X to 3X will result in fewer rows and columns of frames available for display at a given time. Image Displays are encouraged to make intelligent use of display space. Note that horizontal scrolling is preferable to scrolling both vertically and horizontally.

740 With the above table as a starting point, most users will want to have a way of selecting the display size for the frames. A simple selection of 2X, 3X or 4X zoom may be sufficient. Alternatively, selecting a display format (such as 2x2, 8x8, 4x1, etc.) is also acceptable, though a much wider range of such formats may be needed for NM images than for other modalities, given the small NM image size. Some systems have an option for image magnification, where
745 the size of the displayed area on the screen remains unchanged, but as magnification is increased, less and less of the image is shown, but the portion that is shown is displayed in greater detail. For example, on a femur bone x-ray, one might magnify a portion of the screen to just see the hip portion of the femoral bone, in order to see it at greater resolution. Such magnification is rarely used in nuclear medicine, with the possible exception of the Whole Body images. Such Whole
750 Body images are typically 1024 pixels in height, and may not fit on the screen if a larger zoom is employed. In such cases, it may be necessary to magnify the contents of the frame instead, and

allow the user to designate in some manner the portion of the frame he wants to center on as the magnification is increased.

E.5.3 NM Display Examples

755 **E.5.3.1 Example Layouts**

The following are example layouts illustrating the different Display Formats identified in RAD TF-2: 4.16.4.2.2.3.2. These are only intended as illustrative examples.

Grid Display

A ₁	A ₂	A ₃	A ₄	A ₅	A ₆	A ₇	A ₈
A ₉
...
...	A ₃₂ ...

760

Comparison Display (2 Framesets)

A ₁	A ₂	A ₃	A ₄	A ₅	A ₆	A ₇	A ₈
B ₁	B ₂	B ₃	B ₄	B ₅	B ₆	B ₇	B ₈

or alternatively,

A ₁	A ₂	A ₃	A ₄	A ₅	A ₆	A ₇	A ₈
A ₉	A ₁₆

B ₁	B ₂	B ₃	B ₄	B ₅	B ₆	B ₇	B ₈
B ₉	B ₁₆

765

Whole body Display (2 Framesets, 2 Frames each)

A ₁	A ₂	B ₁	B ₂
----------------	----------------	----------------	----------------

Fit Display (3 images, from 3 series with two frames each)

770

A ₁	A ₂	B ₁	B ₂
C ₁	C ₁		

MPR Display (one transaxial volume, with a supplied or generated MIP cine display)

Transaxial	Sagittal
Coronal	MIP (cine)

775

Note that the MIP is not strictly part of the MPR display, but since it is frequently useful, some vendors provide it.

or alternatively,

Coronal y - 1	Coronal y	Coronal y + 1
Axial z - 1	Axial z	Axial z + 1
Sagittal n - 1	Sagittal n	Sagittal n + 1

780

Cine Display (three images from 3 series, each cycling synchronously)

A ₁₋₃₂	B ₁₋₃₂	C ₁₋₃₂
-------------------	-------------------	-------------------

E.5.3.2 Clinical Examples

This section provides examples and clarifications on typical patterns of display for NM Images.

785 This section should not be considered as an attempt to address hanging protocols. This is a complex topic which DICOM is working on. Once that work is complete, NM and Radiology in general would benefit from that work being included in the IHE Framework. This section is not intended to supplant that.

790 See RAD TF-2: 4.16.4.2.2.3 for a description of some of the display related capabilities referred to in these examples.

Example 1: Cardiac Study

The user selects a Tomo stress series, several static result screens (secondary captures), another Tomo rest series, and a dynamic result screen (multi-frame secondary capture).

795 The user would like to see both Tomo images together in a Row Display and be able to view them synchronously in Cine display, preferably with a method for adjusting the cine speed.

Next the user would like to step forward and backward through each of the secondary capture result screens (which may be stored in a set of Secondary Capture images or in a single Multi-Frame Secondary Capture image without a cine module).

800 The user would also like to review the dynamic result screen in cine mode. It is useful to be able to adjust the cine speed. Systems unable to cine the result screen at 8 frames/sec or faster would have limited clinical usefulness.

Example 2: Lung Perfusion Study

The user selects 4 Static series containing a total of 8 frames. The user would like to see all 8 frames in a Fit Display (preferably with the frames resized to 256x256)

805 **Example 3: Ventilation-Perfusion Study**

The user selects the (several) series corresponding to lung perfusion imaging, and the (several) series corresponding to a lung ventilation imaging. The user expects to be able to review the ventilation and perfusion frames together in a Fit Display. The user may wish to adjust each series' intensities and the zoom factor.

810 It may be useful to select several series and adjust the intensities together.

Example 4: Gastro-intestinal Bleed Study

815 The user selects 2 dynamic images containing anterior and posterior frames from a two-phase 90 minute gastro-intestinal bleeding exam, with a grand total of 300 frames. The user expects to be able to page through the frames (showing them all at once would make the frames too small) in a Grid Display.

The user would also expect to select one or other view, or one of the phases and view the frameset in a Grid Display.

Finally, the user would view a cine (perhaps two cines, one anterior frameset and one posterior frameset, or a single cine that allows the user to cine one view or the other independently).

820 Example 5: Renal Study

The user selects a dynamic study. The user expects to see a Grid Display to page through the frames and to be able to cine the time vector.

825 When more than one phase is present, it is useful to be able to control the upper and lower levels of the phases separately. A user may wish to select a frame set corresponding to the first phase of a Dynamic Image, which represents the flow portion of the exam, and lower the Upper Window Level to increase the visibility of these “low-count” frames. The second phase frame set, which contains images which are inherently much brighter, should be left unadjusted.

In general, typical display formats for each of the NM Image Types would be as follows:

830 **STATIC:** Simple display. Typically, several images displayed at once (for example in a Fit display). While the default order of frames in the object is sorted by Energy Window then Detector, it is generally more useful to present them in Detector/Energy Window order or sorted by acquisition time. Example: 12 view static

WHOLE BODY: Side by side display of two rectangular images (i.e., the Whole Body display).

835 **DYNAMIC:** Cine through all frames of all phases from one detector and one energy window, in order. It is also useful to display in a Grid or Row display. Generally, a different window level applies to each phase. Processing (not required by the NM Profile) includes plotting time activity through user selected areas of the image.

840 **GATED:** Cine through the frames from one detector/energy window, in time order. Processing (not required by the NM Profile) can include time activity curves, heart wall edge detection and motion tracking, etc. Typically, several images displayed at once.

TOMO: Cine all frames from one (logical) detector in rotational angle order. Recommend ability to cine back and forth (i.e., frames 1 to n, followed by frames n to 1), in addition to the standard forward cine.

845 **RECON TOMO:** Display all slices in spatial order. Typical display actions can include reorientation to other viewing planes (MPR). Processing (not required by the NM Profile) can include oblique reorientation to cardiac relative views, creation of MIP images, etc. Example: Stress-Rest in a Row Layout display, or a single dataset in an MPR Display.

850 **GATED TOMO:** Cine all frames (angular views) from one energy window, one (logical) detector, one rotation, one R-R interval, and one Time Slot, or all Time Slots from one energy window, detector, rotation, R-R interval, and Angular View. Some users do not review these images unless data acquisition problems are suspected.

GATED RECON TOMO: Cine all frames from one R-R Interval and one Time Slot. Typical processing includes all functions done to RECON TOMO images, plus special cardiac processing such as bull’s-eye plot creation.

855 Examples of simultaneous cine: three TOMO images (used for quality control of cardiac raw projections); three GATED planar exams (RVGs); or 2 detectors from a dynamic image.

Note that in the U.S., ACR accreditation requires the ability to label displayed images with the patient name, patient age (or date of birth), patient identification number, date of exam, institution name, and some means of identifying the technologist who performed the study.

860 The Nuclear Medicine Accreditation Committee of the ACR has further required that laterality and orientation information also be provided.

Appendix F: Security Environment Considerations

IHE compliant systems usually process private healthcare information. This is subject to national privacy regulations, and possibly other state and contractual requirements. The IHE profiles do not fully define the security mechanisms necessary to protect this information. The ITI Audit Trail and Node Authentication (ATNA) Profile ([ITI TF-1: 9](#)) provides one component of this solution.

IHE assumes that actors will be installed on nodes with the following characteristics:

- 870 • Each node has a security policy and procedure that applies to its operation.
This is assumed to be part of the healthcare enterprise security policy.
- Any user (human, or application process) external to the node boundaries is submitted to an access control procedure in which the user/application will be authenticated.
- All required audit trail events are captured and recorded.

The profiles in this framework assume the following environment:

- 875 • Physical Security Environment
 - 880 o The equipment is assumed to be located in a physically protected and actively monitored area. This is normally the case with modality equipment because of other patient safety, privacy, and operational concerns. Similarly, the HIS systems and various archives are normally protected. Equipment like PACS workstations are sometimes placed in unprotected areas, but it is usually located where hospital staff monitors and limit access. It assumes that the threat of equipment modification is protected against by means of the physical security mechanisms.
 - 885 o The network equipment that connects the computers is also assumed to be physically protected against unauthorized connections and unauthorized modifications. In the treatment areas of most hospitals the network equipment is in ceilings, cableways, locked cabinets, and other protected areas. There is usually staff present to monitor that no unauthorized activity is taking place.
 - 890 o Local procedures and operations will be in place to ensure that the physical security assumptions are valid for other areas of the hospital, such as administrative offices, that may be at greater risk.

- 895
 - o Remote locations, especially home offices, are not physically protected. Other means will be used to provide equivalent protection. This may include the use of technology such as VPN connections or HTTPS encryption. Use of encryption or VPN is not a complete replacement for physical security but may be part of an overall protection system.
 - o The home computer that is used for both personal and professional purposes is difficult to protect. It will be protected from inadvertent modification by malicious software or its use will be prohibited.
- Network Security Environment
- 900
 - o In addition to the physical security of the network, there will be protection against network access by unsupervised systems. This is typically provided by mechanisms such as firewalls and VPNs.

The threat profile is assumed to be:

- Accidental and inadvertent misuse
- 905
 - Individual abuse for personal gain, malice, revenge, or curiosity. The abusers are assumed to have only limited access to the underlying systems and software. They are not expert at the internal structure of the systems.
 - Random untargeted abuse, such as from an Internet hacker.

910 The threat profile also assumes that the following threats are either not present or otherwise protected.

- Individual abuse by a system administrator, system developer, or other expert.
- Military or hostile government action
- Organized criminal attack

915 IHE addresses only those security requirements related to IT systems within the scope of IHE healthcare applications. It does not address security requirements for defending against network attacks, virus infection, etc.

920 IHE does not mandate the use of encryption because the performance impact of current encryption algorithms is excessive. Most hospital networks provide adequate security through physical and procedural mechanisms. The additional performance penalty for encryption is not justified for these networks. The profiles permit the use of encryption so that it can be used as part of an overall security plan.

Appendix G: Patient Information Reconciliation for XDS-I.b (INFORMATIVE)

925 Patient Information Reconciliation (PIR) workflow within a local domain is well understood and addressed within the IHE PIR and Scheduled Workflow.b Profiles. However, within an XDS affinity domain, there is the added complexity of managing patient information within the XDS Document Registry and synchronizing data between the document sources, repository and registry.

930 The ITI XAD-PID Change Management (XPID) Profile ([ITI TF-1: 31](#)) addresses patient ID challenges in the context of an XDS environment. It allows a PIX Manager to notify an XDS Document Registry of external changes to XDS Affinity Domain Patient IDs (referred to as XAD-PIDs) so that it can affect these changes, as appropriate, in its database.

935 This Appendix is considered informative and serves to demonstrate that imaging information content does not introduce any new or imaging information content specific PIR issues.

G.1 Context and Assumptions

G.1.1 XDS Affinity Domain Assumptions

- The Document Registry assumes that all documents have a normalized patient ID pertaining to the XDS Affinity Domain. Therefore:
 - 940 o The XDS Affinity Domain must have a Patient Identification Domain in order to realize normalized patient IDs.
 - o The XDS Affinity Domain must have a Patient Identity Source
 - o To simplify description in this section, the nomenclature for the XDS Affinity Domain will be “XAD”.
- 945 • A Document Source is responsible for obtaining the XAD patient ID for registering the document within the registry. The XAD patient ID that is obtained is only used for this purpose and is not used to update any patient ID’s within the document. Patient ID’s within the document shall remain unchanged by the registration process
- A Document Consumer is expected to query the Document Registry using the XAD patient ID
- 950 • The Registry can only accept a document if the document has a valid XAD patient ID
- The Registry must check to see if the XAD patient ID is valid. This can be done in two ways:
 - 955 o Query the XAD Patient Identity Source to see if the XAD patient ID exists – not supported at this time
 - o Maintain all XAD patient IDs in the registry irrespective of whether there are documents for that patient i.e., keep in synch with the XAD Patient Identity Source – this is the expected model

- The Registry cannot accept a document with an OID that is already registered
- 960 o If a document is submitted that has the OID of a document already registered, the Registry will reject the submission
- o If a document is re-submitted and, thereby, is identical to a document already submitted, the Registry will reject the submission

G.1.2 Metadata in the Document Registry

- 965 • The XAD patient ID is the only piece of metadata that can be reliably used to query for a patient
- The Registry maintains supporting patient information such as Name, Sex, DoB, etc. but is NOT obligated to ensure the referential integrity of this data. Therefore:
 - 970 o This information is NOT used for query matching (but is only used for audits and potential verification of Document Consumers)
 - o There is no requirement for the XDS Document Registry to verify that the meta-data in the Registry corresponds to the patient information in the document itself
- The Registry does track the local domain source patient ID, but this is not used for query matching

G.1.3 Patient Identity Management in the XDS Registry

- 975 • The Registry keeps a list of known XAD patient IDs
- The Registry associates documents with the patient IDs
- The Registry receives patient “merge” notifications from the XAD Patient Identity Source
- 980 • The Registry is responsible for updating XAD patient IDs associated with documents
- The Registry does not update metadata nor document content
- If the clinical content of a document has changed, the Document Source is responsible for updating the Document Repository and Document Registry

G.1.4 Expected Implementation Models for Patient Identity Management

- 985 In a cross-enterprise scenario, we assume that there are multiple patient identity domains
- Local patient identity domains that support one or more enterprises. These pertain to Document Sources and Document Consumers
 - Affinity Domain patient identity domain

990 Each patient identity domain has a Patient Identity Source. In the case of local domains, this is likely to be an ADT system. For the Affinity Domain, this is yet another patient registry.

A participating enterprise may deploy a Patient Identifier Cross-Referencing (PIX) Manager to cross-map Patient ID in the local domain to Patient ID in XAD domain. In such cases, the PIX Manager will interact with the Affinity Domain Patient Identity Source.

995 Document sources and consumers are required to obtain a normalized XAD patient ID. The mechanism for achieving this is dependent on the implementation of patient identity feeds and patient identity cross-reference manages within the Affinity Domain. For example, where local domains have PIX Managers, the document sources and consumers obtain the normalized XAD patient ID from the Affinity Domain Patient Identity Source via the PIX Managers. The document sources and consumers can also obtain the XAD patient ID using other methods such as IHE PDQ or non-IHE approaches.

1000 For the sake of discussion, no assumptions are made on how document sources and consumers interact with the XAD patient identity domain – it could be directly or through a local domain X-ref manager.

1005 Further information on integrating Source and Consumer actors in XDS and XDS-I.b with other IT Infrastructure actors for exchanging patient identifying data across identity domains can be found in [ITI TF-1: E.3, E.4, E.5](#).

G.2 Patient Information Reconciliation (PIR) in an Affinity Domain

1010 PIR workflow within a local domain is well understood and addressed within the IHE PIR Integration Profile. However, within an XDS affinity domain, there is the added complexity of managing patient information within the XDS Registry and synchronizing data between the document sources, repository and registry.

G.2.1 Patient Merge within XAD Patient Identity Domain

- XAD patient identity domain merges two patients
 - Document sources are unaware of the merge transaction within XAD patient identity domain
- 1015

In this situation:

- XDS Registry receives a merge notification from the XAD patient identity source and applies merge logic to the registry
 - Document consumers have continued access to documents pertaining to the patient since consumers are expected to obtain the XAD patient ID for the patient at the time of querying the Registry
 - Document sources are unaware of the merge transaction that occurred in the XDS registry and do not need to be made aware of this merge. The reasons for this are:
 - o Consumers have continued access to the document
- 1020

- 1025 o The document source must query for the XAD patient ID before attempting to interact with the repository and registry. As such, the document source will have an updated XAD patient ID at the time of interacting with the registry.
- 1030 o When a document source wishes to submit a change to the document:
- 1030 o The document source must query for the XAD patient ID before registering the new document
- 1035 o The document source must register the new document with a request to deprecate the old document. From the document source’s perspective, the old document is still associated with the original XAD patient ID. By virtue of obtaining a new XAD patient ID for the patient, the document source must assume that a patient merge has taken place and use the new XAD patient ID to deprecate the old document

The process flow is described in more detail as follows:

Scenario:

- Key identifier for a patient within the XAD patient identity domain changes, such as health number
- 1040 • The XAD patient identity source merges two patients

Process Steps:

1. The XAD patient identity source sends a “merge” notification to the XDS Registry
 2. XDS Registry applies merge logic to the patients within the merge notification
- 1045 • The metadata in the registry will be accurate with the exception of the source patient ID

G.2.2 Local Domain Patient Update - XAD Domain Patient ID does not change

- Demographics for the patient change
 - Local domain patient ID does NOT change
 - XAD patient ID does NOT change
- 1050 In this scenario:
- XDS Registry does nothing since the XAD patient ID has not changed
 - If a document source changes the patient demographics content of a document and a new document is created then this document should be registered with the XDS repository/registry as a replacement to the old document

1055 The process flow is described in more detail as follows:

Scenario:

- Patient first name is corrected from “Jamie” to “James” in the local domain patient identity source

Process Steps:

- 1060 1. Update information flows from the local domain patient identity source (i.e., ADT) to the document source: image manager/archive.
- Document source updates its database to correct demographics
 - Either: Document source does not change the document
 - o The Document Source does not update the repository/registry. In this scenario, the patient demographics: Name, DoB, Sex, etc.; in the Document Source do not match those in the XDS Registry. This is acceptable in the XDS Profile.
 - Or: Document source changes the document
 - o The Document Source updates the repository/registry with an addendum.
- 1065 2. The Registry takes no action as the XAD patient ID has not changed

1070 **G.2.3 Local Domain Patient Update - XAD Domain Patient Merge**

- Demographics for the patient change
 - Local domain patient ID does NOT change
 - XAD patient ID does change and triggers a merge within XAD domain
 - Document sources are unaware of the merge transaction within XAD patient identity domain
- 1075

In this scenario:

- See Section G.2.1 Patient Merge within XAD Patient Identity Domain

The process flow is described in more detail as follows:

Scenario:

- 1080
- Patient last name is corrected from “Alfonsp” to “Alfonso” within local domain patient identity source
 - XAD domain patient identity source merges “Alfonsp: XAD-Pp” into “Alfonso: XAD-Pa” – patient “Alfonso” was already registered within the XAD domain with patient ID XAD-Pa

1085 **Process Steps:**

- See Section G.2.1 Patient Merge within XAD Patient Identity Domain

G.2.4 Local Domain Patient Merge – XAD Domain Patient ID does not change

- Demographics for the patient changes
 - Local domain patient identity source merges patient A with patient B
- 1090
- XAD patient ID for patient A and patient B are the same

In this scenario:

- XDS Registry does nothing since the XAD patient ID for patient A and patient B is the same
- 1095 • Document sources apply merge logic to the documents within their database i.e., documents are now associated with a new local domain patient ID
- Document sources must now query XAD patient identity source to obtain the XAD patient ID for the merged patient
- The XAD patient ID is the same as already associated with the document:
 - 1100 o If the document source does not change the document content, the document source does not need to interact with XDS Repository/Registry – status quo
 - o If the document source changes the patient demographics content of a document and a new document is created, then this document should be registered with the XDS repository/registry as a replacement to the existing document.

The process flow is described in more detail as follows:

1105 **Scenario:**

- Patient last name is corrected from “Smythe” to “Smyth”
- ADT already has an entry for “Smyth”
- “Smythe” with local domain patient ID D-123 is merged with Smyth with local domain patient ID D-456
- 1110 • XAD Patient Identity Source already recognized “Smythe: D-123” and “Smyth: D-456” as the same patient and, therefore, assigned each with the same XAD patient ID: XAD-Px

Process Steps:

1. Update information flows from the local domain patient identity source (i.e., ADT) to the document source: image manager/archive.
 - 1115 • Document source applies merge logic to the database: documents for the merged patient are associated with the new patient ID
2. Document source queries the XAD patient identity domain to determine whether the XAD patient ID has changed for the merged documents. In this case the XAD patient ID does not change
- 1120 3. Document source updates the demographics of the document
 - Either: Document source makes no changes to the document – demographics are in the database
 - 1125 o The Document Source need not update the repository/registry. In this scenario, the patient demographics in the Document Source do not match those in the XDS Registry. This is acceptable in the XDS framework

- Or: Document source changes the document
 - o The Document Source updates the repository/registry with an addendum.
- 4. The Registry takes no action as the XAD patient ID has not changed

G.2.5 Local Domain Patient Merge – XAD Domain Patient Merge

- 1130
- Demographics for the patient changes
 - Local domain patient identity source merges patient A with patient B
 - XAD patient IDs for patient A and patient B are different
 - Patient A is merged with patient B in the XAD domain patient identity source

There are three situations that can occur:

- 1135
1. XDS Registry merge prior to Document Source merge
 - XDS Registry receives a merge notification from the XAD patient identity source and applies merge logic to the registry
 - Document Sources are unaware of the merge transaction that occurred in the XDS registry and do not need to know about this transaction (see Section G.2.1)
- 1140
- Document Consumers have continued access to documents pertaining to the patient since consumers are expected to obtain the XAD patient ID for the patient at the time of querying the Registry
 - Document Sources apply merge logic to the documents within their database i.e., documents are now associated with a new local domain patient ID
- 1145
- Document Sources must now query XAD patient identity source to obtain the XAD patient ID for the merged patient
 - The XAD patient ID for the documents has changed:
 - o The Document Source changes the XAD patient ID associated with the documents – it can assume that the Registry has made this change as well
- 1150
- o If the Document Source does not change the document content, the document source does not need to interact with XDS Repository/Registry – status quo
 - o If the Document Source changes the patient demographics content of a document and a new document is created then this document should be registered with the XDS Repository/Registry – the existing document is deprecated.
- 1155
2. Document Source merge prior to XDS Registry merge
 - Document Sources apply merge logic to the documents within their database i.e., documents are now associated with a new local domain patient ID

- Document Sources must now query XAD patient identity source to obtain the XAD patient ID for the merged patient
- 1160 • The XAD patient ID is the same as already associated with the document:
 - o If the Document Source does not change the document content, the Document Source does not need to interact with XDS Repository/Registry – status quo
 - o If the document source changes the patient demographics content of a document and a new document is created, then this document should be registered with the
- 1165 XDS Repository/Registry as a replacement to the old document
- XDS Registry receives a merge notification from the XAD patient identity source and applies merge logic to the registry
- Document Sources are unaware of the merge transaction that occurred in the XDS registry and do not need to know about this transaction
- 1170 • Document Consumers have continued access to documents pertaining to the patient since consumers are expected to obtain the XAD patient ID for the patient at the time of querying the Registry
- 3. Document Source merge at same time as XDS Registry merge
- Document Sources apply merge logic to the documents within their database i.e., documents are now associated with a new local domain patient ID
- 1175 • Document Sources must now query XAD patient identity source to obtain the XAD patient ID for the merged patient
- The XAD patient ID is the same as already associated with the document
- XDS Registry receives a merge notification from the XAD patient identity source and applies merge logic to the registry
- 1180 • Document Source chooses to change the patient demographics content of a document and a new document is created. This document is registered with the XDS repository/registry:
 - o The XAD patient ID for this document has now been merged in the XDS Registry and, therefore, is no longer valid
 - o The Registry will reject the document registration transaction as the XAD patient ID used in the transaction is no longer valid.
 - o Document Sources must now query XAD patient identity source to obtain the
- 1185 XAD patient ID for the merged patient and re-register the document with the
- 1190 XDS repository/registry

Scenario:

- Patient last name is corrected from “Smythe” to “Smyth”

- ADT already has an entry for “Smyth”
 - Smythe: patient ID D-123 is merged with Smyth: patient ID D-456
- 1195 • XAD Patient Identity Source has separate entries for both “Smythe: XAD-Pc” and “Smyth: XAD-Pf”. As such, it merges these two patients in to “Smyth: XAD-Pf”.

Process Steps:

The process flow is a combination of the previous scenario process flows and thereby, not repeated here.

1200

Appendix H: Security considerations for XDS-I.b (informative)

1205 The Cross-Enterprise Document Sharing for Imaging (XDS-I.b) Profile does not specify all the details of the security environment for exchanging radiology information. The IHE IT Infrastructure Technical Framework includes several security profiles that apply to the XDS/ XDS-I.b use. The use of these security profiles in the first trial implementation for XDS-I.b will likely be optional. The security profiles make assumptions about the overall security environment and are configurable to adapt to different security requirements.

1210 Figure H-1 shows typical transactions for XDS-I.b. Each transaction goes through security and privacy controls. This figure illustrates use of firewall access points and TLS controls for all XDS-I.b participants, including the Imaging Document Source. The firewalls may have simple easy to implement rules or more complex rules depending upon local policies. The flows shown in Figure H-1 are described in more detail below:

Flow #1, The Store Images, etc. transactions:

- a) Internal firewall rules I:
 - 1215 - Simple rules: “outgoing HTTP is OK”
 - Complex rules: examine source IP, destination IP, HTTP headers to decide whether to permit the connection.
- b) TLS within each actor:
 - IM/IA: Is this really the authorized Image Document Source that was requested?
 - 1220 - Repository: Is this really an authorized IM/IA?
- c) Once the TLS connection is established there is further processing, generation of audit records, etc.

Flow #2, The Provide and Register Imaging Document Set transaction:

- 1225 a) does not cross a firewall
- b, c) TLS, authorization, auditing as above.

Flow #3, The Register transaction

- a) External firewall rules II:
 - 1230 - Simple: Outgoing HTTP is OK
 - Complex: examine source IP, destination IP, HTTP headers to decide whether to permit the connection.
- b, c) TLS, authorization, auditing as above.

1235 **Flow #4**, Query Documents transaction:

a) External firewall access rules II:

- Simple: Incoming HTTP to the DMZ is OK
- Complex: very tricky given many different uses for HTTP incoming by different web applications.

1240 b, c) TLS, authorization, auditing as above.

Flow #5, Retrieve Images, etc. transactions:

a) External firewall access rules III:

- Simple: Incoming DICOM is only permitted from authorized affinity domain IP blocks.
- 1245 - Complex: Examine the DICOM retrieve connection initiator and the targeting acceptor IP addresses, and permit only connections between a priori authorized pairs of initiator and acceptor.

b, c) TLS, authorization, auditing as above.

1250 This example shows access for both HTTP and DICOM traffic. It is easier to get multi-layer protection for the DICOM traffic because it is easily differentiated from the many diverse uses of HTTP for web applications and services. Then the TLS security, actor authorization rules, and auditing are applied to all traffic regardless of type.

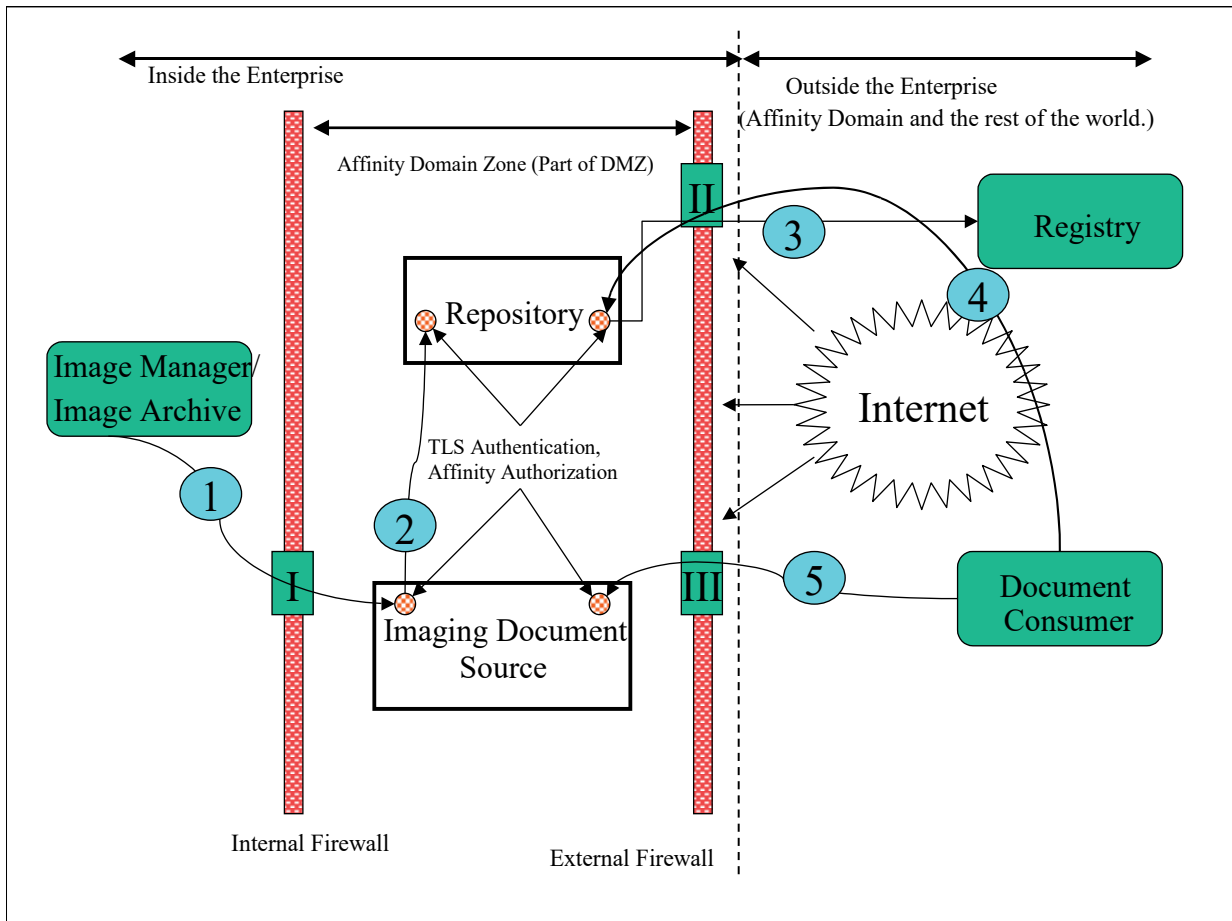

1255

Figure H-1: Security Environment

IHE assumes that there will be some form of external control point. This usually involves technologies like VPNs, firewalls, routers, etc. IHE does not specify what is necessary here, and the IHE profiles will operate and provide a good level of security even when the external control point is missing.

1260

The purpose of having an external control point is:

- To control the low-level network access between the Internet and the Imaging Document Source and Document Repository. The precision of this control is up to the sites involved. One common configuration is to merely restrict the list of IP Ports that are permitted access. This simplifies the security requirements on the server.
- Log and monitor all traffic for indications of hostile or abusive activity. This is usually a combination of logging and intrusion detection (IDS) activity that is oriented towards the overall IT organization requirements.

1265

1270 This kind of protection is useful and complements the encryption and access controls defined as part of IHE’s Audit Trail and Node Authentication (ATNA) Profile and its Radiology Audit Trail Option.

1275 The internal network is probably divided into two or more zones that are isolated by internal control points. These internal control points are similar to the external control point, but usually are much more permissive in terms of the traffic that they allow. They exist both to detect problems and to provide a means of rapidly isolating portions of the network in the event of a security breach.

1280 The Imaging Document Source is assumed to be located in the zone labeled the “Affinity Domain Zone”. This might also be part of a general DMZ (De-Militarized Zone) for the organization or it might be a special zone reserved exclusively for Affinity Domain activities. There are cost and functionality tradeoffs involved in making that decision and the IHE profiles support both approaches.

IHE will specify the minimum-security requirements for the Imaging Document Source. It will be expected to comply with the IHE ITI Audit Trail and Node Authentication (ATNA) Integration Profile. There may be multiple Imaging Document Sources in the Affinity Domain Zone and they will all be expected to comply with the ATNA Profile. This profile mandates:

- 1285 • All connections that might transfer protected health information (PHI) must utilize TLS configured to:
 - o Authenticate both machines involved
 - o Ensure that all traffic is encrypted, either directly by TLS or by means of equivalent protection such as VPN.
- 1290 • Enforce access control to the system
- Provide a detailed security audit trail for all PHI related activity and information transfers

The TLS protocol is also widely known as HTTPS. The ATNA Profile mandates this protection for any DICOM, HL7, HTTP or other protocols.

1295 There may be special auditing requirements for an XDS-I.b actor. For example, in the US there are HIPAA requirements for disclosure logs. Only the sites themselves can determine what belongs in a disclosure log. The ATNA logs were not directly intended for this purpose.

1300 The Imaging Document Source may be a system that is complete with its own image archive, or it may be a proxy machine that relays information to another machine, perhaps located in a private zone. This is considered an internal design issue by IHE. The XDS-I.b Profile specifies that the Imaging Document Source must support the XDS-I.b transactions, and does not specify the internal design.

There are several important design considerations for securing XDS-I.b networks that must be made by the affinity domain and its members. These are:

- 1305 1. What kind of external control points are used? IHE recommends that they be present, but does not profile them.

2. How to subdivide the enterprise network and whether to establish a dedicated Affinity Domain Zone. There is an advantage to creating an Affinity Domain Zone with just a few servers located in it:
 - a. The log analysis is easier
 - 1310 b. The certificate and TLS management for node authentication is easier
 - c. The preparation of disclosure logs and the equivalent is easier.
 - d. The internal control point reduces the risks from a breach of the Affinity Domain Zone.

- 1315 3. Whether User Authentication is needed. IHE provides both the ITI Enterprise User Authentication (EUA) ([ITI TF-1: 4](#)) and the Cross-Enterprise User Assertion (XUA) ([ITI TF-1: 34](#)) Profiles. Use of user authentication permits additional information to be captured in the audit logs (e.g., the identity of the user) and permits additional access control in some situations. The issues that the affinity domain and sites must address are:
 - 1320 a. What to do about automated processes, such as pre-fetch and email. These can be identified using node authentication via TLS as specified in ATNA, by using simple identity assertions.
 - b. How to handle delegation. Often it is clerks, nurses, etc. that are actually operating the computer to obtain the records for a patient, and it is someone else that will actually be examining the records. So, the user authentication might not provide any
1325 further useful information.

The IHE profiles do not determine these choices. Some reasonable selections include:

 1. Not using user authentication. The ATNA ensures that the enterprise and the machine are authenticated. These machines are already authenticated and trusted to protect PHI information. It may be impractical to track and coordinate the
1330 personnel activities across all the different organizations.
 2. Though not specifically designed for this purpose, it is also possible that the XDS-I.b Profile is being used internally within a centrally controlled large organization, where the Kerberos based identity management of EUA is available. EUA can be used in such an intra-enterprise environment. EUA supports simple identity
1335 assertions. These are based on trusting the authenticated node to provide the correct identity of its user.
 3. The use of XUA is optional. Where a human user is involved, XUA can be employed for cross-enterprise user identity assertion. If only machines are involved, the node authentication provided by ATNA should be sufficient. The
1340 use of XUA requires that the affinity domain establish the authentication policies, procedures, and have a supporting infrastructure of servers, etc. (This infrastructure may be provided by the local government or might need to be provided by the affinity domain.)

1345 Note: In order to use the XUA Profile, the underlying application protocol must be able to carry a user identity assertion in its payload. While such a mechanism has been established in HL7 and HTTP/S, the mechanism to provide this for DICOM messages is still under development. Thus, XUA Profile cannot (yet) be employed when retrieving DICOM SOP Instances referenced in the manifest document.

1350 The affinity domain and individual site policies will determine the choices made. There are IHE profiles defined to address these alternatives.

Appendix I: Deployment of Dose Registries

1355 The Radiation Exposure Monitoring (REM) Profile is intended to facilitate Dose Registry projects. Participating sites that have implemented the REM Profile can be depended on to provide data with known contents in a known format and will all support a common transport mechanism. See the Submit Dose Information transaction for details (RAD TF-2: 4.63).

This appendix includes discussions of logistical issues related to the deployment of dose registries. This is not part of the normative text of the REM Profile, but the discussions here may be helpful when deploying and using the REM Profile.

I.1 Dose Registry Deployment Issues

1360 I.1.1 Code Set Management

Although the REM Profile does manage to provide consistent dose data, for a Dose Registry to analyze dose objects and prepare summary statistics for a specific exam type, anatomy or pathology/indication, it will need to select/group dose objects based on exam type, anatomy or pathology/indication.

1365 If the different sites submitting data used consistent code sets for coding such details, this might be easy, but unfortunately, for technical and organizational reasons, such code set consistency is unlikely. Due to similar issues, consistency *within* an organization may even be challenging.

1370 Dose Registries should be prepared to deal with such non-uniformity. For example, they may need to manage lookup tables to map codes from each submitting organization to a set of standard codes or categories. This may involve reverse engineering the codes from Code Description fields, when available, or it may involve requesting code sets from participating sites.

Dose Registries should also be prepared for a lack of detail e.g., there may be a procedure code for “stent placement” but no indication if it was one stent, three stents, or more.

1375 I.1.2 Configuration of Secure FTP (Submit Dose Information [RAD-63])

The REM Profile requires Dose Information Reporters support the Submit Dose Information Transaction for the purpose of submitting dose data to Dose Registries.

The Submit Dose Information Transaction specifies the use of FTP over TLS.

When setting up the FTP server the dose registry project should consider useful features such as:

- 1380
- Setting up individual login accounts for each participating site
 - Directing files from clients into specific folders based on their login account id
 - Preventing clients from looking at other folders

I.1.3 Alternative Transport Mechanisms

1385 The DICOM STOW-RS transport mechanism defined in the Submit Dose [RAD-63] transaction is intended to provide a baseline transport mechanism. It is not intended to prohibit Dose Registry projects from using other transport mechanisms, as long as they also support the baseline mechanism.

Some alternative transport mechanisms to consider include sending the objects via:

- CD using the IHE Portable Data for Imaging (PDI) Profile
- 1390 • Secure FTP (which was defined in the original REM Profile but has been removed)
- Email using the DICOM Email Media Profile and SMTP (XDM)
- Network using DICOM C-STORE over TLS or a VPN to a DICOM Storage SCP
- Network using the IHE Cross-Enterprise Document Sharing for Imaging (XDS-I) Profile
 - 1395 o Note the need to establish an Affinity Domain covering all contributing sites and to fill in the XDS metadata which may be complicated by de-identification.
 - o Note also the need to provide an Imaging Document Source at the provider end, since XDS-I does not “push” the dose objects themselves to the recipient, but rather registers their availability, requiring them to then be “pulled”.
- 1400 • Network using the IHE Cross-Enterprise Document Reliable Interchange for Imaging (XDR-I) Profile
 - o This might be attractive if XDR-I features such as multi-file bundles, and “replacing” documents would be useful.
 - o Note again the need to fill in the XDS metadata.

I.1.4 Encapsulated Dose Registry Submission

1405 Another approach to addressing submission issues and facilitating site is for the organization that is setting up a dose registry project to develop and distribute a client application to each participating site.

1410 The client includes an implementation of a Dose Information Consumer or Dose Information Reporter which allows it to gather dose objects from the Image Archive. The client would also incorporate a proprietary upload mechanism to get the dose objects up to the dose registry.

Note that while this approach has the potential to simplify some technical issues, it introduces a number of security issues. Some sites may need to review and approve such a client before allowing foreign software on their network, particularly if it is capable of sending patient data outside the organization.

1415 Imagine:

- the XYZ Dose Registry Client implements the Dose Information Consumer to get dose objects, and some email or web services protocol to send them to the Dose Registry

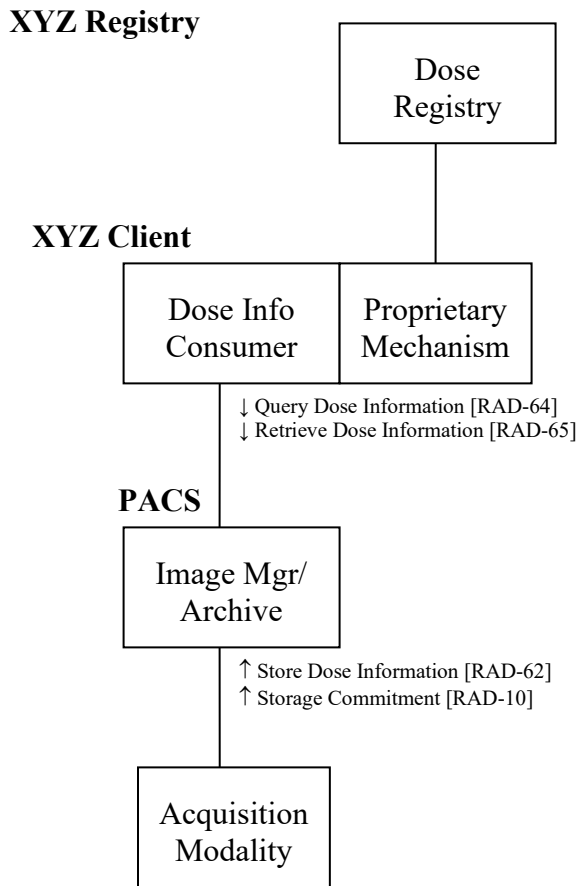

1420 **I.2 Real-World Projects**

A number of organizations have established or are in the process of establishing Dose Registry projects.

Project: ACR Registry - USA

1425 ACR is forming a national Dose Index Registry (DIR). The initial pilot program will compare CT dose indices across 10-12 facilities to identify areas that may require changes to CT dose protocols. At the completion of the pilot program, the DIR will launch nationwide.

Their ultimate goal is minimizing dose to the patient population and they are interested in Use Cases including: Population Dose and Dose Indicators, Dose Reference Levels and Benchmarking. They are specifically not interested in the Patient Dose History Use Case as they
 1430 have no plans to become a national personal dose record.

Website: nrdr.acr.org

Project: French Ministry of Health Registry

1435 French regulations mandate the submission of Dose Reference Level data to a federal dose registry managed by the Institut de Radioprotection et de Sûreté Nucléaire / Institute for Radiation Protection and Nuclear Safety (IRSN).

Every year each specialist must submit dosimetric information (at least 20 patients) for each of at least two examination types (generally the most frequent and most irradiating examination types).

1440 The ministry is interested in Use Cases including: Population Dose and Dose Indicators, and Dose Reference Levels. Data collection spans Radiography, Fluoroscopy, Mammography, Computed Tomography and Nuclear Medicine. The data is further broken down by patient age category, and body part.

Website: <https://www.irsn.fr/EN/Pages/home.aspx>

I.3 Dose Monitoring Regulations

1445 Several groups interested in regulatory issues (IEC, FDA, AAPM, etc.) drove original definition of the DICOM Dose SR objects.

The following sections contain some contributed summaries of different regulatory initiatives. These are only intended to provide a sense of the type of activities. Readers should refer to the regulations themselves for accurate information.

1450 European Regulatory

European regulation is based on European Directive Euratom 1997/43/EC. The application of the directive is mandatory in all EU countries (27 today) since 2000. All European national regulations have to be compatible with the directive. Different countries have varied in their reactions/actions to Euratom.

1455 Euratom specifies a follow up for each patient and statistical analysis at the population level.

Euratom: http://ec.europa.eu/energy/nuclear/radioprotection/legislation_en.htm

Diagnostic Reference Levels (DRLs) in Europe:

http://www.eu-alara.net/index.php?option=com_content&task=view&id=156&Itemid=53

French Regulatory

1460 Today two regulations specify the dosimetric information that a user of ionising radiation must provide in France.

- One text, published in March 2004, concerns Dose Reference Levels (DRL) (Arrêté du 12 février 2004 relatif aux niveaux de référence diagnostiques en radiologie et en médecine nucléaire – Journal Officiel de la République Française du 16 mars 2004).
- Another text, published in September 2006, concerns dosimetric information that must be present in the medical record of the diagnostic examination (Arrêté du 22 septembre 2006

relatif aux informations dosimétriques devant figurer dans un compte rendu d'acte utilisant les rayonnements ionisants - Journal Officiel de la République Française du 29 septembre 2006).

- 1470 For each medical procedure using ionising radiation, the medical record must include information allowing estimation of the dose received by the patient.

German & Dutch Regulatory

In Germany and the Netherlands, dose information is not conveyed above the Hospital level. Dose information is required and must be auditable.

- 1475 Germany is working on additions to the DICOM Basic Diagnostic Imaging Report to include Radiation Regulation related details such as:

- Pregnancy Status
- Indications for Procedure
- Physician Responsible for Indication
- Performing Person (who administered)
- Radioactive Substance Administered
- Radiation Exposure (text description of "the exposure")
- Performing Person's Organization Name

1480

Spanish Regulatory

- 1485 In Spain, dose information is not conveyed above the Hospital level.

Dose information is required in order to audit the use of diagnostic equipment (comparing with Dose Reference Levels) and must be auditable by the responsible health authority. Also the responsible health authority and the Nuclear Security Council will guarantee that the distribution of the estimations of resulting individual doses is determined, for the population and the significant groups of reference of the population, whose results will be sent to the Ministry of Health and Consumption.

1490

GLOSSARY

1495 Please see the IHE Technical Frameworks General Introduction, [Appendix D - Glossary](#) for the complete IHE Glossary.

Terms Specific to this Document

1500 **Accession Number:** A user-friendly identifier created by the Departmental System, which identifies an instance of a filler order or imaging service request. It may group one or more requested procedures.

Actor: An entity within a use case diagram that can perform an action within a use case diagram. Possible actions are creation or consumption of a message.

Conventional 2D mammography: Refers to mammography images that have been acquired using FFDM.

1505 **Dose Object:** A persistent DICOM object (see DICOM PS3.3: A.35.8 X-Ray Radiation Dose SR IOD) for recording details related to Irradiation Events. DICOM has defined Dose Objects for CT and Projection X-ray procedures.

Dose Registry: A system that collects dose information from multiple sites, generally to perform analysis of Population Dose and Dose Indicators.

1510 **DVD:** A trademark of the DVD Forum that is not an abbreviation

1515 **Evidence Documents:** Evidence Documents represent the uninterpreted information that is primarily managed and used inside the imaging department, although distribution outside the imaging department is not precluded. Evidence documents are non-image information and include things such as measurements, CAD results, procedure logs, etc. and are to be encoded as DICOM SR documents.

1520 **Evidence Objects:** All objects generated as a result of performing procedure steps on systems in an imaging department. These objects are used by the reading physician in the process of creating a diagnostic report and are managed inside the imaging Department. Examples of evidence objects include: Images, Presentation States, Key Image Notes and Evidence Documents.

Expected Actions: Actions which should occur as the result of a trigger event

Foreign Key (FK): A database key that is used as a reference to relate one entity to another entity. It may be a unique value, or used in conjunction with another Foreign Key to create a unique value.

1525 **Hardcopy Import:** The process of importing non-digital data into the Enterprise as DICOM Objects. The original data may be Films or Documents that are scanned and stored as DICOM Objects.

Images Available: A transaction or transactions used to determine that images have been stored in an image archive and may be retrieved.

- 1530 **Interaction Diagram:** A diagram which depicts data flow and sequencing of events
- Interchange Media:** A piece of data-bearing physical media, such as a CD or DVD. The term, which is used in the DICOM standard, is synonymous with “portable media” or “transfer media”.
- Irradiation Event:** An irradiation event is one continuous occurrence of irradiation being applied to a patient. A pulsed fluoro X-Ray acquisition, or a multi-slice helical CT scan are examples of single events; while a CT scanogram and the helical scan, or two different presses of the fluoro pedal, or simultaneous irradiation from two X-ray tubes are examples of separate events. See RAD TF-2: 4.62.4.1.1 in Store Dose Information for a more detailed description
- 1535 **Pre-fetch:** The activity of fetching images or other information objects from previously completed procedures to near-term storage for review of those data.
- 1540 **Process Flow Diagram:** A graphical illustration of the flow of processes and interactions among the actors involved in a particular example
- Role:** The actions of an actor in a use case.
- Scope:** A brief description of the transaction.
- Slab:** A thick slice tomosynthesis reconstruction (e.g., greater than 1mm).
- 1545 **Trigger Event:** An event such as the reception of a message or completion of a process, which causes another action to occur.
- Use Case:** A graphical depiction of the actors and operation of a system.
- W3C:** A trademark of the World Wide Web Consortium that is not an abbreviation
- Web-Viewable:** Browsable using a web browser (e.g., XHTML files and JPEG images)
- 1550 **XDS Imaging Document:** An XDS Imaging Document is the smallest unit of imaging related information that may be provided to a Document Repository and registered in a Document Registry. An XDS Imaging Document may contain a manifest of images (e.g., DICOM Key Object Selection document) or a radiology report provided either as a PDF document or as structured and vocabulary coded clinical information (e.g., CDA^{®3} Release 2).
- 1555
- DICOM Terms**
- Basic Color Print Management Meta SOP Class:** See DICOM PS3.4
- Basic Grayscale Print Management Meta SOP Class:** See DICOM PS3.4
- Basic Text SR Storage SOP Class:** See DICOM Supplement 23
- 1560 **DICOM Model of the Real World:** See DICOM PS3.3
- Enhanced SR Storage SOP Class:** See DICOM Supplement 23

³ CDA is the registered trademark of Health Level Seven International and the use does not constitute endorsement by HL7.

- Grayscale Softcopy Presentation State Storage SOP Class:** See DICOM PS3.4
- Grayscale Standard Display Function:** DICOM PS3.14
- Imaging Service Request:** See DICOM PS3.3
- 1565 **Modality:** See DICOM PS3.3
- Modality Worklist SOP Class:** See DICOM PS3.4
- Modality Performed Procedure Step:** See DICOM PS3.3
- Modality Performed Procedure Step Information Module:** See DICOM PS3.3
- Modality Performed Procedure Step Relationship Module:** See DICOM PS3.3
- 1570 **Modality Performed Procedure Step SOP Class:** See DICOM PS3.4
- Patient:** See DICOM PS3.3
- Patient Identification Module:** See DICOM PS3.3
- Print Presentation LUT SOP Class:** See DICOM PS3.4
- Procedure Plan:** See DICOM PS3.3
- 1575 **Procedure Type:** See DICOM PS3.3
- Protocol Code:** See DICOM PS3.3
- Requested Procedure:** See DICOM PS3.3
- Requested Procedure Module:** See DICOM PS3.3
- Requested Procedure ID:** See DICOM PS3.3
- 1580 **Results Information Object Definition:** See DICOM PS3.3
- Scheduled Procedure Step:** See DICOM PS3.3
- Scheduled Procedure Step Module:** See DICOM PS3.3
- Storage Commitment SOP Class:** See DICOM PS3.4
- Stored Print SOP Class:** See DICOM PS3.4
- 1585 **Structured Reporting Information Object Definitions:** See DICOM PS3.3
- Structured Reporting SOP Classes:** See DICOM PS3.4
- Structured Reporting Templates:** See DICOM PS3.16
- Unique Identifier (UID):** See DICOM PS3.5
- 1590 **HL7 Terms**
- ADT:** See HL7 version 2.3.1
- Battery:** See HL7 version 2.3.1

Filler: See HL7 version 2.3.1

Observation: See HL7 version 2.3.1

1595 **Placer:** See HL7 version 2.3.1

Universal Service ID: See HL7 version 2.3.1

Acronyms and Abbreviations

ACR: American College of Radiology

1600 **CAD:** Computer Aided Detection

CD: Compact Disk

DAP: Dose Area Product

DBT: Digital Breast Tomosynthesis

DLP: Dose Length Product

1605 **FDA:** Food and Drug Administration (USA)

FFDM: Full Field Digital Mammography

FSC: File-Set Creator

FSR: File-Set Reader

GSPS: Grayscale Softcopy Presentation State

1610 **HIMSS:** Healthcare Information and Management Systems Society

HIS: Hospital Information System

HTML: Hyper Text Markup Language

ICRU: International Commission on Radiological Units

IEC: International Electrotechnical Commission

1615 **IHE:** Integrating the Healthcare Enterprise

IOD: Information Object Definitions

IT: Information Technology

JPEG: Joint Photographic Experts Group

LUT: Look Up Table

1620 **MPI:** Master Patient Index

MPPS: Modality Performed Procedure Step

MQSA: Mammography Quality Standards Act of 1992

MWL: Modality Worklist

NEMA: National Electrical Manufacturers Association

1625 **PACS:** Picture Archive and Communication System

PHI: Protected Healthcare Information

PPS: Performed Procedure Step

PSD: Peak Skin Dose

QA: Quality Assurance

1630 **RIS:** Radiology Information System

RSNA: Radiological Society of North America

SCU: Service Class User

SCP: Service Class Provider

SR: Structured Report

1635 **UID:** Unique Identifier

USB: Universal Serial Bus

XHTML: eXtensible Hypertext Markup Language

References

1640 [1] American College of Radiology White Paper on Radiation Dose in Medicine, E. Stephen Amis, et al, Journal of American College of Radiology, 2007, Vol. 4, pp. 272-284

[2] Quality Improvement Guidelines for Recording Patient Radiation Dose in the Medical Record, Donald Miller, Stephen Balter, et al, Journal of Vascular Interventional Radiology, 2004, Vol. 15, pp. 423-429

1645 [3] ICRU. Report 74: Patient Dosimetry for X-Rays Used in Medical Imaging. JICRU 5; 2005.

[4] IEC. IEC 60601. (2000). Medical electrical equipment - Part 2-43: Particular requirements for the safety of X-ray equipment for interventional procedures. Geneva; 2000.

[5] IEC. PAS 61910-1 Radiation Dose Documentation Part 1: Equipment for radiography and radioscopy. Geneva; 2007.

1650 [6] FDA. Federal performance standard for diagnostic x-ray systems and their major components-- FDA. Final rule. Fed Regist 70: 33998 - 34042; 2005.

[7] Capturing Patient Doses from Fluoroscopically Based Diagnostic and Interventional Systems, Stephen Balter, NCRP Annual Meeting-07; 2008