



5

# **IHE Radiology Technical Framework Supplement**

## **Multiple Image Manager/Archive (MIMA)**

10

### **Trial Implementation**

15

Date: September 30, 2010

Author: David Heaney

20 Email: radiology@ihe.net

## Foreword

This is a supplement to the IHE Radiology Technical Framework V9.0. Each supplement undergoes a process of public comment and trial implementation before being incorporated into the volumes of the Technical Frameworks.

- 25 This supplement is submitted for Trial Implementation as of September 30, 2010 and will be available for testing at subsequent IHE Connectathons. The supplement may be amended based on the results of testing. Following successful testing it will be incorporated into the Radiology Technical Framework. Comments are invited and may be submitted on the IHE forums at <http://forums.rsna.org/forumdisplay.php?f=12> or by email to radiology@ihe.net.
- 30 This supplement describes changes to the existing technical framework documents and where indicated amends text by addition (**bold underline**) or removal (~~**bold strikethrough**~~), as well as addition of large new sections introduced by editor's instructions to "add new text" or similar, which for readability are not bolded or underlined.
- 35 "Boxed" instructions like the sample below indicate to the Volume Editor how to integrate the relevant section(s) into the relevant Technical Framework volume:

<i>Replace Section X.X by the following:</i>
--

General information about IHE can be found at: [www.ihe.net](http://www.ihe.net)

- 40 Information about the IHE Radiology Domain can be found at:  
<http://www.ihe.net/Domains/index.cfm>

Information about the structure of IHE Technical Frameworks and Supplements can be found at:  
<http://www.ihe.net/About/process.cfm> and <http://www.ihe.net/profiles/index.cfm>

- 45 The current version of the IHE Technical Framework can be found at:  
[http://www.ihe.net/Technical\\_Framework/index.cfm](http://www.ihe.net/Technical_Framework/index.cfm)

**CONTENTS**

	Introduction.....	4
50	Profile Abstract .....	4
	Closed Issues .....	4
	<b>Volume 1 – Integration Profiles.....</b>	<b>8</b>
	2.1 Dependencies among Integration Profiles .....	8
	3 Scheduled Workflow (SWF).....	20
55	3.1 Actors/Transactions.....	21
	3.2 Scheduled Workflow Integration Profile Options .....	22
	3.2.1 Multiple Identity Resolution Option .....	25
	3.3 Scheduled Workflow Process Flow .....	28
	3.3.7 Multiple Identity Resolution Option Process Flow .....	28
60	4 Patient Information Reconciliation (PIR) .....	36
	4.1 Actors/Transactions.....	36
	4.2 Patient Information Reconciliation Integration Profile Options .....	37
	4.2.1 Multiple Identity Resolution Option .....	38
	4.4 Use Cases .....	38
65	4.4.7 Case 7: Multiple Identity Resolution Option - Unidentified Patient Sent to Centralized Archive .....	38
	<b>Volume 2 – Transactions.....</b>	<b>43</b>
	4.4 Procedure Scheduled Message.....	43
	4.6 Modality Procedure Step In Progress.....	46
70	4.7 Modality Procedure Step Completed/Discontinued.....	48
	4.8 Modality Images Stored .....	49
	4.13 Procedure Update .....	50
	4.14 Query Images .....	52
	4.15 Query Presentation States .....	53
75	4.16 Retrieve Images.....	54
	4.17 Retrieve Presentation States.....	55
	4.18 Creator Images Stored.....	56
	4.19 Creator Presentation State Stored.....	57
	4.20 Creator Procedure Step In Progress .....	58
80	4.21 Creator Procedure Step Completed.....	60
	4.29 Key Image Note Stored.....	61
	4.30 Query Key Image Notes.....	62
	4.31 Retrieve Key Image Notes .....	63
	<b>Volume 3 – Transactions.....</b>	<b>64</b>
85	4.70 Image Manager Instances Stored .....	64
	4.70.1 Scope .....	64
	4.70.2 Use Case Roles.....	64
	4.70.3 Referenced Standards.....	64

	4.70.4 Interaction Diagram.....	65
90	4.71 Image Manager Storage Commitment .....	67
	4.71.1 Scope .....	67
	4.71.2 Use Case Roles.....	67
	4.71.3 Referenced Standards.....	67
	4.71.4 Interaction Diagram.....	67
95	4.72 Image Manager Instances Query.....	70
	4.72.1 Scope .....	70
	4.72.2 Use Case Roles.....	70
	4.72.3 Referenced Standards.....	70
	4.72.4 Interaction Diagram.....	71
100	4.73 Image Manager Instances Retrieval .....	74
	4.73.1 Scope .....	74
	4.73.2 Use Case Roles.....	74
	4.73.3 Referenced Standards.....	74
	4.73.4 Interaction Diagram.....	75
105	Appendix J: Multiple Identity Resolution Option .....	78
	J.1: Multiple Identity Resolution Use Cases .....	78
	J.1.1: Multiple Image Manager/Archives Within a Single Patient Identity Domain .....	78
	J.1.2: Single Image Manager/Archive Supporting Multiple Patient Identifier Assigning Authorities.....	79
110	J.1.3: Multiple Image Manager/Archives Supporting Multiple Patient Identifier Assigning Authorities.....	93
	J.2: Multiple Identity Resolution Transaction Specifications .....	105
	J.2.1: Cross-Referencing of Patient Identifiers .....	106
	J.2.2: Configurable Mapping to Default Assigning Authorities and Institution Name.....	107
115	J.2.3: Expected Actions when Receiving Scheduled or Updated Procedures.....	109
	J.2.4: Handling of Assigning Authorities when Exchanging SOP instances .....	109
	J.2.5: Handling of Assigning Authorities in Performed Procedure Steps .....	112
	J.2.6: Handling of Assigning Authorities in Queries .....	115
120		

## Introduction

- 125 This Supplement adds a new option to the Scheduled Workflow and PIR Profiles of the IHE Radiology Technical Framework. This new option adds support for transactions between Image Manager/Archives and also allows an Image Manager/Archive to support multiple patient identifier assigning authorities. This Supplement proposes changes to both Parts I and II of the IHE Radiology Technical Framework.

## Profile Abstract

- 130 Centralized (regional, national, or federated) multi-enterprise long term archives for diagnostic imaging are frequently being deployed now. Such architectures can involve transactions between local PACS and a centralized long term archive, with both types of systems normally being considered Image Manager/Archive 'actors'. A subset of similar issues arise for connectivity between Image Manager/Archives within a single patient identifier assigning authority domain.
- 135 None of the existing IHE Profiles define transactions between Image Manager/Archives and they also do not clearly describe the role of such a centralized archive in terms of which Actors and Profiles should be supported. The existing IHE SWF and PIR Profiles assume that there is a single patient id assigning authority and ordering system but the centralized archive will have to handle many such patient and ordering contexts.
- 140 The XDS-I Profile is not impacted by this Supplement.

## Closed Issues

#	Issue/ (Answer)
1.	<p><b>How should the new Image Manager to Image Manager transactions be added without making all current Image Manager/Archive implementations non-conformant?</b></p> <p><b>The approach taken is to add a new option to the existing Image Manager/Archive Actor defined for Scheduled Workflow.</b></p>

2.	<p><b>Should there be a single new Scheduled Workflow option or two options: one for handling multiple Assigning Authorities and another for basic Image Manager to Image Manager transactions?</b></p> <p><b>Decided to add one new option, Multiple Identity Resolution, rather than two. It was found that trying to split up the functionality into two separate options was very awkward, particularly when it came to detailing exactly how the query-retrieve interaction would work when only one of the Image Managers supports the cross-referencing of patient identifiers while the other does not.</b></p>
3.	<p><b>For existing transactions such as Modality Images Stored the responsibility for determining the assigning authority for the patient identifier and updating the DICOM headers will be placed on the receiving Image Manager rather than upon the sending Modality actor. This way existing Modalities and Evidence Creators that support SWF can still be supported without requiring modification.</b></p>
4.	<p><b>Taken from Data Synchronization Discussions:</b></p> <p><b>If there are two Accession Numbers for the same Study (i.e. Group Case, or two different orders for the same set of images, one site acquired and one reported) then Accession Number should be left blank. Request Attribute Sequence has to be used for the values.</b></p>
5.	<p><b>In our previous meetings it was felt by most that all HL7 transactions from the DSS/Order Filler should have to go through the local Image Manager/Archive. However, there do not appear to be any clear use cases that require such 'HL7 broker' functionality by the Image Manager/Archives. Unless there are clear use cases that necessitate that such functionality must be added to Image Manager/Archives then I cannot see a justification for taking such an approach. We run the danger of creating requirements which have no clear need and few will implement, particularly as legacy systems that do not incorporate such functionality will have to be supported by Multi-Enterprise Archive anyways.</b></p> <p><b>Agreed upon in meeting at IHE Connectathon.</b></p>
6.	<p><del><b>Do not add HLv2.5 support to this Supplement. The necessary changes will be done as a Change Proposal that also corrects many of the current inconsistencies.</b></del></p> <p><b>The issue of HL7v2.5 support should still be considered an Open Issue, and is documented in Open Issue 4.</b></p>
7.	<p><b>Considered making it mandatory for the Image Manager Instances Stored transaction to do a query first to see if the SOP Instances already exist on the peer AE before sending them. This idea was rejected.</b></p>
8.	<p><b>Multiple Identity Resolution Option must be added to PIR in addition to SWF.</b></p>

9.	<p><b>No changes are actually necessary for the XDS-I Profile. However, should the XDS-I Profile text in Part I be modified though so that it includes some use cases where there are Multiple Image Managers supporting the SWF Multiple Identity Resolution (i.e. so it is clear how to deploy a centralized archive that supports the Multiple Identity Resolution option along with the XDS-I infrastructure)?</b></p>
10.	<p><b>An Image Manager/Archive supporting multiple assigning authorities is going to have to receive patient identifier updates in order to maintain consistent cross-referencing of patient identifiers with the PIX Manager.</b></p> <p><b>Making the Image Manager/Archive support the Patient Identity Feed [ITI-8] transaction, like an XDS Registry, would mean making changes to the ITI Profile to add the Image Manager/Archive actor. Anyways, the SWF Patient Registration [RAD-1] and SWF/PIR Patient Update [RAD-12] Transactions which an Image Manager/Archive shall already support utilize a super-set of the same HL7 messages. Plus, the PIX Patient Identity Feed [ITI-8] messages are not guaranteed to contain the necessary cross-referencing information.</b></p> <p><b>Instead, this Supplement takes the approach of specifying that the Image Manager/Archive shall be grouped with a PIX Consumer. It thus shall support the PIX Query [ITI-9] transaction as a PIX Consumer, and optionally can support the PIX Update Notification [ITI-10] transaction.</b></p> <p><b>Currently this Supplement does not address the integration of support for the PAM Profile.</b></p>
11.	<p><b>The Multiple Identity Resolution option was not added for the Image Display, Acquisition Modality, and Evidence Creator actors. There does not appear to be much to gain for adding this, as the Image Manager/Archive supporting the Multiple Identity Resolution option shall support these actors even if they do not send Assigning Authority or Institution information.</b></p>
12.	<p><b>Does the Image Manager supporting the Multiple Identity Resolution option need to support both the PIX and PDQ Consumer actors?</b></p> <p><b>The current proposal only specifies PIX Consumer support because the essential requirement is obtain the cross-referencing of patient identifiers for a patient. Only a PIX Manager can supply that. A PDQ Supplier can only supply this if it is grouped with a PIX Manager or acts as a PIX Consumer itself to query for this identifier. This does differ from the IRWF Profile though which utilizes PDQ however.</b></p>
13.	<p><b>This Supplement proposes that an Image Manager supporting the Multiple Identity Resolution option shall support the ability to cross-reference patient identifiers for the same patient by being grouped with a PIX Consumer.</b></p> <p><b>It is recognized that an implementation may want to be reliant upon receiving updates by supporting just the PIX Update Notification transaction, and such an implementation is permitted. The Image Manager shall still support issuing a PIX Query though.</b></p>

14.	<b>Currently the new Multiple Identity Resolution option only mandates grouping with a PIX Consumer for the HL7 version 2.3 transactions. Decided not to make support for the PIX HL7 version 3 transactions mandatory.</b>
15.	<b>The Multiple Identity Resolution Option has not been added to the Report related Profiles and their transactions: Report Submission, Report Issuing, Query Reports, Retrieve Reports, and Structured Report Export transactions. Decision has been made to defer this to a future Supplement or Change Proposal, as we may want to address some of the larger issues, such as whether it still makes sense to have separate Image Manager and Report Manager actors.</b>
16.	<p><b>SWF requires an Acquisition Modality or Evidence Creator to include the Request Attributes Sequence (0040,0275) (or Referenced Request Sequence (0040,A370) for Structured Reports) so that a created SOP Instance contains details of the corresponding order. However, these existing specifications do not require the Issuer of Accession Number Sequence (0008,0051) to be conveyed if it is provided in the Modality Worklist. In addition, the Request Attributes Sequence does not currently include the Filler Order Number, Placer Order Number and their Assigning Authorities.</b></p> <p><b>It was decided not to make it mandatory for an Image Manager/Archive supporting the Multiple Identity Resolution option to add these attributes. The rationale for this decision was that it would be difficult for Image Managers to provide this information and make sure it is always correct and up to date in all use cases. It is felt that a receiving Image Manager could not always rely upon this information as being correct so the potential benefits of making this mandatory were outweighed by the implementation burdens and possible unreliability of the provided information.</b></p>
17.	<b>Decided to only require the use of namespace ID for the Patient ID Assigning Authority because that is what the current IHE Radiology transactions require. Current transactions do not require any Accession Number Assigning Authority information so the Multiple Identity Resolution option ‘raises the bar’ by making all three fields mandatory (namespaceID, universal ID and universal ID type).</b>
18.	<b>The Configurable Mapping to Default Assigning Authorities in Appendix J does not specify that the Image Manager/Archive shall check whether or not received Institution Name values are really correct. It shall assume that only received values in the Institution Name Code Sequence are correct as experience has shown that the Institution Name attribute is not used consistently.</b>



# Volume 1 – Integration Profiles

## 2.1 Dependencies among Integration Profiles

145

*Modify the dependencies in Table 2-1*

**Table 2-1. Integration Profiles Dependencies**

Integration Profile	Depends on	Dependency Type	Comments
Scheduled Workflow	<u>Patient Information Reconciliation</u>	<u>An Image Manager/Archive supporting the Scheduled Workflow Multiple Identity Resolution option shall also support that option in the Patient Information Reconciliation profile</u>	<u>Dependency is required as it is not permitted for an Image Manager to support the Multiple Identity Resolution option for Scheduled Workflow but not for Patient Information Reconciliation.</u>
	<u>Patient Identifier Cross-referencing [ITI]</u>	<u>Required for for an Image Manager/Archive supporting the Scheduled Workflow Multiple Identity Resolution option.</u>	<u>Patient identifier cross-referencing is obtained using PIX Query or PIX Update Notification.</u>
...			
Patient Information Reconciliation	Scheduled Workflow	Required for workflow/content to manage <u>An Image Manager/Archive supporting the Patient Information Reconciliation Multiple Identity Resolution option shall also support that option in the Scheduled Workflow profile</u>	Patient Information Reconciliation is an extension to this profile requiring that the workitems and/or content be updated.

*Add the following to TF vol 1, section 2.4 Transaction Descriptions*

- 150        **62. Image Manager Instances Stored – An Image Manager/Archive supporting the Multiple Identity Resolution option sends DICOM SOP Instances to another Image Manager/Archive.**
- 155        **63. Image Manager Storage Commitment - A requestor Image Manager/Archive supporting the Multiple Identity Resolution option requests that the receiving Image Manager/Archive confirm ownership for the specified DICOM objects (images, GSPS objects, Key Image Notes, Evidence Documents or any combination thereof) that the requestor stored in the Image Manager/Archive, thus allowing the requestor Image Manager/Archive to delete those objects now owned by the receiving Image Manager/Archive.**
- 160        **64. Image Manager Instances Query – An Image Manager/Archive supporting the Multiple Identity Resolution option queries another Image Manager/Archive for a list of entries representing DICOM SOP Instances.**
- 165        **65. Image Manager Instances Retrieval – An Image Manager/Archive supporting the Multiple Identity Resolution option requests and retrieves a particular SOP Instance or set of SOP Instances from another Image Manager/Archive.**

The following table shows which transactions are used in which Integration Profiles.

**Table 2.4-1. Integration Profile Transactions**

Integration Profile	SWF	PIR	PWF	RWF	CHG	CPI	PGP	KIN	ED	NM	SINR	PDI	ARI	XDS-I	MAMMO	IRWF	TCE
Transaction																	
Patient Registration [RAD-1]	X																
Placer Order [RAD-2]	X																
Filler Order [RAD-3]	X																
Procedure Scheduled [RAD-4]	X			X													
Query Modality Worklist [RAD-5]	X	X														X	
Modality Procedure Step In Progress [RAD-6]	X	X					X										
Modality Procedure Step Completed [RAD-7]	X	X		X	X		X										

IHE Technical Framework Supplement - Multiple Image Manager Archive (MIMA)

Integration Profile	SWF	PIR	PWF	RWF	CHG	CPI	PGP	KIN	ED	NM	SINR	PDI	ARI	XDS-I	MAMMO	IRWF	TCE
Transaction																	
Modality Images Stored [RAD-8]	X	X				X				X					X		
Modality Presentation State Stored [RAD-9]						X	X										
Storage Commitment [RAD-10]	X	X				X		X	X	X					X	X	
Images Availability Query [RAD-11]	X	X	X	X													
Patient Update [RAD-12]	X	X															
Procedure Update [RAD-13]	X	X		X													
Query Images [RAD-14]	X		X			X		X		X			X		X		
Query Presentation States [RAD-15]						X							X				

IHE Technical Framework Supplement - Multiple Image Manager Archive (MIMA)

Integration Profile	SWF	PIR	PWF	RWF	CHG	CPI	PGP	KIN	ED	NM	SINR	PDI	ARI	XDS-I	MAMMO	IRWF	TCE
Transaction																	
Retrieve Images [RAD-16]	X	X	X	X		X		X		X			X		X		
Retrieve Presentation States [RAD-17]						X							X				
Creator Images Stored [RAD-18]	X		X			X				X							
Creator Presentation State Stored [RAD-19]						X											
Creator Procedure Step In Progress [RAD-20]	X				X												
Creator Procedure Step Complete [RAD-21]	X				X												

IHE Technical Framework Supplement - Multiple Image Manager Archive (MIMA)

Integration Profile	SWF	PIR	PWF	RWF	CHG	CPI	PGP	KIN	ED	NM	SINR	PDI	ARI	XDS-I	MAMMO	IRWF	TCE
Transaction																	
Print Request with Presentation LUT [RAD-23]						X									X		
Report Submission [RAD-24]											X	X					
Report Issuing [RAD-25]											X	X					
Query Reports [RAD-26]		X									X	X	X				
Retrieve Reports [RAD-27]		X									X	X	X				
Structured Report Export [RAD-28]											X	X					
Key Image Note Stored [RAD-29]								X									
Query Key Image Notes [RAD-30]								X					X				

IHE Technical Framework Supplement - Multiple Image Manager Archive (MIMA)

Integration Profile	SWF	PIR	PWF	RWF	CHG	CPI	PGP	KIN	ED	NM	SINR	PDI	ARI	XDS-I	MAMMO	IRWF	TCE
Transaction																	
Retrieve Key Image Notes [RAD-31]								X					X				
Charge Posted [RAD-35]					X												
Account Management [RAD-36]					X												
Query Post-Processing Worklist [RAD-37]			X														
Workitem Claimed [RAD-38]			X	X													
Workitem PPS In-Progress [RAD-39]			X	X													
Workitem PPS Completed [RAD-40]			X	X													
Workitem Completed [RAD-41]			X	X													

IHE Technical Framework Supplement - Multiple Image Manager Archive (MIMA)

Integration Profile	SWF	PIR	PWF	RWF	CHG	CPI	PGP	KIN	ED	NM	SINR	PDI	ARI	XDS-I	MAMMO	IRWF	TCE
Transaction																	
Performed Work Status Update [RAD-42]	X		X	X	X												
Evidence Documents Stored [RAD-43]									X						X		
Query Evidence Documents [RAD-44]									X				X		X		
Retrieve Evidence Documents [RAD-45]									X				X		X		
Query Reporting Worklist [RAD-46]		X		X													
Distribute Imaging Information on Media [RAD-47]												X					
Appointment Notification [RAD-48]	X																



IHE Technical Framework Supplement - Multiple Image Manager Archive (MIMA)

Integration Profile	SWF	PIR	PWF	RWF	CHG	CPI	PGP	KIN	ED	NM	SINR	PDI	ARI	XDS-I	MAMMO	IRWF	TCE
<b>Transaction</b>																	
Instance Availability Notification [RAD-49]	X																
Store Instances [RAD-50]																	X
Store Export Selection [RAD-51]																	X
Store Additional Teaching File Information [RAD-52]																	X
Export Instances [RAD-53]																	X
Provide and Register Imaging Document Set [RAD-54]														X			
WADO Retrieve [RAD-55]														X			

IHE Technical Framework Supplement - Multiple Image Manager Archive (MIMA)

Integration Profile	SWF	PIR	PWF	RWF	CHG	CPI	PGP	KIN	ED	NM	SINR	PDI	ARI	XDS-I	MAMMO	IRWF	TCE
Transaction																	
Intentionally left blank [RAD-56]																	
Intentionally left blank [RAD-57]																	
Intentionally left blank [RAD-58]																	
Import Procedure Step In Progress [RAD-59]					X											X	
Import Procedure Step Completed [RAD-60]					X											X	
Import Objects Stored [RAD-61]																X	
<b><u>Image Manager Instances Stored [RAD-70]</u></b>	<u>X</u>	<u>X</u>															

IHE Technical Framework Supplement - Multiple Image Manager Archive (MIMA)

---

Integration Profile	SWF	PIR	PWF	RWF	CHG	CPI	PGP	KIN	ED	NM	SINR	PDI	ARI	XDS-I	MAMMO	IRWF	TCE
Transaction																	
<b><u>Image Manager Storage Commitment [RAD-71]</u></b>	X	X															
<b><u>Image Manager Instances Query [RAD-72]</u></b>	X	X															
<b><u>Image Manager Instances Retrieval [RAD-73]</u></b>	X	X															

170 *Add the following to TF vol1, section 2.5 Product Implementations*

- The Imaging Document Consumer shall be grouped with an ITI XDS Document Consumer, thereby supporting the Document Consumer's transactions for querying an XDS Registry and Repository as defined in ITI XDS.
- 175 • **The Image Manager/Archive supporting the Multiple Identity Resolution option shall be grouped with an ITI PIX Consumer thereby supporting the Consumer's transactions for querying a PIX Manager as defined in ITI PIX. It shall support the ability to cross-reference patient identifiers for the same patient by supporting the PIX Query [ITI-9] transaction, and optionally the PIX Update Notification [ITI-10] transaction.**
- 180 • The Importer Actor is generic in terms of not defining a specific transport mechanism for the Evidence Objects it imports. It may be necessary for the Importer to be grouped with additional Actors to support specific transport mechanisms. For example, to support import from PDI Media, the Importer Actor must be grouped with the Portable Media Importer
- 185 Actor.

*Modify TF vol 1, section 3 Scheduled Workflow (SWF)*

### 3 Scheduled Workflow (SWF)

190 The *Scheduled Workflow Integration Profile* establishes the continuity and integrity of basic  
departmental imaging data. It specifies a number of transactions that maintain the consistency of  
patient and ordering information as well as providing the scheduling and imaging acquisition  
procedure steps. This profile also makes it possible to determine whether images and other  
evidence objects associated with a particular performed procedure step have been stored  
195 (archived) and are available to enable subsequent workflow steps, such as reporting. It may also  
provide central coordination of the completion of processing and reporting steps as well as  
notification of appointments to the Order Placer.

### 3.1 Actors/Transactions

Figure 3.1-1 diagrams the actors involved with this profile and the transactions between actors.

NOTE: In an attempt to simplify figure 3.1-1, not all of the “optional” transactions listed in table 3.1-1 are shown in the diagram.

200

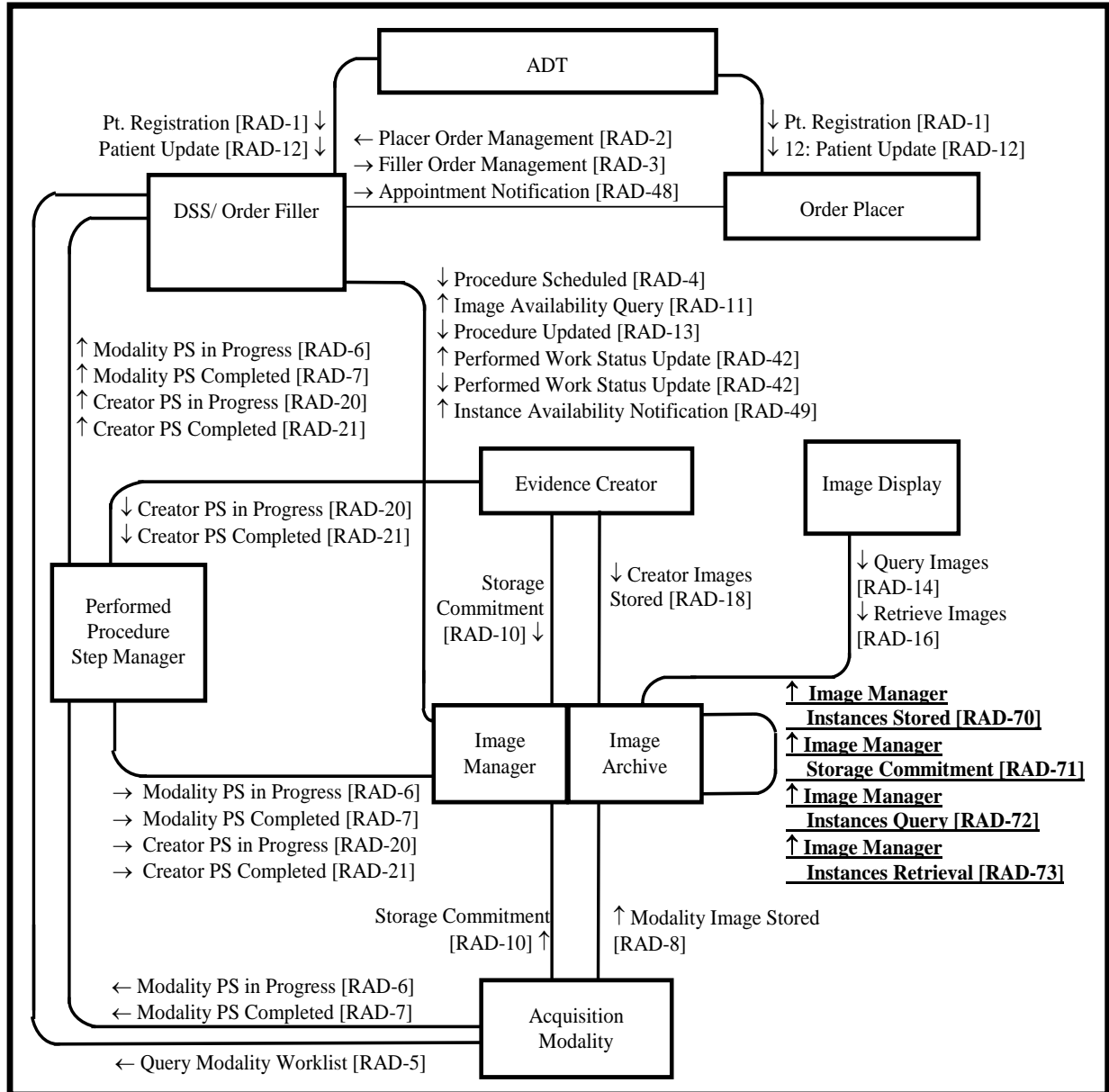

**Figure 3.1-1. Scheduled Workflow Diagram**

Table 3.1-1 lists the transactions for each actor directly involved in the Scheduled Workflow Integration Profile. In order to claim support of this Integration Profile, an implementation must

205 perform the required transactions (labeled “R”). Transactions labeled “O” are optional. A complete list of options defined by this Integration Profile that implementations may choose to support is listed in Volume 1, Section 3.2.

**Table 3.1-1. Scheduled Workflow - Actors and Transactions**

Actors	Transactions	Optionality	Vol II / III Section
Image Manager/ Image Archive	Procedure Scheduled [RAD-4]	R	4.4
	Modality Procedure Step In Progress [RAD-6]	R	4.6
	Modality Procedure Step Completed [RAD-7]	R	4.7
	Modality Images Stored [RAD-8]	R	4.8
	Images Availability Query [RAD-11]	R	4.11
	Procedure Updated [RAD-13]	R	4.13
	Query Images [RAD-14]	R	4.14
	Retrieve Images [RAD-16]	R	4.16
	Creator Images Stored [RAD-18]	R	4.18
	Creator Procedure Step in Progress [RAD-20]	R	4.20
	Creator Procedure Step Completed [RAD-21]	R	4.21
	Performed Work Status Update [RAD-42] (as the Receiver, see Note 1)	O	4.42
	Instance Availability Notification [RAD-49]	O	4.49
	<b><u>Image Manager Instances Stored [RAD-70]</u></b>	<b><u>O</u></b>	<b><u>4.70</u></b>
	<b><u>Image Manager Storage Commitment [RAD-71]</u></b>	<b><u>O</u></b>	<b><u>4.71</u></b>
<b><u>Image Manager Instances Query [RAD-72]</u></b>	<b><u>O</u></b>	<b><u>4.72</u></b>	
<b><u>Image Manager Instances Retrieval [RAD-73]</u></b>	<b><u>O</u></b>	<b><u>4.73</u></b>	

### 3.2 Scheduled Workflow Integration Profile Options

210 Options that may be selected for this Integration Profile are listed in the table 3.2-1 along with the Actors to which they apply. Dependencies between options when applicable are specified in notes.

**Table 3.2-1. Scheduled Workflow - Actors and Options**

Actor	Option	Transaction	Vol & Section
ADT Patient Registration	<i>No options defined</i>	:	-

IHE Technical Framework Supplement - Multiple Image Manager Archive (MIMA)

<b>Actor</b>	<b>Option</b>	<b>Transaction</b>	<b>Vol &amp; Section</b>
Order Placer	Departmental Appointment Notification	<b><u>Appointment Notification [RAD-48]</u></b>	RAD TF-3: 4.48
DSS/Order Filler	Image Availability	<b><u>Images Availability Query [RAD-11]</u></b>	RAD TF-2:4.11
	Departmental Appointment Notification	<b><u>Appointment Notification [RAD-48]</u></b>	RAD TF-3:4.48
	PPS Exception Management	<b><u>Modality Procedure Step Completed [RAD-7]</u></b>	RAD TF-2:4.7
	Performed Work Status Update - Receive	<b><u>Performed Work Status Update [RAD-42] (as the Receiver)</u></b>	RAD TF-3:4.42
	Availability of PPS-Referenced Instances	<b><u>Instance Availability Notification [RAD-49]</u></b>	RAD TF-3:4.49
	<b><u>Multiple Identity Resolution (see section 3.2.1)</u></b>	<b><u>Procedure Scheduled [RAD-4]</u></b>	<b><u>RAD TF-2:4.4</u></b>
<b><u>Procedure Updated [RAD-13]</u></b>		<b><u>RAD TF-2:4.13</u></b>	
Acquisition Modality	Patient Based Worklist Query (note 1)	<b><u>Query Modality Worklist [RAD-5]</u></b>	RAD TF-2:4.5
	Broad Worklist Query (note 1)	<b><u>Query Modality Worklist [RAD-5]</u></b>	RAD TF-2:4.5
	Assisted Acquisition Protocol Setting	<b><u>Modality Procedure Step In Progress [RAD-6]</u></b>	RAD TF-2:4.6
	PPS Exception Management	<b><u>Modality Procedure Step Completed [RAD-7]</u></b>	RAD TF-2:4.7
	Modality Group Case (note 2)	<b><u>Modality Procedure Step In Progress [RAD-6]</u></b>	RAD TF-2:4.6
	Billing and Material Management	<b><u>Modality Procedure Step Completed [RAD-7]</u></b>	RAD TF-2:4.7
Image Manager/ Image Archive	Availability of PPS-Referenced Instances	<b><u>Instance Availability Notification [RAD-49]</u></b>	RAD TF-3:4.49
	PPS Exception Management	<b><u>Modality Procedure Step Completed [RAD-7]</u></b>	RAD TF-2:4.7
	Performed Work Status Update - Receive	<b><u>Performed Work Status Update [RAD-42] (as the Receiver)</u></b>	RAD TF-2:4.42
	<b><u>Multiple Identity Resolution (see section 3.2.1)</u></b>	<b><u>Procedure Scheduled [RAD-4]</u></b>	<b><u>RAD TF-2:4.4</u></b>
		<b><u>Modality Procedure Step In Progress [RAD-6]</u></b>	<b><u>RAD TF-2:4.6</u></b>
		<b><u>Modality Procedure Step Completed [RAD-7]</u></b>	<b><u>RAD TF-2:4.7</u></b>
		<b><u>Creator Procedure Step in Progress [RAD-20]</u></b>	<b><u>RAD TF-2:4.20</u></b>



Actor	Option	Transaction	Vol & Section
		<b><u>Creator Procedure Step Completed [RAD-21]</u></b>	<b><u>RAD TF-2:4.21</u></b>
		<b><u>Procedure Updated [RAD-13]</u></b>	<b><u>RAD TF-2:4.13</u></b>
		<b><u>Image Manager Instances Stored [RAD-70]</u></b>	<b><u>RAD TF-3:4.70</u></b>
		<b><u>Image Manager Storage Commitment [RAD-71]</u></b>	<b><u>RAD TF-3:4.71</u></b>
		<b><u>Image Manager Instances Query [RAD-72]</u></b>	<b><u>RAD TF-3:4.72</u></b>
		<b><u>Image Manager Instances Retrieval [RAD-73]</u></b>	<b><u>RAD TF-3:4.73</u></b>
		<b><u>Modality Images Stored [RAD-8]</u></b>	<b><u>RAD TF-2:4.8</u></b>
		<b><u>Query Images [RAD-14]</u></b>	<b><u>RAD TF-2:4.14</u></b>
		<b><u>Retrieve Images [RAD-16]</u></b>	<b><u>RAD TF-2:4.16</u></b>
		<b><u>Creator Images Stored [RAD-18]</u></b>	<b><u>RAD TF-2:4.18</u></b>
Performed Procedure Step Manager	<b><u>Multiple Identity Resolution (see section 3.2.1)</u></b>	<b><u>Modality Procedure Step In Progress [RAD-6]</u></b>	<b><u>RAD TF-2:4.6</u></b>
		<b><u>Modality Procedure Step Completed [RAD-7]</u></b>	<b><u>RAD TF-2:4.7</u></b>
		<b><u>Creator Procedure Step in Progress [RAD-20]</u></b>	<b><u>RAD TF-2:4.20</u></b>
		<b><u>Creator Procedure Step Completed [RAD-21]</u></b>	<b><u>RAD TF-2:4.21</u></b>
Evidence Creator	Creator Performed Procedure Step	<b><u>Creator Procedure Step in Progress [RAD-20]</u></b>	RAD TF-2:4.20
		<b><u>Creator Procedure Step Completed [RAD-21]</u></b>	RAD TF-2:4.21
	PPS Exception Management (see note 3)	<b><u>Creator Procedure Step Completed [RAD-21]</u></b>	RAD TF-2:4.21

Note 1: At least one of these two options is required. Both may be supported.

215 Note 2: When a modality claims support for the Modality Group Case option, it is required to support all three grouping scenarios described in RAD TF-2: 4.6.4.1.2.3.4.

Note 3: An Evidence Creator claiming the PPS Exception Management Option shall also support the Creator Performed Procedure Step Option.

220 The Evidence Creator, Acquisition Modality and Image Manager/ Image Archive will likely support a variety of DICOM SOP Classes. It is expected that this level of optionality will be documented by a reference in the IHE Integration Statement (see appendix D).

### **3.2.1 Multiple Identity Resolution Option**

225 **This option handles Image Manager/Archive to Image Manager/Archive communication. It also handles Image Manager/Archives receiving input where the patient identifier can be from multiple different assigning authorities by cross-referencing identifiers. The Image Manager/Archive supports identifier cross-referencing for a particular patient regardless of which patient identifier was used to acquire the imaging data.**

**An Image Manager/Archive supporting the Multiple Identity Resolution option shall support the following:**

- 230 • **Capability to both send and receive SOP Instances, including from one Image Manager/Archive to another (RAD TF-3:4.70).**
- **Storage Commitment of SOP Instances sent from one Image Manager/Archive to another (RAD TF-3:4.71).**
- **Queries from one Image Manager/Archive to another (RAD TF-3:4.72).**
- 235 • **Retrieval of SOP Instances from one Image Manager/Archive to another (RAD TF-3:4.73).**
- **Inclusion of the Issuer of Patient ID (0010,0021), and Issuer of Accession Number Sequence (0008,0051) in all transactions between Image Manager/Archives and also in query and retrieval from other actors (RAD TF-3:J.2.4, J.2.6, J.2.7).**
- 240 • **Mandatory inclusion of the Institution Name attribute and the Institution Code Sequence in all transactions between Image Manager/Archives and also in query and retrieval from other actors (RAD TF-3:J.2.4, J.2.6, J.2.7).**
- **Configurable, per source and destination, Assigning Authority to use for the issuer of the Patient ID as the default when it is not explicitly supplied (RAD TF-3:J.2.2).**
- 245 • **Configurable, per source and destination, Assigning Authority to use for the issuer of the Accession Number as the default when it is not explicitly supplied (RAD TF-3:J.2.2).**
- **Configurable, per source and destination, Institution Name and the Institution Code Sequence to use as the default values when these are not explicitly supplied (RAD TF-3:J.2.2).**
- 250 • **Grouped with a PIX Consumer to obtain patient identifier cross-referencing information. As a PIX Consumer it shall support the PIX Query transaction. Support for the PIX Update Notification is optional (RAD TF-3:J.2.1).**
- **Inclusion of the Patient ID value corresponding to the requested or preconfigured Assigning Authority associated with other system (RAD TF-3:J.2.4, J.2.6, J.2.7).**
- 255 • **Inclusion of the Other Patient IDs Sequence with all known Patient IDs (RAD TF-3:J.2.4).**

- 260
- Source and destination specific handling of the Accession Number in received SOP Instances and when processing query and retrieval requests (RAD TF-3:J.2.4, J.2.6, and J.2.7).
  - Support for the DICOM Fuzzy Semantic Matching of Person Names option when processing query requests (RAD TF-3:J.2.6).
  - Shall be grouped with a Performed Procedure Step Manager that also supports the Multiple Identity Resolution option. The Performed Procedure Step Manager support grouped with DSS/Order Fillers shall be disabled via configuration.
- 265

A DSS/Order Filler supporting the Multiple Identity Resolution option shall support the following:

- Inclusion of the Assigning Authorities for any patient identifiers, and the Assigning Authority for the Accession Number in the Procedure Scheduled and Procedure Updated transactions (RAD TF-2:2.4.2.13).
- 270

A Performed Procedure Step Manager supporting the Multiple Identity Resolution option shall support the following:

- Inclusion of the Issuer of Patient ID (0010,0021), and Issuer of Accession Number Sequence (0008,0051) in all forwarded Performed Procedure Step messages (RAD TF-3:J.2.5.1).
- 275

An Image Manager/Archive supporting the Multiple Identity Resolution Option is not required to maintain distinct sets of patient demographic information associated with each patient identity domain.

280 The Multiple Identity Resolution option handles Image Manager/Archive to Image Manager/Archive communication. It also handles Image Manager/Archives receiving input where the patient identifier can be from multiple different assigning authorities by cross-referencing identifiers. The Image Manager/Archive shall supports identifier cross-referencing for a particular patient regardless of which patient identifier was used to acquire the imaging data, handling of Accession Numbers from multiple Assigning

285 Authorities, and handling of institution related information conveying where particular imaging data was acquired. As such the Multiple Identity Resolution option adds support for the following scenario, where Image Manager/Archives supporting single patient identifier domains are archiving imaging data to a shared Image Manager/Archive supporting the multiple patient identifier domains:

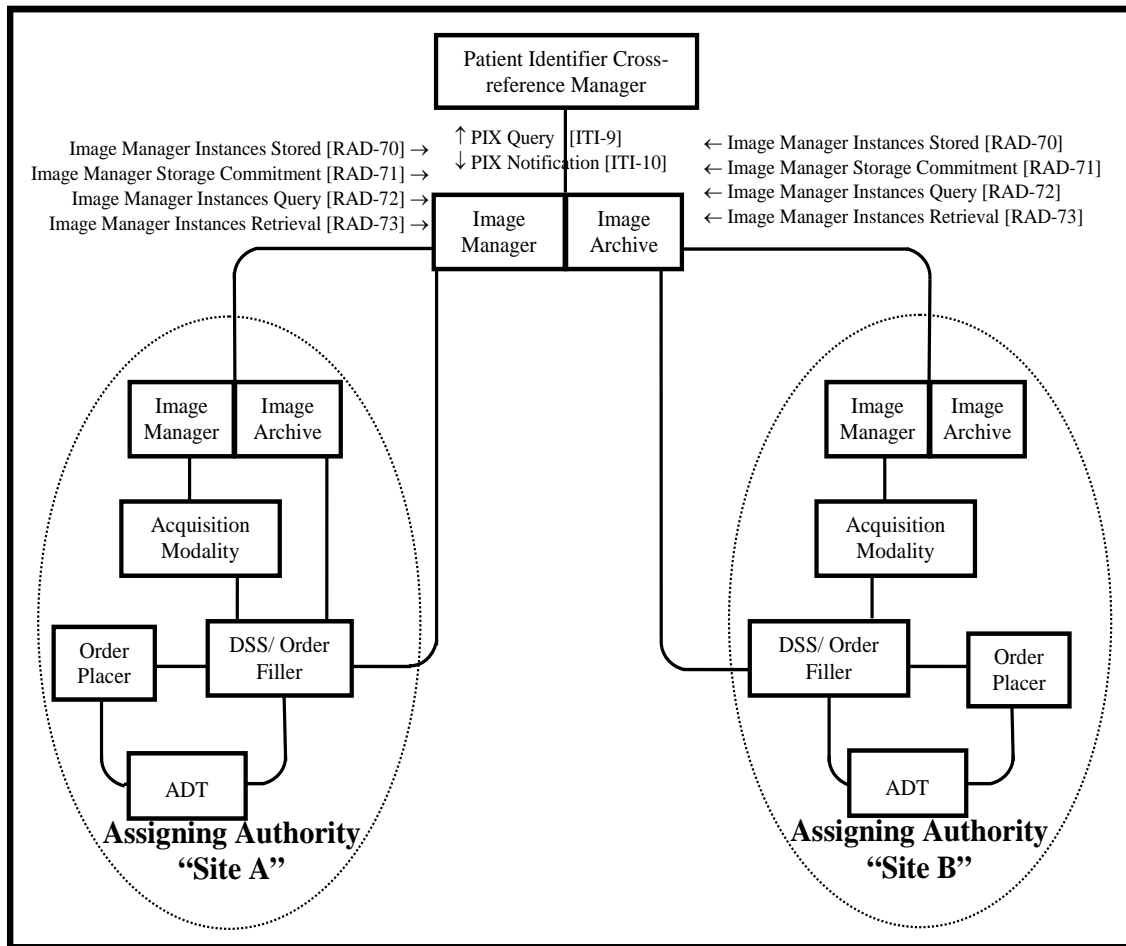

290

**Figure 3.2-3. Multiple Image Manager/Archives Supporting Multiple Patient Identifier Assigning Authorities**

**The Multiple Identity Resolution option supports the following use cases:**

295

- **Multiple Image Manager/Archives within a single Patient Identifier Domain**
- **Single Image Manager/Archive supporting multiple Patient Identifier Domains**
- **Multiple Image Manager/Archives supporting multiple Patient Identifier Domains**

**For further details regarding these use cases, and the capabilities that shall be supported by their Image Manager/Archives supporting the Multiple Identity Resolution option, refer to RAD TF-3: Appendix J: Multiple Identity Resolution Option.**

300

**Note: The Multiple Identity Resolution option defines how an Image Manager/Archive supports DSS/Order Filler, Acquisition Modality, Evidence Creator, and Image Display actors that do not convey Assigning Authority information. However, the option does assume that all Image Manager/Archives will support this option whenever there is Image Manager/Archive to Image Manager/Archive**

305 communication. Workarounds for communicating with a ‘legacy’ Image  
Manager/Archive that does not support this option are not specified. However,  
similar configurable mapping to Assigning Authority mechanisms could be  
leveraged. Of particular note is the fact that the AE Title to Assigning Authority  
310 mapping could prove useful if having to communicate with a legacy Image  
Manager/Archive that needs to support multiple patient identifier domains.  
Different AE Titles on the same system could be associated with different patient  
identifier domains.

315 Note: A useful combination of Profiles for a centralized archive product supporting  
multiple patient identifier domains is the Scheduled Workflow Multiple Identity  
Resolution option as an Image Manager plus XDS-I.b as an Imaging Document  
Source. This way the centralized archive can support communication with both  
Scheduled Workflow actors such as Image Displays, and also XDS-I.b Imaging  
Document Consumers.

320

*Modify TF voll, section 3.3 Scheduled Workflow Process Flow*

### **3.3 Scheduled Workflow Process Flow**

...

#### **3.3.7 Multiple Identity Resolution Option Process Flow**

325 **3.3.7.1 Multiple Identity Resolution Administrative and Procedure Performance**  
**Process Flow**

This case covers both inpatient and outpatient procedures. The following sequence of steps  
describes the typical process flow when a request is made to perform an imaging procedure  
on a patient.

330 In the following sequence there are two Image Managers supporting the Multiple Identity  
Resolution option. In this example of process flow one (sending) Image Manager is  
archiving imaging data to another (receiving) Image Manager/Archive.

335 In the following sequence the patient is new. The ADT is grouped with a PIX Patient  
Identity Source and so uses the PIX Patient Identity Feed [ITI-8] transaction to send the  
new patient’s information to the PIX Manager. If the patient was already known to the  
current local healthcare facility then this should not be necessary.

340 The Process Flow illustrates the two different ways that the cross-referencing of patient  
identifiers can be supported. In Figure 3.3-14 the Image Manager/Archives are supporting  
the PIX Update Notification [ITI-10] transaction to receive the cross-referencing  
information. In the alternative approach shown in Figure 3.3-15 the Image

**Manager/Archives are supporting the PIX Query [ITI-9] transaction to obtain the cross-referencing information.**

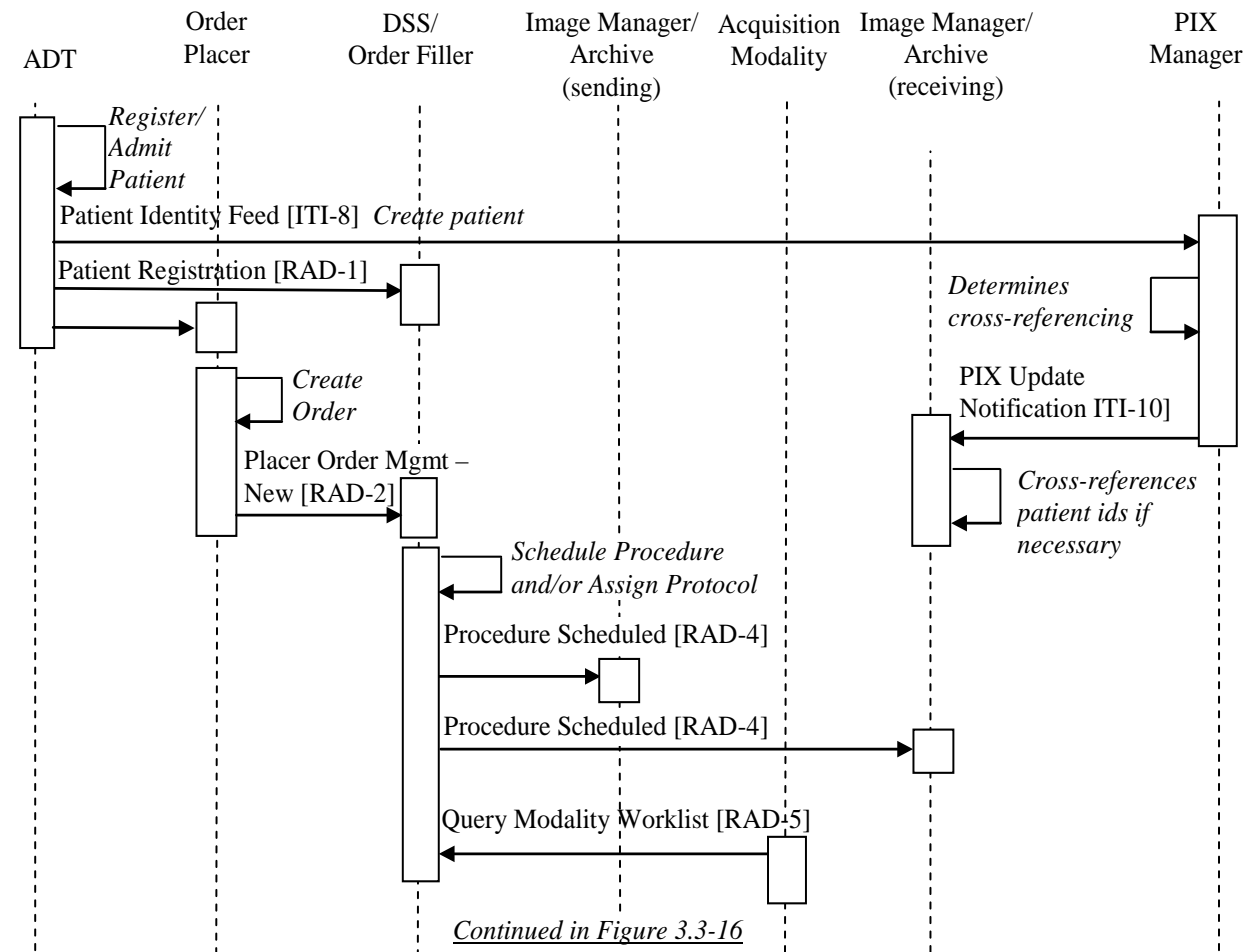

**Figure 3.3-14. Administrative Process Flow with PIX Update Notification**

345 **In Figure 3.3-14, the receiving Image Manager/Archive utilizes PIX Update Notifications even if they include patient identifiers that it does not already know of. It receives the PIX Update Notification for the new patient before actually receiving the new patient information from the Procedure Scheduled [RAD-4] but still uses this information to cross-reference patient identifiers. There is thus no need for the PIX Query [ITI-9] transaction to be used. The sending Image Manager/Archive in this example is only handling a single patient identifier Assigning Authority so it does not interact with the PIX Manager to obtain cross-referencing information.**

350

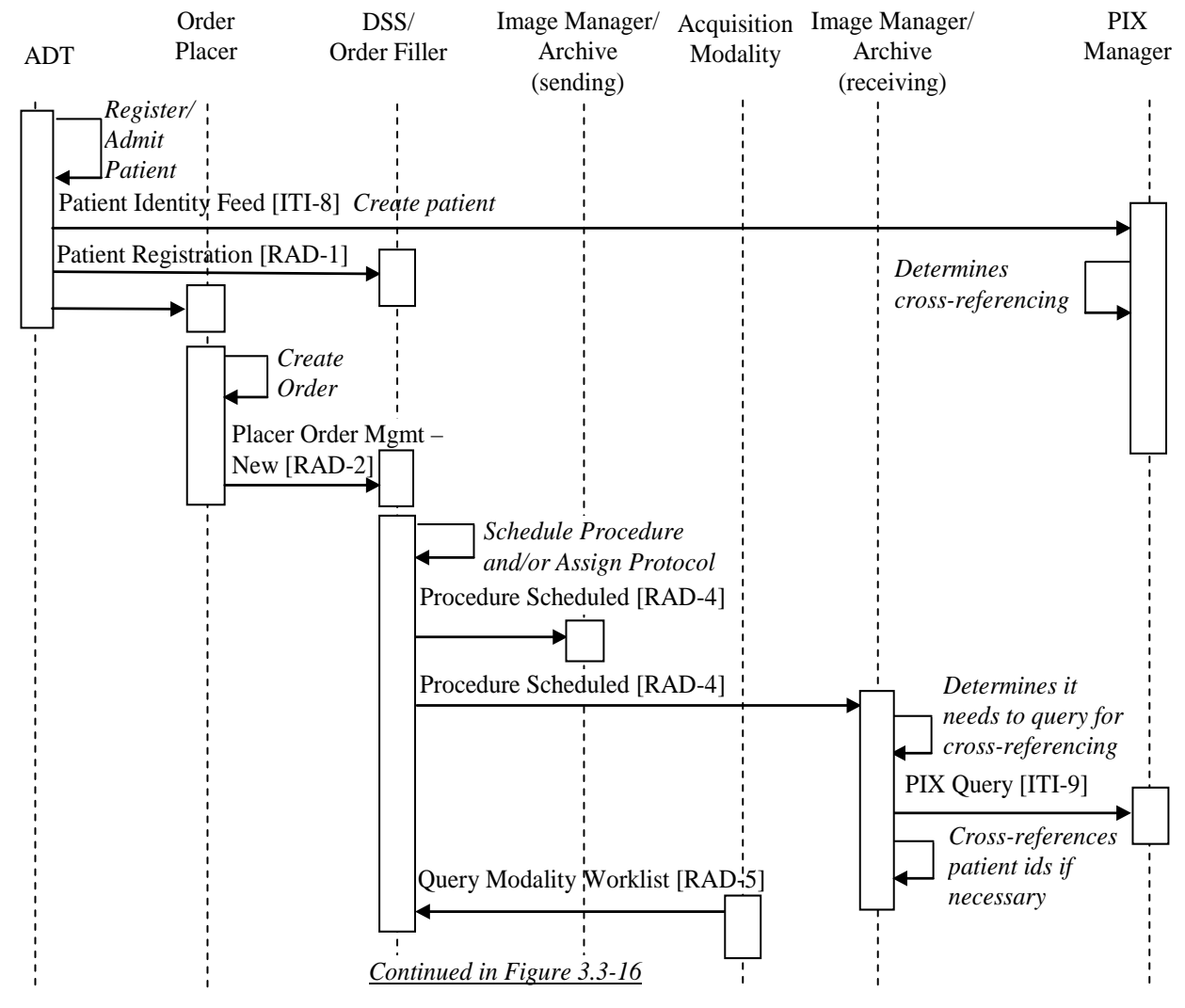

**Figure 3.3-15. Administrative Process Flow with PIX Query**

355 **In Figure 3.3-15, the receiving Image Manager/Archives utilizes the PIX Query [ITI-9] to obtain the cross-referencing of the new patient identifier to patient identifiers in any of the other patient identity domains that it handles. The sending Image Manager/Archive in this example is only handling a single patient identifier Assigning Authority so it does not interact with the PIX Manager to obtain cross-referencing information.**

360

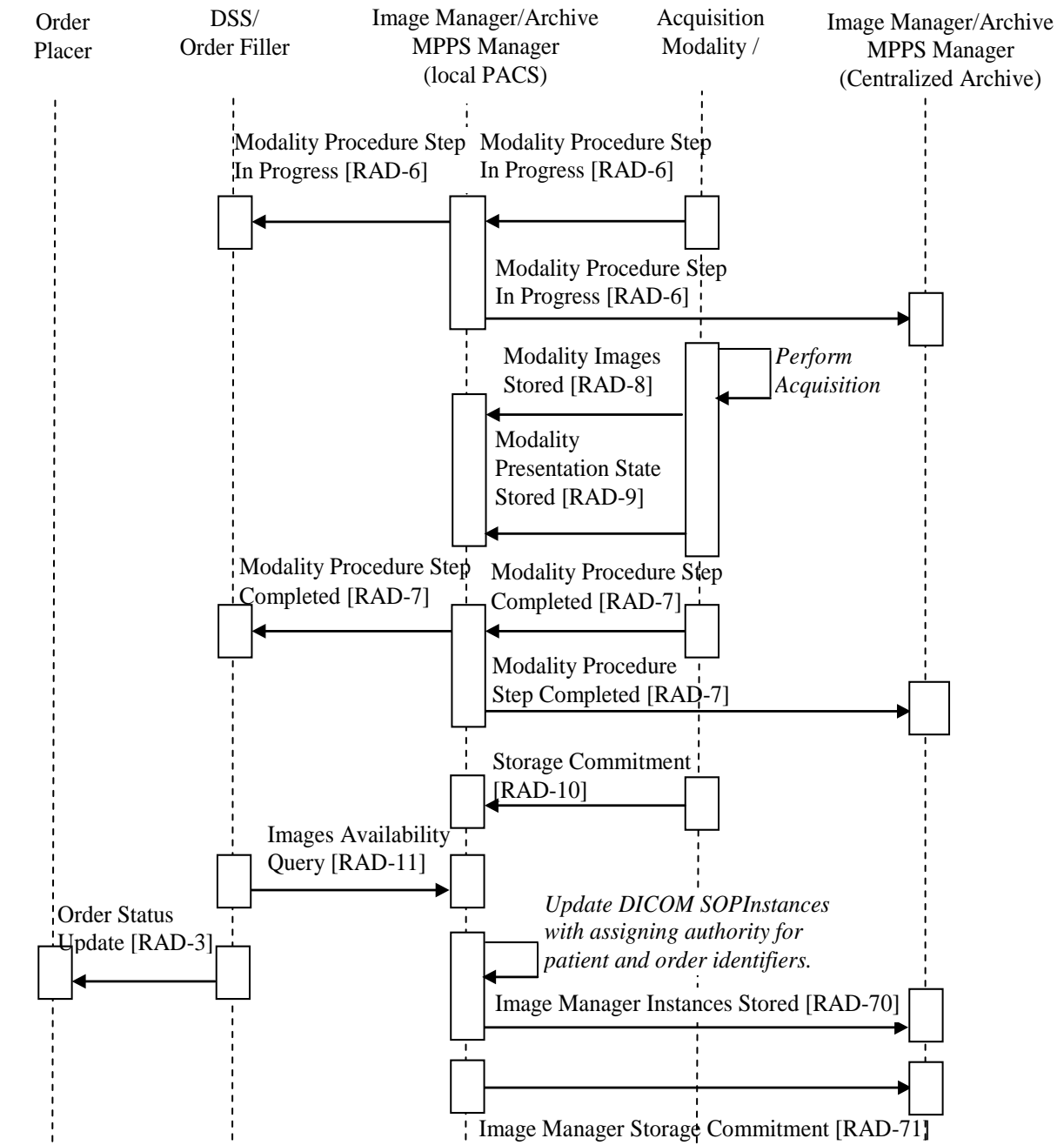

**Figure 3.3-16. Procedure Performance Process Flow**

**The following should be noted in relation to the Multi-Enterprise Archive Administrative and Procedure Performance process flow as it differs from that specified in section 3.3.1 for regular Scheduled Workflow:**

365



- **Schedule Procedure:** The Procedure Schedule transaction must go to both the sending Image Manager and the receiving Image Manager so that the receiving Image Manager can also manage the procedure workflow properly.
- 370 • **Modality Procedure Step:** The Modality Procedure Steps are communicated to both the sending Image Manager and the receiving Image Manager so that both systems receive this information and are notified of its status. Modality Procedure Step information may be essential for the receiving Image Manger to manage such workflow as specified in the Scheduled Workflow Group Case (RAD TF-2:4.6) and the Presentation of Grouped Procedures Profile (RAD TF-1:6).
- 375 • **Patient Identifier Cross-reference:** The receiving Image Manager is acting as a Patient Identifier Cross-reference Consumer so that it can identify the patient regardless of which of its possible patient identifiers is used.
- **The diagram above shows the managed creation of images. The equivalent flow applies to other Evidence Documents that the actor supports.**

### 380 **3.3.7.2 Query-Retrieval from Image Manager Supporting the Multiple Identity Resolution Option Process Flow**

385 The following sequence of steps describes typical process flow when an Image Display is query-retrieving imaging data from an Image Manager/Archive that supports the Multiple Identity Resolution option for cross-referencing patient identifiers. The Image Manager/Archive supports multiple patient identifier domains.

390 The Image Display sends a Patient Root, Patient Level or Study Root, Study Level query to the Image Manager/Archive but does not include an Issuer of Patient ID (0010,0021) value in the query request identifier. The Image Manager/Archive uses its configured mapping to determine the default patient identifier Assigning Authority associated with this particular Image Display.

395 The Image Manager/Archive finds that it has a matching patient record (or matching Studies for this patient if the Study Root Study Level query is issued). The query request identifier specifies that the Patient ID value shall be returned. If the Image Manager/Archive already had the patient identifier for the assigning authority associated with the Image Display system then it could use this in the returned query responses.

In the following example, the Image Manager/Archive has already determined the cross-referencing of patient identifiers, either through the use of the PIX Query transaction triggered through internal behavior, or by supporting the PIX Update Notification transaction.

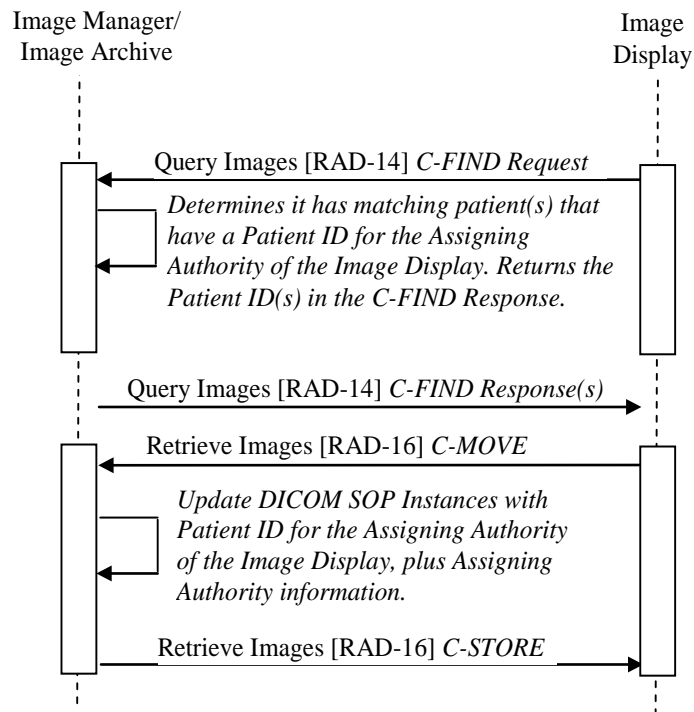

400

**Figure 3.3-17. Query-Retrieval from Image Manager Supporting the Multiple Identity Resolution Option Process Flow – Patient ID for Destination Assigning Authority is Known**

405 The following figure, 3.3-18, shows an alternative approach that the Image Manager/Archive may support. In this example, the Image Manager/Archive finds that it does not have the patient identifier for the Assigning Authority associated with the Image Display. It only has patient identifier(s) defined for other patient identity domains (for example, that were used to actually acquire imaging data for the matching patient). The Image Manager/Archive sends a PIX Query [ITI-9] to query the PIX Manager for the patient identifier for the assigning authority associated with the Image Display. In the process flow shown in Figure 3.3-18 the PIX Query [ITI-9] does return a Patient ID for this domain. This allows the Image Manager/Archive to return this Patient ID in a C-FIND Response, as shown in 3.3.-18.

410

415 The Image Display later requests the retrieval of the matching data. The Image Manager/Archive includes the patient identifier for the Assigning Authority associated with the Image Display in the exported DICOM SOP Instances along with the other additional attributes defined for this transaction. Accession Number shall be given a blank value if the Assigning Authority for the Accession Number of a SOP Instance does not match that for the Accession Number Assigning Authority associated with the Image Display.

420

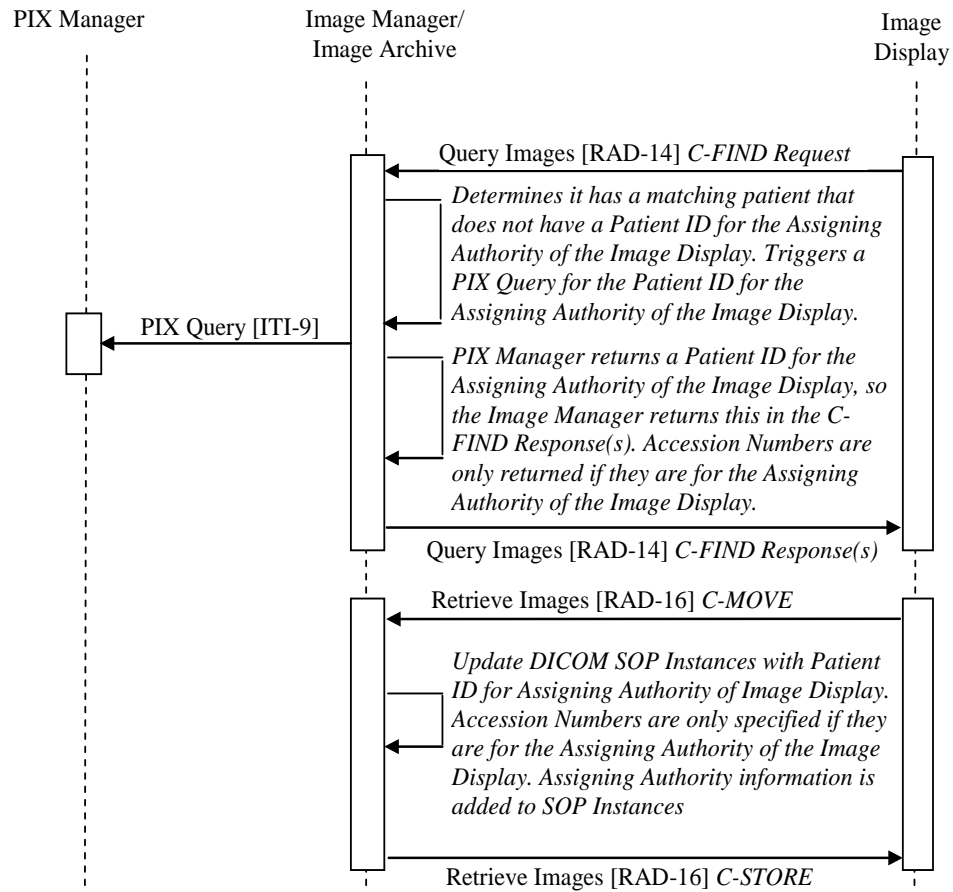

**Figure 3.3-18. Query-Retrieval from Image Manager Supporting the Multiple Identity Resolution Option Process Flow – Patient ID for Destination Assigning Authority is Obtained from PIX Manager**

425 **If the PIX Query [ITI-9] shown in Figure 3.3-18 does not return a Patient ID for the domain of the Image Display then the process flow would be as shown in Figure 3.3-19.**

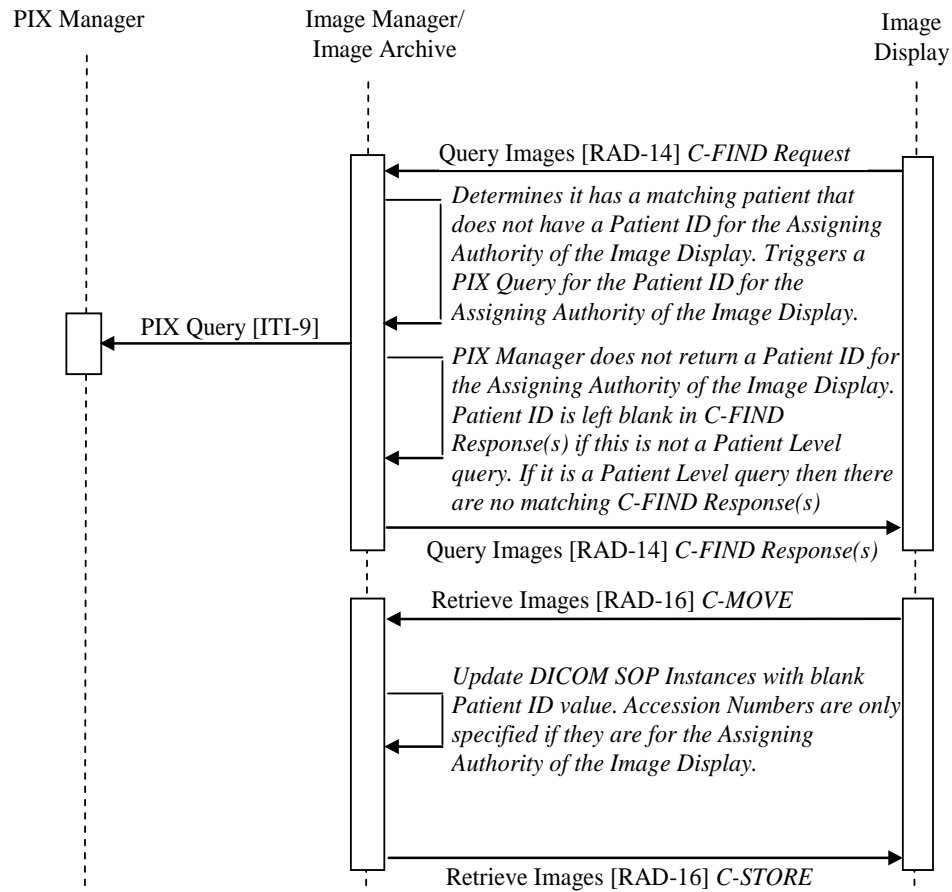

**Figure 3.3-19. Query-Retrieval from Image Manager Supporting the Multiple Identity Resolution Option Process Flow – Patient ID for Destination Assigning Authority is Not Obtained from PIX Manager**

430



445

Modify Table 4.1-1 to add the new SWF Multiple Identity Resolution option transactions. The PIR Profile currently re-lists all of the SWF transactions rather than just making it a dependency.

**Table 4.1-1. Patient Information Reconciliation - Actors and Transactions**

Actors	Transactions	Optionality	Vol II / III Section
...			
Image Manager/ Image Archive	Patient Update [RAD-12]	R	4.12
	Procedure Update [RAD-13]	R	4.13
	Modality Procedure Step In Progress [RAD-6]	R	4.6
	Modality Procedure Step Completed [RAD-7]	R	4.7
	Query Images [RAD-14]	R	4.16
	Retrieve Images [RAD-16]	R	4.16
	Images Availability Query [RAD-11]	R	4.11
	<b><u>Modality Images Stored [RAD-8]</u></b>	<b><u>O</u></b>	<b><u>4.8</u></b>
	<b><u>Creator Images Stored [RAD-18]</u></b>	<b><u>O</u></b>	<b><u>4.18</u></b>
	<b><u>Image Manager Instances Stored [RAD-70]</u></b>	<b><u>O</u></b>	<b><u>4.70</u></b>
	<b><u>Image Manager Storage Commitment [RAD-71]</u></b>	<b><u>O</u></b>	<b><u>4.71</u></b>
	<b><u>Image Manager Instances Query [RAD-72]</u></b>	<b><u>O</u></b>	<b><u>4.72</u></b>
<b><u>Image Manager Instances Retrieval [RAD-73]</u></b>	<b><u>O</u></b>	<b><u>4.73</u></b>	

## 4.2 Patient Information Reconciliation Integration Profile Options

Options that may be selected for this Integration Profile are listed in the table 4.2-1 along with the Actors to which they apply.

450

**Table 4.2-1. Patient Information Reconciliation – Actors and Options**

Actor	Option	Transaction	Vol & Section
ADT Patient Registration	<i>No options defined</i>	=	-
Order Placer	<i>No options defined</i>	=	-
DSS/Order Filler	<i>No options defined</i>	=	-
Acquisition Modality	<i>No options defined</i>	=	-
Image Manager/ Image Archive	<b><u>Multiple Identity Resolution</u></b>	<b><u>Image Manager Instances Stored [RAD-70]</u></b>	<b><u>RAD TF-3:4.70</u></b>

Actor	Option	Transaction	Vol & Section
		<u>Image Manager Storage Commitment [RAD-71]</u>	<u>RAD TF-3:4.71</u>
		<u>Image Manager Instances Query [RAD-72]</u>	<u>RAD TF-3:4.72</u>
		<u>Image Manager Instances Retrieval [RAD-73]</u>	<u>RAD TF-3:4.73</u>
		<u>Modality Images Stored [RAD-8]</u>	<u>RAD TF-2:4.8</u>
		<u>Query Images [RAD-14]</u>	<u>RAD TF-2:4.14</u>
		<u>Retrieve Images [RAD-16]</u>	<u>RAD TF-2:4.16</u>
		<u>Creator Images Stored [RAD-18]</u>	<u>RAD TF-2:4.18</u>
MPPS Manager	<i>No options defined</i>	=	-
Report Manager	<i>No options defined</i>	=	-

#### **4.2.1 Multiple Identity Resolution Option**

**An Image Manager/Archive supporting the Multiple Identity Resolution option shall support the following:**

- 455 • **The Multiple Identity Resolution option for the Scheduled Workflow Profile.**
- **Grouping with a PIX Consumer to obtain patient identifier cross-referencing information using the PIX Query transaction, and optionally the PIX Update Notification transactions (RAD TF-3:J.2.1).**

*Add a new use case for PIR when there are multiple Image Manager/Archives*

#### 460 **4.4 Use Cases**

....

#### **4.4.7 Case 7: Multiple Identity Resolution Option - Unidentified Patient Sent to Centralized Archive**

465 **In this use case the process flow requires that any unidentified patient be assigned a temporary patient identifier so that the acquired imaging data can be sent to a centralized Image Manager/Archive supporting multiple patient identifier Assigning Authorities. There is a need for immediate access to the images by a physician via the centralized archive, hence the local PACS Image Manager/Archive at “SiteA” needs to transmit the data to the centralized Image Manager/Archive before the patient has been properly**  
 470 **identified.**

**The centralized archive supports the SWF Multiple Identity Resolution option and thus can obtain the cross-referencing of patient identifiers from the PIX Manager. The PIX**

475 **Manager provides the cross-referencing of patient identifiers from each separate patient identity domain. Based on domain policies, the patient name of the unidentified patient is being assigned as “John Doe” rather than just being left as blank in the DICOM SOP Instances.**

480 **The ADT is grouped with a PIX Patient Identity Source and provides the new local patient identifier, ADOE007, for the unknown patient to the PIX Manager. In this example, the PIX Manager is not configured to send PIX Update Notifications to the centralized Image Manager/Archive. The Image Manager uses the PIX Query [ITI-9] transaction to obtain all cross-referenced patient identifiers.**

485 **Once the real patient identity is known, the ADT is responsible for reconciliation of its own records as well as informing the PIX Manager, Order Placer, and the Department System Scheduler/Order Filler. The ADT sends an HL7 A40 message in the PIX Patient Identity Feed transaction to merge the two patient records. In this example it would merge the John Doe, ADOE007, patient to Adam Smith, A000614.**

**The same HL7 A40 message is then used by the ADT in the PIR Patient Update/Merge messages sent to the Order Placer, and Department System Scheduler/Order Filler.**

490 **The Department System Scheduler/Order Filler, then sends the PIR Patient Update/Merge messages to the local Image Manager and the centralized archive Image Manager to inform them of the merge.**

495 **As an alternative to the process flow shown in this example, the centralized Image Manager/Archive could rely purely upon the PIX Update Notifications for the patient identifier cross-referencing information (as illustrated in the SWF Process Flow Figure 3.3-14).**



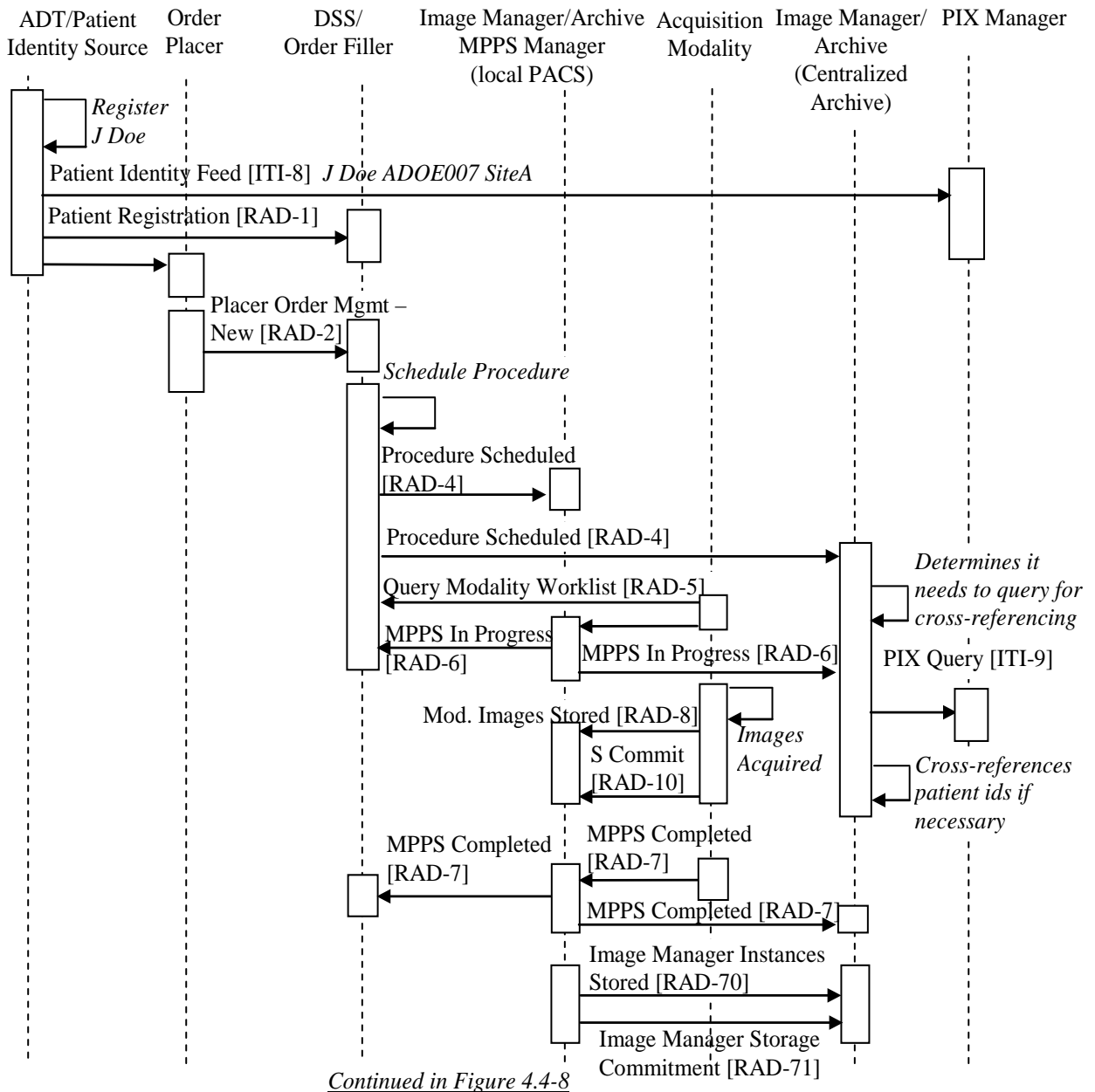

*Continued in Figure 4.4-8*

**Figure 4.4-7. Unidentified Patient Archived To Centralized Archive**

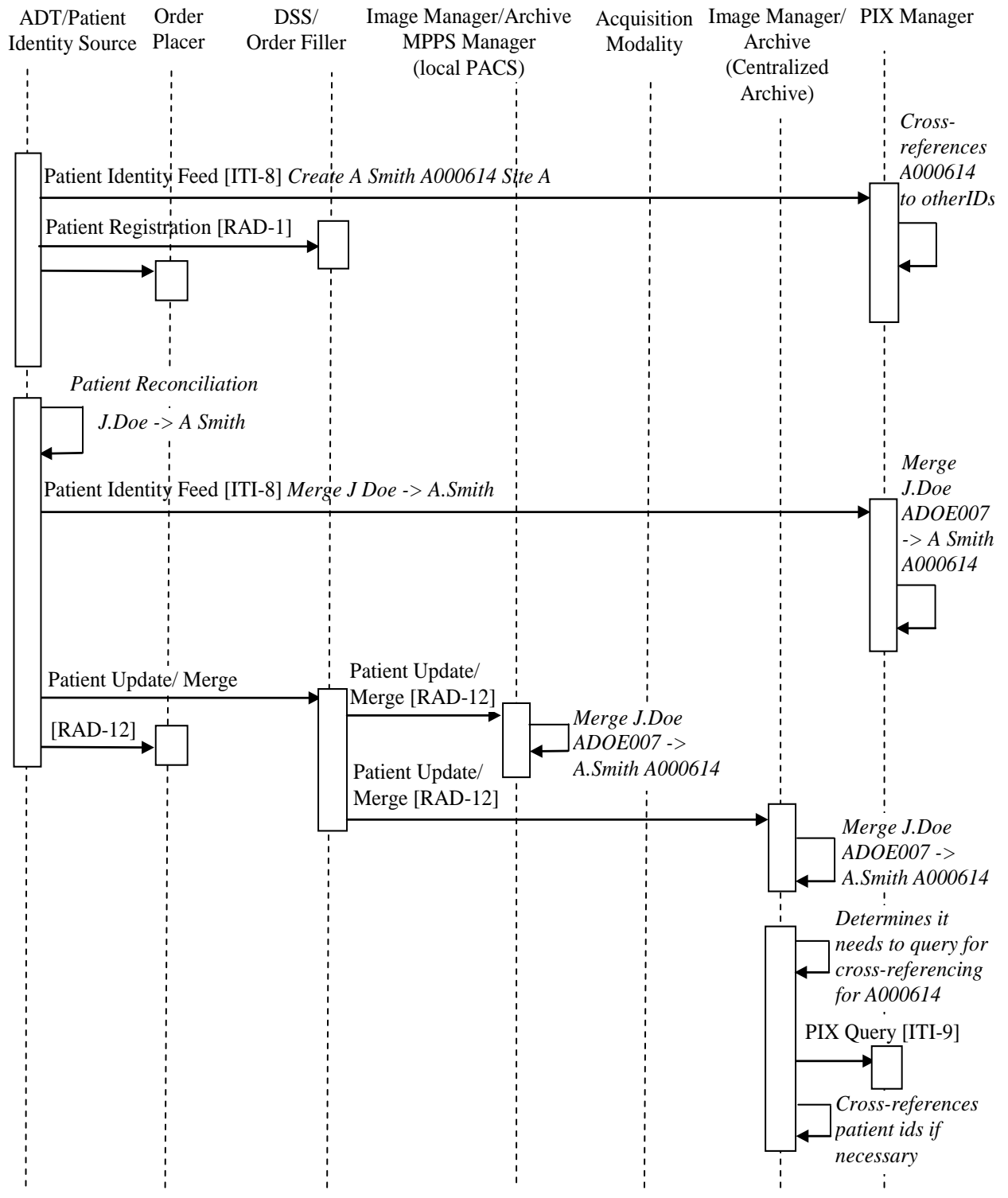

500

**Figure 4.4-8. Unidentified Patient Archived To Centralized Archive**

**Significant Transactions:**

- 505 • **If the patient, Adam Smith, already existed in the ADT system and thus already had a permanent Patient ID in the ADT system, then once the unknown patient was identified as Adam Smith, the ADT would not send the PIX Patient Identity Feed [ITI-8] for the creation of this patient. It would also not have to send the Patient Registration [RAD-1] transactions to the Order Placer and DSS/Order Filler.**
- 510 • **If a permanent Patient ID was assigned to the unidentified patient John Doe then the ADT only sends Patient Identity Feed [ITI-8] to create the John Doe patient, and the Patient Update [RAD-12] to update the Patient Name and other demographics associated with that Patient Id.**

515 **For the Multiple Identity Resolution option, the Performed Procedure Step Manager grouped with the Image Manager shall be configured to be the “active” PPS Manager. The Image Manager is thus forwarding the MPPS In Progress [RAD-6] and MPPS Completed [RAD-7] messages to the DSS/Order Filler and centralized Image Manager/Archive. For the Multiple Identity Resolution option, the Performed Procedure Step Manager grouped with the Department System Scheduler/Order Filler shall not be configured to be the “active” PPS Manager.**

## Volume 2 – Transactions

520 *Modify TF vol 2, section 4.4 Procedure Scheduled by adding the Multiple Identity Resolution option for the DSS/Order Filler and Image Manager actors.*

### 4.4 Procedure Scheduled Message

...

#### 4.4.4.1.2 Message Semantics

525 ....

##### 4.4.4.1.2.6 Multiple Identity Resolution Option

530 **A DSS/Order Filler supporting the Multiple Identity Resolution option shall support sending the Assigning Authorities for any patient identifiers and for the Accession Number sent in any ORM message used to convey necessary procedure and scheduling information. IHE already mandates the use of assigning authority (issuer) in PID-3 component 4 (RAD TF-2: Appendix D); however it is not mandatory to convey the assigning authority (issuer) of the Accession Number. The DSS/Order Filler shall specify the Assigning Authority of the Accession Number in ORC-3 and OBR-3 of an ORM message conveying the procedure and scheduling information. Table 4.4-6 defines that Placer Field 1, OBR-18, shall contain the Accession Number. OBR-18 has the ST data type so cannot convey the necessary Assigning Authority information along with the Accession Number value. The DSS/Order Filler shall specify the Assigning Authority information in the Filler Order Number elements, ORC-3 and OBR-3. It shall provide values for all components of the Filler Order Number. The second component (namespace ID) shall reference the same entity as is referenced by the third and fourth components (universal ID and universal ID type).**

535

540

**Table 4.4-9. DSS mappings of the ORC Segment for Multiple Identity Resolution Option**

<u>Element Name</u>	<u>Seq.</u>	<u>Shall Contain:</u>	<u>Notes</u>
<u>Filler Order Number</u>	<u>ORC-3</u>	<u>Filler Order Number and its assigning authority</u>	<u>Values shall be provided for all components:</u> <u>&lt;entity identifier (ST)&gt; ^</u> <u>&lt;namespace ID (IS)&gt; ^ &lt;universal ID (ST)&gt; ^ &lt;universal ID type (ID)&gt;</u>

**Table 4.4-10: DSS mappings of the OBR Segment for Multiple Identity Resolution Option**

<u>Element Name</u>	<u>Seq.</u>	<u>Shall Contain:</u>	<u>Notes</u>
<u>Filler Order Number</u>	<u>OBR-3</u>	<u>Filler Order Number and its assigning authority</u>	<u>Values shall be provided for all components:</u> <u>&lt;entity identifier (ST)&gt; ^</u>

			<u>&lt;namespace ID (IS)&gt; ^ &lt;universal ID (ST)&gt; ^ &lt;universal ID type (ID)&gt;</u>
--	--	--	---

545 **For example, a DSS/Order Filler at the Metropolitan Medical Center sends an Image Manager/Archive the following values in a Procedure Scheduled ORM message:**

**Table 4.4-11. Example Accession Number Assigning Authority in ORM Message**

<u>Element Name</u>	<u>Seq.</u>	<u>Value</u>
<u>Filler Order Number</u>	<u>ORC-3</u>	<u>35732^99MMC^1.2.mm.nnnnn.444.888888^ISO</u>
<u>Filler Order Number</u>	<u>OBR-3</u>	<u>35732^99MMC^1.2.mm.nnnnn.444.888888^ISO</u>
<u>Placer Field 1</u>	<u>OBR-18</u>	<u>A35732-1</u>

550 **Typically, the Accession Number value in OBR-18 will be the same value as the entity identifier value of the Filler Order Number in OBR-3 and ORC-3, however in this example they are not. Regardless, the same Assigning Authority is providing both of these values so the Image Manager/Archive shall still obtain the Accession Number Assigning Authority from ORC-3 or OBR-3. So in this example it would map the following values to their corresponding DICOM attributes:**

555 **Table 4.4-12. Example Mapping to DICOM Accession Number Attributes**

<u>DICOM Attribute</u>	<u>DICOM Tag</u>	<u>Value</u>
<u>Accession Number</u>	<u>(0008,0050)</u>	<u>A35732-1</u>
<u>Issuer of Accession Number Sequence</u>	<u>(0008,0051)</u>	
<u>&gt;Local Namespace Entity ID</u>	<u>(0040,0031)</u>	<u>99MMC</u>
<u>&gt;Universal Entity ID</u>	<u>(0040,0032)</u>	<u>1.2.mm.nnnnn.444.888888</u>
<u>&gt;Universal Entity ID Type</u>	<u>(0040,0033)</u>	<u>ISO</u>

**Note: The DSS/Order Filler is already required to be able to communicate with multiple Image Managers (RAD TF-2:4.4.1) so this is not a new requirement added by the Multiple Identity Resolution option.**

#### **4.4.4.2 Expected Actions**

560 ...

#### **4.4.4.2.2 Multiple Identity Resolution Option**

565 **The Image Manager supporting the Multiple Identity Resolution option shall be able to use the Patient ID Assigning Authority information and Accession Number Assigning Authority information provided by the DSS/Order Filler. See Table 4.4-9 and 4.4-10. In cases where a DSS/Order Filler provides Patient IDs with multiple different Assigning Authorities, and/or Accession Numbers with multiple different Assigning Authorities, the Image Manager shall be capable of managing this information, and maintaining the correct**

**relationship between these identifiers and their corresponding Assigning Authorities (refer to RAD TF-3: Appendix J for defined behavior).**

570 **The Image Manager shall be able to support DSS/Order Fillers that do not support this option. To do this, the Image Manager shall meet the requirements defined in Appendix J: Multiple Identity Resolution Option. Specific to this transaction, it shall support:**

- **Cross-Referencing of Patient Identifiers (RAD TF-3: J.2.1)**
- **Configurable Mapping to Default Assigning Authorities (RAD TF-3: J.2.2)**

575 • **Expected Actions when Receiving Scheduled or Updated Procedures (RAD TF-3: J.2.3)**

*Modify TF vol 2, section 4.6 Modality Procedure Step In Progress by adding the Multiple Identity Resolution option for the Image Manager actor.*

580 **4.6 Modality Procedure Step In Progress**

...

**4.6.4.1.2 Message Semantics**

....

**4.6.4.1.2.5 Multiple Identity Resolution Option**

585 **An Image Manager supporting the Multiple Identity Resolution option shall be grouped with a Performed Procedure Step Manager that also supports the Multiple Identity Resolution option. The Performed Procedure Step Manager grouped with DSS/Order Fillers shall be disabled via configuration.**

590 **The Performed Procedure Step Manager grouped with the Image Manager shall support forwarding messages to at least three other destinations, a DSS/Order Filler, a Report Manager, and another Image Manager, besides the Actor it is grouped with. It shall start issuing messages to the configured destinations immediately after it accepts the corresponding messages from the Acquisition Modality.**

595 **The forwarding of Performed Procedure Steps may need to be selective based on the particular use case. For example, the Performed Procedure Step Manager grouped with an Image Manager supporting multiple patient identifier domains may only need to forward a Performed Procedure Step to the DSS/Order Filler that is associated with the same patient identifier domain as the sending Acquisition Modality.**

600 **The Performed Procedure Step Manager shall meet the requirements defined in Appendix J: Multiple Identity Resolution Option. Specific to this transaction, it shall support:**

- **Cross-Referencing of Patient Identifiers (RAD TF-3: J.2.1)**
- **Configurable Mapping to Default Assigning Authorities (RAD TF-3: J.2.2)**
- **Message Semantics when Forwarding Performed Procedure Step Messages (RAD TF-3: J.2.5.1)**

605 **4.6.4.1.3 Expected Actions**

....

**4.6.4.1.3.1 Multiple Identity Resolution Option**

**The Image Manager shall meet the requirements defined in Appendix J: Multiple Identity Resolution Option. Specific to this transaction, it shall support:**

610

- **Cross-Referencing of Patient Identifiers (RAD TF-3: J.2.1)**
- **Configurable Mapping to Default Assigning Authorities (RAD TF-3: J.2.2)**
- **Expected Actions when Receiving Performed Procedure Steps (RAD TF-3: J.2.5.2)**



615 *Modify TF vol 2, section 4.7 Modality Procedure Step Completed/Discontinued by adding the Multiple Identity Resolution option for the Image Archive actor.*

## **4.7 Modality Procedure Step Completed/Discontinued**

...

### **4.7.4.1.2 Message Semantics**

....

#### **620 4.7.4.1.2.5 Multiple Identity Resolution Option**

**An Image Manager supporting the Multiple Identity Resolution option shall be grouped with a Performed Procedure Step Manager that also supports the Multiple Identity Resolution option. The Performed Procedure Step Manager grouped with DSS/Order Fillers shall be disabled via configuration.**

625 **The Performed Procedure Step Manager grouped with the Image Manager shall support forwarding messages to at least three other destinations, a DSS/Order Filler, a Report Manager, and another Image Manager, besides the Actor it is grouped with. It shall start issuing messages to the configured destinations immediately after it accepts the corresponding messages from the Acquisition Modality.**

630 **The Performed Procedure Step Manager shall meet the requirements defined in Appendix J: Multiple Identity Resolution Option. Specific to this transaction, it shall support:**

- **Cross-Referencing of Patient Identifiers (RAD TF-3: J.2.1)**
- **Configurable Mapping to Default Assigning Authorities (RAD TF-3: J.2.2)**
- 635 • **Message Semantics when Forwarding Performed Procedure Step Messages (RAD TF-3: J.2.5.1)**

### **4.7.4.1.3 Expected Actions**

....

#### **4.7.4.1.3.3 Multiple Identity Resolution Option**

640 **The Image Manager shall meet the requirements defined in Appendix J: Multiple Identity Resolution Option. Specific to this transaction, it shall support:**

- **Cross-Referencing of Patient Identifiers (RAD TF-3: J.2.1)**
- **Configurable Mapping to Default Assigning Authorities (RAD TF-3: J.2.2)**
- **Expected Actions when Receiving Performed Procedure Steps (RAD TF-3: J.2.5.2)**

645 *Modify TF vol 2, section 4.8 Modality Images Stored by adding the Multiple Identity Resolution option for the Image Archive actor.*

## **4.8 Modality Images Stored**

...

### **4.8.4.1.3 Expected Actions**

650 ....

#### **4.8.4.1.3.2 Multiple Identity Resolution Option**

**The Image Archive shall meet the requirements defined in Appendix J: Multiple Identity Resolution Option. Specific to this transaction, it shall support:**

- **Cross-Referencing of Patient Identifiers (RAD TF-3: J.2.1)**
- 655 • **Configurable Mapping to Default Assigning Authorities (RAD TF-3: J.2.2)**
- **Expected Actions when Receiving SOP Instances (RAD TF-3: J.2.4.1)**

660 *Modify TF vol 2, section 4.13 Procedure Update by adding the Multiple Identity Resolution option for the DSS/Order Filler and Image Manager actors.*

**4.13 Procedure Update**

...

**4.13.4.2 Message Semantics**

....

665 **4.13.4.2.1 Multiple Identity Resolution Option**

670 **A DSS/Order Filler supporting the Multiple Identity Resolution option shall support sending the Assigning Authorities for any patient identifiers and the Accession Number sent in any ORM message used to convey necessary procedure and scheduling information. IHE already mandates the use of assigning authority (issuer) in PID-3 component 4 (RAD TF-2: Appendix D); however it is not mandatory to convey the assigning authority (issuer) of the Accession Number. The DSS/Order Filler shall specify the Assigning Authority of the Accession Number in ORC-3 and OBR-3 of an ORM message conveying the procedure and scheduling information. Table 4.4-6 defines that Placer Field 1, OBR-18, shall contain the Accession Number. OBR-18 has the ST data type so cannot convey the necessary Assigning Authority information along with the Accession Number value. The DSS/Order Filler shall specify the Assigning Authority information in the Filler Order Number elements, ORC-3 and OBR-3. It shall provide values for all components of the Filler Order Number. The second component (namespace ID) shall reference the same entity as is referenced by the third and fourth components (universal ID and universal ID type).**

675

680

**Table 4.13-3. DSS mappings of the ORC Segment for Multiple Identity Resolution Option**

<u>Element Name</u>	<u>Seq.</u>	<u>Shall Contain:</u>	<u>Notes</u>
<u>Filler Order Number</u>	<u>ORC-3</u>	<u>Filler Order Number and its assigning authority</u>	<u>Values shall be provided for all components:</u> <u>&lt;entity identifier (ST)&gt; ^</u> <u>&lt;namespace ID (IS)&gt; ^ &lt;universal ID (ST)&gt; ^ &lt;universal ID type (ID)&gt;</u>

**Table 4.13-4. DSS mappings of the OBR Segment for Multiple Identity Resolution Option**

<u>Element Name</u>	<u>Seq.</u>	<u>Shall Contain:</u>	<u>Notes</u>
<u>Filler Order Number</u>	<u>OBR-3</u>	<u>Filler Order Number and its assigning authority</u>	<u>Values shall be provided for all components:</u> <u>&lt;entity identifier (ST)&gt; ^</u> <u>&lt;namespace ID (IS)&gt; ^ &lt;universal ID (ST)&gt; ^ &lt;universal ID type (ID)&gt;</u>

685 **Note: The DSS/Order Filler is already required to be able to communicate with multiple Image Managers (RAD TF-2:4.4.1) so this is not a new requirement added by the Multiple Identity Resolution option.**

#### **4.13.4.3 Expected Actions**

...

##### **4.13.4.3.1 Multiple Identity Resolution Option**

690 **The Image Manager supporting the Multiple Identity Resolution option shall be able to use the Patient ID Assigning Authority information and Accession Number Assigning Authority information provided by the DSS/Order Filler. See Table 4.13-3 and 4.13-4. In cases where a DSS/Order Filler provides Patient IDs with multiple different Assigning Authorities, and/or Accession Numbers with multiple different Assigning Authorities, the**  
695 **Image Manager shall be capable of managing this information, and maintaining the correct relationship between these identifiers and their corresponding Assigning Authorities (refer to RAD TF-3: Appendix J for defined behavior).**

700 **The Image Manager shall be able to support DSS/Order Fillers that do not support this option. To do this, the Image Manager shall meet the requirements defined in Appendix J: Multiple Identity Resolution Option. Specific to this transaction, it shall support:**

- **Cross-Referencing of Patient Identifiers (RAD TF-3: J.2.1)**
- **Configurable Mapping to Default Assigning Authorities (RAD TF-3: J.2.2)**
- **Expected Actions when Receiving Scheduled or Updated Procedures (RAD TF-3: J.2.3)**

705

*Modify TF vol2, section 4.14 Query Images to support the Multiple Identity Resolution option*

## **4.14 Query Images**

710 ...

### **4.14.4.1.3 Expected Actions**

...

#### **4.14.4.1.3.1 Multiple Identity Resolution Option**

715 **The Image Manager shall meet the requirements defined in Appendix J: Multiple Identity Resolution Option. Specific to this transaction, it shall support:**

- **Cross-Referencing of Patient Identifiers (RAD TF-3: J.2.1)**
- **Configurable Mapping to Default Assigning Authorities (RAD TF-3: J.2.2)**
- **Expected Actions when Handling Queries (RAD TF-3: J.2.6.2)**

720

*Modify TF vol 2, section 4.15 Query Presentation States to support the Multiple Identity Resolution option*

## **4.15 Query Presentation States**

...

725 **4.15.4.1.3 Expected Actions**

...

### **4.15.4.1.3.1 Multiple Identity Resolution Option**

**The Image Manager shall meet the requirements defined in Appendix J: Multiple Identity Resolution Option. Specific to this transaction, it shall support:**

730

- **Cross-Referencing of Patient Identifiers (RAD TF-3: J.2.1)**
- **Configurable Mapping to Default Assigning Authorities (RAD TF-3: J.2.2)**
- **Expected Actions when Handling Queries (RAD TF-3: J.2.6.2)**

735 *Modify TF vol2, section 4.16 Retrieve Images to support the Multiple Identity Resolution option*

## **4.16 Retrieve Images**

...

### **4.16.4.1.3 Expected Actions**

...

740 **4.16.4.1.3.3 Multiple Identity Resolution Option**

**The Image Manager shall meet the requirements defined in Appendix J: Multiple Identity Resolution Option. Specific to this transaction, it shall support:**

- **Cross-Referencing of Patient Identifiers (RAD TF-3: J.2.1)**
- **Configurable Mapping to Default Assigning Authorities (RAD TF-3: J.2.2)**
- 745 • **Expected Actions for Retrieval Requests (RAD TF-3: J.2.7)**

*Modify TF vol 2, section 4.17 Retrieve Presentation States to support the Multiple Identity Resolution option*

750 **4.17 Retrieve Presentation States**

...

**4.17.4.1.3 Expected Actions**

...

**4.17.4.1.3.1 Multiple Identity Resolution Option**

755 **The Image Manager shall meet the requirements defined in Appendix J: Multiple Identity Resolution Option. Specific to this transaction, it shall support:**

- **Cross-Referencing of Patient Identifiers (RAD TF-3: J.2.1)**
- **Configurable Mapping to Default Assigning Authorities (Section J.2.2)**
- **Expected Actions for Retrieval Requests (RAD TF-3: J.2.7)**

760



*Modify TF vol2, section 4.18 Creator Images Stored to support the Multiple Identity Resolution option*

## **4.18 Creator Images Stored**

...

### 765 **4.18.4.1.3 Expected Actions**

...

#### **4.18.4.1.3.2 Multiple Identity Resolution Option**

**The Image Archive shall meet the requirements defined in Appendix J: Multiple Identity Resolution Option. Specific to this transaction, it shall support:**

770

- **Cross-Referencing of Patient Identifiers (Section J.2.1)**
- **Configurable Mapping to Default Assigning Authorities (Section J.2.2)**
- **Expected Actions when Receiving SOP Instances (Section J.2.4.2)**

775 *Modify TF vol 2, section 4.19 Creator Presentation State Stored to support the Multiple Identity Resolution option*

## **4.19 Creator Presentation State Stored**

...

### **4.19.4.1.3 Expected Actions**

...

780 **4.19.4.1.3.1 Multiple Identity Resolution Option**

**The Image Archive shall meet the requirements defined in Appendix J: Multiple Identity Resolution Option. Specific to this transaction, it shall support:**

- **Cross-Referencing of Patient Identifiers (RAD TF-3: J.2.1)**
- **Configurable Mapping to Default Assigning Authorities (RAD TF-3: J.2.2)**
- 785 • **Expected Actions when Receiving SOP Instances (RAD TF-3: J.2.4.2)**

*Modify TF vol 2, section 4.20 Creator Procedure Step In Progress by adding the Multiple Identity Resolution option for the Image Manager actor.*

## **4.20 Creator Procedure Step In Progress**

790 ...

### **4.20.4.1.2 Message Semantics**

....

#### **4.20.4.1.2.4 Multiple Identity Resolution Option**

795 **An Image Manager supporting the Multiple Identity Resolution option shall be grouped with a Performed Procedure Step Manager that also supports the Multiple Identity Resolution option. The Performed Procedure Step Manager grouped with DSS/Order Fillers shall be disabled via configuration.**

800 **The Performed Procedure Step Manager grouped with the Image Manager shall support forwarding messages to at least three other destinations, a DSS/Order Filler, a Report Manager, and another Image Manager, besides the Actor it is grouped with. It shall start issuing messages to the configured destinations immediately after it accepts the corresponding messages from the Evidence Creator.**

805 **The forwarding of Performed Procedure Steps may need to be selective based on the particular use case. For example, the Performed Procedure Step Manager grouped with an Image Manager supporting multiple patient identifier domains may only need to forward a Performed Procedure Step to the DSS/Order Filler that is associated with the same patient identifier domain as the sending Evidence Creator.**

**The Performed Procedure Step Manager shall meet the requirements defined in Appendix J: Multiple Identity Resolution Option. Specific to this transaction, it shall support:**

- 810
- **Cross-Referencing of Patient Identifiers (RAD TF-3: J.2.1)**
  - **Configurable Mapping to Default Assigning Authorities (RAD TF-3: J.2.2)**
  - **Message Semantics when Forwarding Performed Procedure Step Messages (RAD TF-3: J.2.5.1)**

### **4.20.4.1.3 Expected Actions**

815 ....

#### **4.20.4.1.3.1 Multiple Identity Resolution Option**

**The Image Manager shall meet the requirements defined in Appendix J: Multiple Identity Resolution Option. Specific to this transaction, it shall support:**

820

- **Cross-Referencing of Patient Identifiers (RAD TF-3: J.2.1)**
- **Configurable Mapping to Default Assigning Authorities (RAD TF-3: J.2.2)**
- **Expected Actions when Receiving Performed Procedure Steps (RAD TF-3: J.2.5.2)**

*Modify TF vol 2, section 4.21 Creator Procedure Step Completed by adding the Multiple Identity Resolution option for the Image Archive actor.*

825 **4.21 Creator Procedure Step Completed**

...

**4.21.4.1.2 Message Semantics**

....

**4.21.4.1.2.5 Multiple Identity Resolution Option**

830 **An Image Manager supporting the Multiple Identity Resolution option shall be grouped with a Performed Procedure Step Manager that also supports the Multiple Identity Resolution option. The Performed Procedure Step Manager grouped with DSS/Order Fillers shall be disabled via configuration.**

835 **The Performed Procedure Step Manager grouped with the Image Manager shall support forwarding messages to at least three other destinations, a DSS/Order Filler, a Report Manager, and another Image Manager, besides the Actor it is grouped with. It shall start issuing messages to the configured destinations immediately after it accepts the corresponding messages from the Acquisition Modality.**

840 **The Performed Procedure Step Manager shall meet the requirements defined in Appendix J: Multiple Identity Resolution Option. Specific to this transaction, it shall support:**

- **Cross-Referencing of Patient Identifiers (RAD TF-3: J.2.1)**
- **Configurable Mapping to Default Assigning Authorities (RAD TF-3: J.2.2)**
- **Message Semantics when Forwarding Performed Procedure Step Messages (RAD TF-3: J.2.5.1)**
- 845 • **4.21.4.1.3 Expected Actions**

**4.21.4.1.3.1 Multiple Identity Resolution Option**

**The Image Manager shall meet the requirements defined in Appendix J: Multiple Identity Resolution Option. Specific to this transaction, it shall support:**

- **Cross-Referencing of Patient Identifiers (RAD TF-3: J.2.1)**
- 850 • **Configurable Mapping to Default Assigning Authorities (RAD TF-3: J.2.2)**
- **Expected Actions when Receiving Performed Procedure Steps (RAD TF-3: J.2.5.2)**

*Modify TF vol 2, section 4.29 Key Image Note Stored to support the Multiple Identity Resolution option.*

855 **4.29 Key Image Note Stored**

...

**4.29.4.1.3 Expected Actions**

...

**4.29.4.1.3.1 Multiple Identity Resolution Option**

860 **The Image Archive shall meet the requirements defined in Appendix J: Multiple Identity Resolution Option. Specific to this transaction, it shall support:**

- **Cross-Referencing of Patient Identifiers (RAD TF-3: J.2.1)**
- **Configurable Mapping to Default Assigning Authorities (RAD TF-3: J.2.2)**
- **Expected Actions when Receiving SOP Instances (RAD TF-3: J.2.4.2)**

865

*Modify TF vol 2, section 4.30 Query Key Image Notes to support the Multiple Identity Resolution option*

## **4.30 Query Key Image Notes**

870 ...

### **4.30.4.1.3 Expected Actions**

...

#### **4.30.4.1.3.1 Multiple Identity Resolution Option**

875 **The Image Manager shall meet the requirements defined in Appendix J: Multiple Identity Resolution Option. Specific to this transaction, it shall support:**

- **Cross-Referencing of Patient Identifiers (Section J.2.1)**
- **Configurable Mapping to Default Assigning Authorities Section J.2.2)**
- **Expected Actions when Handling Queries (Section J.2.6.2)**

880

*Modify TF vol 2, section 4.31 Retrieve Key Image Notes to support the Multiple Identity Resolution option*

## **4.31 Retrieve Key Image Notes**

...

### 885 **4.31.4.1.3 Expected Actions**

...

#### **4.31.4.1.3.1 Multiple Identity Resolution Option**

**The Image Manager shall meet the requirements defined in Appendix J: Multiple Identity Resolution Option. Specific to this transaction, it shall support:**

- 890
- **Cross-Referencing of Patient Identifiers (Section J.2.1)**
  - **Configurable Mapping to Default Assigning Authorities (Section J.2.2)**
  - **Expected Actions for Retrieval Requests (Section J.2.7)**



## Volume 3 – Transactions

895 *Add TF Vol 3, section 4.70 Image Manager Instances Stored. The Image Manager Instances Stored Transaction text is based on the Creator Images Stored (RAD-18) Transaction.*

### **4.70 Image Manager Instances Stored**

900 **This section corresponds to Transaction RAD-70 of the IHE Radiology Technical Framework. Transaction RAD-70 is used by the Image Manager actor supporting the Multiple Identity Resolution option.**

#### **4.70.1 Scope**

**In the Image Manager Instances Stored transaction, the sending Image Manager sends the DICOM SOP Instances (images, Presentation States, Key Image Notes, Evidence Documents, etc.) for a study to a receiving Image Manager.**

#### **4.70.2 Use Case Roles**

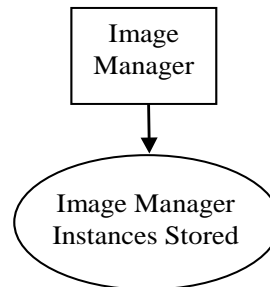

---

#### **Actor: Image Manager**

910 **Role: When acting as a sending Image Manager, transmits DICOM SOP Instances (images, Presentation States, Key Image Notes, Evidence Documents, etc.) to a receiving Image Manager. When acting as a receiving Image Manager, accepts and stores the DICOM SOP Instances that it receives.**

#### **4.70.3 Referenced Standards**

**DICOM 2009 PS 3.4: Storage Service Class.**

#### **4.70.4 Interaction Diagram**

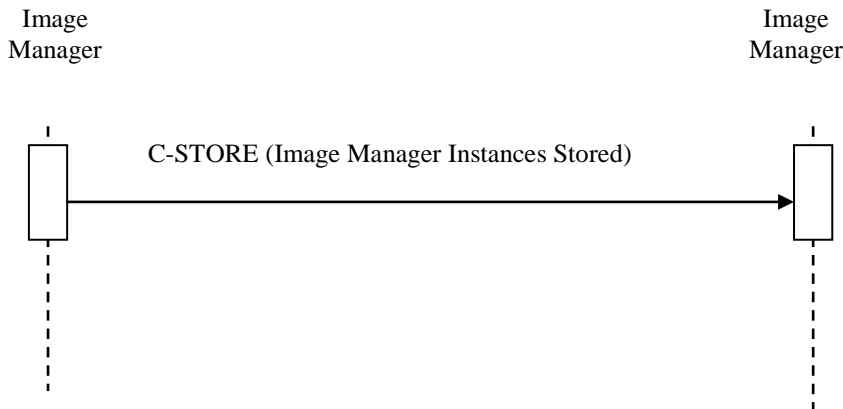

915

---

#### **4.70.4.1 Image Manager Instances Stored**

##### **4.70.4.1.1 Trigger Events**

920 **The sending Image Manager transfers SOP Instances to the receiving Image Manager sequentially within one or more DICOM associations, as the SOP Instances become available or collectively. The trigger events are dependent upon internal behavior of the sending Image Manager.**

##### **4.70.4.1.2.4 Message Semantics**

925 **The sending Image Manager uses the DICOM C-STORE message to transfer the SOP Instances. The sending Image Manager is the DICOM Storage SCU and the receiving Image Manager is the DICOM Storage SCP.**

**The sending Image Manager shall meet the requirements defined in Appendix J: Multiple Identity Resolution Option. Specific to this transaction, it shall support:**

- **Cross-Referencing of Patient Identifiers (Section J.2.1)**
- **Configurable Mapping to Default Assigning Authorities (Section J.2.2)**
- 930 • **Message Semantics when Sending SOP Instances (Section J.2.4.1)**

##### **4.70.4.1.3 Expected Actions**

**The receiving Image Manager will store the received DICOM objects.**

935 **The DICOM objects shall be stored such that they can be later retrieved (See 4.73 Image Manager Instances Retrieval) in a fashion meeting the requirements defined for a DICOM Level 2 Storage SCP (Refer to DICOM PS 3.4 B.4.1).**

**The receiving Image Manager shall meet the requirements defined in Appendix J: Multiple Identity Resolution Option. Specific to this transaction, it shall support:**

- **Cross-Referencing of Patient Identifiers (Section J.2.1)**
- **Configurable Mapping to Default Assigning Authorities (Section J.2.2)**
- **Expected Actions when Receiving SOP Instances (Section J.2.4.2)**

940

*Add TF Vol 3, section 4.71 Image Manager Storage Commitment to support Storage Commitment transactions between Image Managers.*

945 **4.71 Image Manager Storage Commitment**

**This section corresponds to Transaction RAD-71 of the IHE Radiology Technical Framework. Transaction RAD-71 is used by the Image Manager actor supporting the Multiple Identity Resolution option.**

**4.71.1 Scope**

950 **After the requesting Image Manager has sent images, Presentation States, or Key Image Notes to another, receiving Image Manager, it requests that the receiving Image Manager accept responsibility for them. The objective of this transaction is to provide a formal release of storage responsibility to the requesting Image Manager allowing it to reuse its internal resources allocated to the study.**

955 **4.71.2 Use Case Roles**

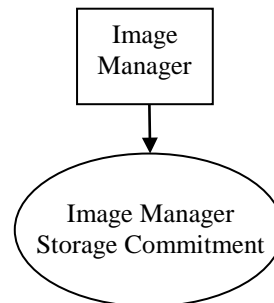

---

**Actor: Image Manager.**

960 **Role: A requesting Image Manager can make requests for storage commitment to a receiving Image Manager for the images, Presentation States, Key Image Notes, and Evidence Documents previously transmitted. A receiving Image Manager assumes responsibility for reliable storage, retrieval, and validity of images, Presentation States, Key Image Notes, and Evidence Documents.**

**4.71.3 Referenced Standards**

965 **DICOM 2009 PS 3.4: Storage Commitment Push Model SOP Class.**

**4.71.4 Interaction Diagram**

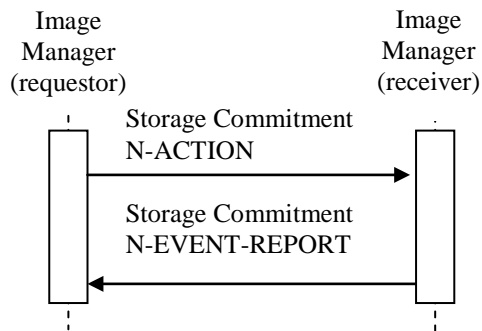

#### **4.71.4.1 Images Committed**

970 **The Storage Commitment Push Model SOP Class shall be used as reflected in the interaction diagram. The Storage Commitment Pull Model SOP Class will not be supported. Refer to the DICOM 2009 PS 3.4 for detailed descriptive semantics.**

##### **4.71.4.1.1 Trigger Events**

975 **The requesting Image Manager acts as the Storage Commitment SCU and can issue a commitment request at any time after the successful transfer of one or more SOP Instances to the receiving Image Manager, which is the Storage Commitment SCP.**

##### **4.71.4.1.2 Message Semantics**

980 **The requesting Image Manager uses the DICOM Storage Commitment SOP Class to communicate with the receiving Image Manager. The Storage Commitment AE Title used by the receiving Image Manager may or may not be the same AE Title as the one it used as a C-STORE SCP for the Image Manager Instances Stored RAD-70 transaction. The requesting Image Manager shall support this flexibility with respect to the AE Title. The N-EVENT-REPORT sent by the receiving Image Manager to communicate its storage commitment may or may not occur on the same association as the N-ACTION.**

985 **Under normal circumstances, in the event that the receiving Image Manager cannot service the storage commitment request, it shall send the reason in the "Failure Reason Attribute". In this case the requesting Image Manager shall not delete nor modify the referenced SOP instance(s).**

990 **The requesting Image Manager shall meet the requirements defined in Appendix J: Multiple Identity Resolution Option. Specific to this transaction, it shall support:**

- **Cross-Referencing of Patient Identifiers (Section J.2.1)**
- **Configurable Mapping to Default Assigning Authorities and Institution Name (Section J.2.2)**

#### **4.71.4.1.3 Expected Actions**

995 **The receiving Image Manager accepts responsibility for the safe storage of the transferred images, Presentation States, Key Image Notes, or Evidence Documents. Ownership of data transfers from the requesting Image Manager to the receiving Image Manager after a successful Storage Commitment transaction for this data has been completed. The requesting Image Manager is then free to manage its own internal resources accordingly.**

1000 **The receiving Image Manager shall meet the requirements defined in Appendix J: Multiple Identity Resolution Option. Specific to this transaction, it shall support:**

- **Cross-Referencing of Patient Identifiers (Section J.2.1)**
- **Configurable Mapping to Default Assigning Authorities and Institution Name (Section J.2.2)**

1005

*Modify TF Vol 3, by adding the Image Manager Instances Query transaction. The text is based on the Query Images [RAD-14] Transaction.*

1010 **4.72 Image Manager Instances Query**

**This section corresponds to Transaction RAD-72 of the IHE Radiology Technical Framework. Transaction RAD-72 is used by the Image Manager actor supporting the Multiple Identity Resolution option.**

**4.72.1 Scope**

1015 **A querying Image Manager actor queries a receiving Image Manager for patient, study, series and SOP Instance information.**

**4.72.2 Use Case Roles**

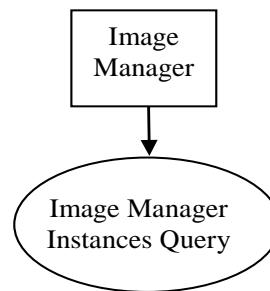

---

1020 **Actor: Image Manager**

**Role: When acting as a querying Image Manager, queries for Study, Series, and Composite SOP Instance information from a receiving Image Manager. When acting as a receiving Image Manager, responds to queries for Study, Series, and Composite SOP Instance information. The query keys for images, presentation states, structured reports, and key image notes shall be supported.**

1025

**4.72.3 Referenced Standards**

**DICOM 2009 PS 3.4: Query/Retrieve Service Class**

1030

#### **4.72.4 Interaction Diagram**

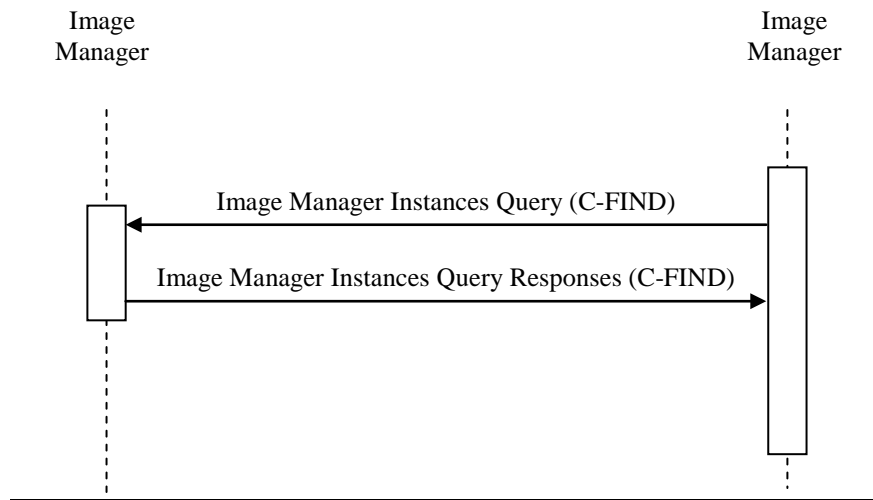

##### **4.72.4.1 Image Manager Instances Query**

1035 **The Query (Study Root – FIND and optionally Patient Root – FIND) SOP Classes shall be supported. Refer to DICOM 2009 PS 3.4 for detailed descriptive semantics.**

##### **4.72.4.1.1 Trigger Events**

**The user at the querying Image Manager wishes to view selected images or is triggered by internal Image Manager behavior.**

##### **4.72.4.1.2 Message Semantics**

1040 **The message semantics are defined by the DICOM Query/Retrieve SOP Classes.**

**A C-FIND Request from the DICOM Study Root Query/Retrieve Information Model – FIND SOP Class or optionally the DICOM Patient Root Query/Retrieve Information Model – FIND SOP Class shall be sent from the querying Image Manager to the receiving Image Manager. Hierarchical Search Method shall be supported.**

1045 **The querying Image Manager uses one or more matching keys as search criteria to obtain the list of matching entries in the receiver Image Manager at the selected level (Patient & Study/Series/Image). Based on this list of entries, the querying Image Manager may select relevant entries to be retrieved.**

1050 **The querying Image Manager shall meet the requirements defined in Appendix J: Multiple Identity Resolution Option. Specific to this transaction, they shall support:**

- **Cross-Referencing of Patient Identifiers (Section J.2.1)**
- **Configurable Mapping to Default Assigning Authorities (Section J.2.2)**
- **Message Semantics for Queries (Section J.2.6.1)**



1055 **In addition, the querying Image Manager shall support the query of Image, Presentation**  
**State, SR Instance, and Key Image Note specific keys. The matching keys and return keys**  
**that shall be supported by the querying Image Manager and the receiving Image Manager**  
**are defined in the following tables. Note that the Image Manager actor is not defined as**  
1060 **both an SCU and SCP for all of the transactions that specify these tables. The requirements**  
**for a querying Image Manager shall correspond to those of an SCU, and those for a**  
**receiving Image Manager shall correspond to those of an SCP in the following tables.**  
**However, the SCU display requirements defined in these tables do not apply to a querying**  
**Image Manager.**

- **Table 4.14-2. Image Specific Query Matching and Return Keys**
- **Table 4.15-1. Presentation State Specific Query Matching and Return Keys**
- 1065 • **Table 4.26-1. SR Instance Specific Query Matching and Return Keys**
- **Table 4.30-1. Key Image Note Instance Specific Query Matching and Return Keys**

#### **4.72.4.1.3 Expected Actions**

1070 **The receiving Image Manager receives the C-FIND request, performs the matching on the**  
**provided keys and sends the list of matching records back to the querying Image Manager**  
**via C-FIND responses. It is the responsibility of the receiving Image Manager to ensure**  
**that the patient and procedure information is current in the SOP Instances when they are**  
**retrieved. The patient and procedure information is updated through Transactions RAD-**  
**12 and RAD-13.**

1075 **The receiving Image Manager shall meet the requirements defined in Appendix J: Multiple**  
**Identity Resolution Option. Specific to this transaction, they shall support:**

- **Cross-Referencing of Patient Identifiers (Section J.2.1)**
- **Configurable Mapping to Default Assigning Authorities (Section J.2.2)**
- **Expected Actions when Handling Queries (Section J.2.6.2)**

1080 **In addition, the receiving Image Manager shall support the query of Image, Presentation**  
**State, SR Instance, and Key Image Note specific keys. The matching keys and return keys**  
**that shall be supported by the querying Image Manager and the receiving Image Manager**  
**are defined in the following tables. Note that the Image Manager actor is not defined as**  
1085 **both an SCU and SCP for all of the transactions that specify these tables. The requirements**  
**for a querying Image Manager shall correspond to those of an SCU, and those for a**  
**receiving Image Manager shall correspond to those of an SCP in the following tables.**  
**However, the SCU display requirements defined in these tables do not apply to a querying**  
**Image Manager.**

- **Table 4.14-2. Image Specific Query Matching and Return Keys**
- **Table 4.15-1. Presentation State Specific Query Matching and Return Keys**
- 1090 • **Table 4.26-1. SR Instance Specific Query Matching and Return Keys**

- **Table 4.30-1. Key Image Note Instance Specific Query Matching and Return Keys**

1095 *Modify TF Vol 3, by adding the Image Manager Instances Retrieval transaction. The text is based on the Retrieve Images [RAD-16] Transaction.*

### **4.73 Image Manager Instances Retrieval**

**This section corresponds to Transaction RAD-73 of the IHE Technical Framework. Transaction RAD-73 is used by the Image Manager actor supporting the Multiple Identity Resolution option.**

1100 **4.73.1 Scope**

**After a retrieving Image Manager actor requests image retrieval, the requested DICOM Composite SOP Instances are transferred from the receiving Image Manager to the retrieving Image Manager.**

**4.73.2 Use Case Roles**

1105

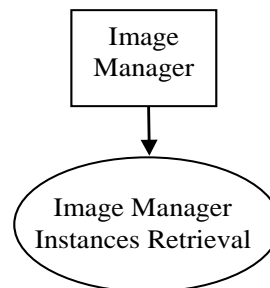

---

**Actor: Image Manager**

1110 **Role: When acting as a retrieving Image Manager, requests retrieval of Studies, Series, and Instances from a receiving Image Manager, and receives the requested Composite SOP Instances. When acting as a receiving Image Manager, responds to retrieval requests for Studies, Series, and Instances, and sends the requested SOP Instances to the retrieving Image Manager.**

**4.73.3 Referenced Standards**

**DICOM 2009 PS 3.4: Storage Service Class**

1115 **DICOM 2009 PS 3.4: Query/Retrieve Service Class**

#### **4.73.4 Interaction Diagram**

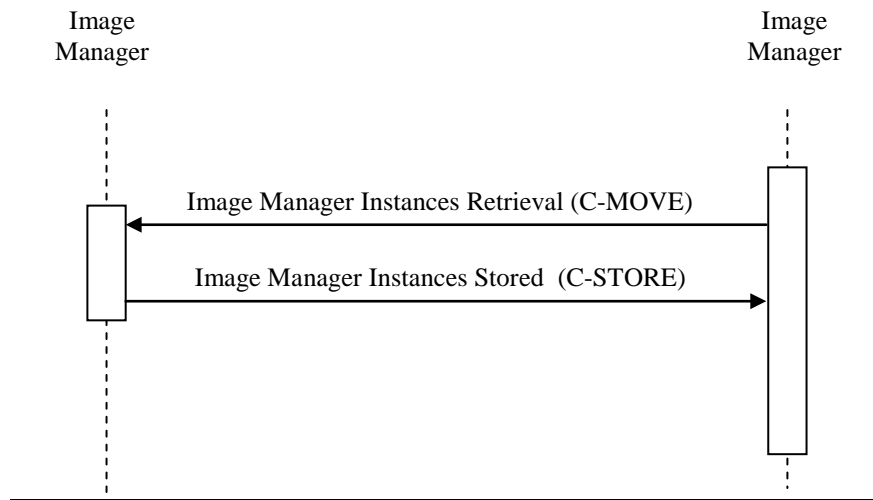

##### **4.73.4.1 Retrieve Instances**

1120 **The Retrieve (Study Root – MOVE) SOP Class shall be supported. The DICOM Image Storage SOP Classes will be supported by the receiving Image Manager as an SCU. Refer to DICOM 2009 PS 3.4, Annex C, for detailed descriptive semantics.**

##### **4.73.4.1.1 Trigger Events**

1125 **The user of a retrieving Image Manager wishes to view selected images, or a retrieving Image Manager automatically triggers the retrieval of Composite SOP Instances due to internal behavior (such as in the case where pre-fetch rules internal to a retrieving Image Manager trigger the retrieval of relevant prior SOP Instances from a receiving Image Manager).**

##### **4.73.4.1.2 Message Semantics**

1130 **The message semantics are defined by the DICOM Query/Retrieve SOP Classes and the DICOM Image Storage SOP Classes.**

**A C-MOVE Request from the DICOM Study Root Query/Retrieve Information Model – MOVE SOP Class shall be sent from the retrieving Image Manager to a receiving Image Manager.**

1135 **The retrieving Image Manager shall meet the requirements defined in Appendix J: Multiple Identity Resolution Option. Specific to this transaction, it shall support:**

- **Cross-Referencing of Patient Identifiers (Section J.2.1)**
- **Configurable Mapping to Default Assigning Authorities (Section J.2.2)**
- **Expected Actions when Receiving SOP Instances (Section J.2.4.2)**

#### **4.73.4.1.3 Expected Actions**

- 1140 **In response to a C-MOVE request, the receiving Image Manager establishes a DICOM association with the retrieving Image Manager specified using the C-MOVE Destination AE Title and uses the appropriate DICOM Storage SOP Classes to transfer the requested Composite SOP Instances. It is expected that the C-MOVE Destination retrieving Image Manager will support multiple storage SOP Classes.**
- 1145 **The receiving Image Manager shall meet the requirements defined in Appendix J: Multiple Identity Resolution Option. Specific to this transaction, it shall support:**
- **Cross-Referencing of Patient Identifiers (Section J.2.1)**
  - **Configurable Mapping to Default Assigning Authorities (Section J.2.2)**
  - **Message Semantics when Sending SOP Instances (Section J.2.4.2)**
  - 1150 • **Handling of Assigning Authorities in Retrieval Requests (Section J.2.7)**

*Add the new transactions to the TF Vol 3, Table 5.1-1 IHE Radiology transactions and resulting ATNA trigger events*

1155 **Table 5.1-2. IHE Radiology transactions and resulting ATNA trigger events**

IHE Radiology Transaction	ATNA Trigger Event(s)	Actor(s) that shall be able to record audit event
...		
<u>Image Manager Instances Stored [RAD-70]</u>	<u>Begin-storing-instances</u>	<u>Image Manager/Image Archive (sender)</u>
	<u>Instances-Stored</u>	<u>Image Manager/Image Archive (receiver)</u>
<u>Image Manager Storage Commitment [RAD-71]</u>	<u>None</u>	
<u>Image Manager Instances Query [RAD-72]</u>	<u>Query Information</u>	<u>Image Manager/Image Archive (receiver of query request)</u>
<u>Image Manager Instances Retrieval [RAD-73]</u>	<u>Instances-Stored</u>	<u>Image Manager/Image Archive (receiver of retrieval request)</u>
	<u>Study-used</u>	<u>Image Manager/Image Archive (sender of retrieval request)</u>

*Add TF Vol 3, Appendix J: Multiple Identity Resolution Option.*

## **Appendix J: Multiple Identity Resolution Option**

1160 **This appendix defines features that shall be supported by an Image Manager/Archive supporting the Multiple Identity Resolution option for the Scheduled Workflow and Patient Information Reconciliation profiles. This option handles Image Manager/Archive to Image Manager/Archive communication. It also handles Image Manager/Archives receiving input where the patient identifier can be from multiple different assigning authorities by cross-referencing identifiers. The Image Manager/Archive shall support identifier cross-referencing for a particular patient regardless of which patient identifier was used to acquire the imaging data, handling of Accession Numbers from multiple Assigning Authorities, and handling of institution related information conveying where particular imaging data was acquired.**

1165 **Section J.1 specifies the use cases for the Multiple Identity Resolution option and contains detailed examples of query and retrieve results in the various scenarios.**

**Section J.2 contains the Transaction Specifications for Image Manager/Archives that support the Multiple Identity Resolution option.**

**The requirements for a DSS/Order Filler supporting the Multiple Identity Resolution option are found in RAD TF-1:4.4.4.1.2.6 and 4.13.4.2.1.**

1175 **The requirements for a Performed Procedure Step Manager supporting the Multiple Identity Resolution option are found in**

- **RAD TF-1:4.6.4.1.2.5**
- **RAD TF-1:4.6.4.1.3.1**
- **RAD TF-1:4.7.4.1.2.5**
- 1180 • **RAD TF-1:4.7.4.1.2.3**
- **RAD TF-3:J.2.5**

### **J.1: Multiple Identity Resolution Use Cases**

**The Multiple Identity Resolution option supports the following use cases.**

#### **J.1.1: Multiple Image Manager/Archives Within a Single Patient Identity Domain**

1185 **The simplest use case is multiple Image Manager/Archives within a single patient identity domain. For example, cases where there are Image Manager/Archives for specific areas such as cardiology, or ultrasound, that are also connected to another Image Manager/Archive which serves as the long-term storage location for data from all systems.**

1190 **Imaging data can be pulled from the Image Manager/Archive acting as the long term archive by query-retrieval from another Image Manager/Archive. In addition, the long**

**term archive Image Manager/Archive could push imaging data to another Image Manager/Archive in response to some internal behavior trigger such as some automated pre-fetch functionality.**

1195

**In this use case there is no need for the cross-referencing of patient identifiers so the PIX transactions are not utilized.**

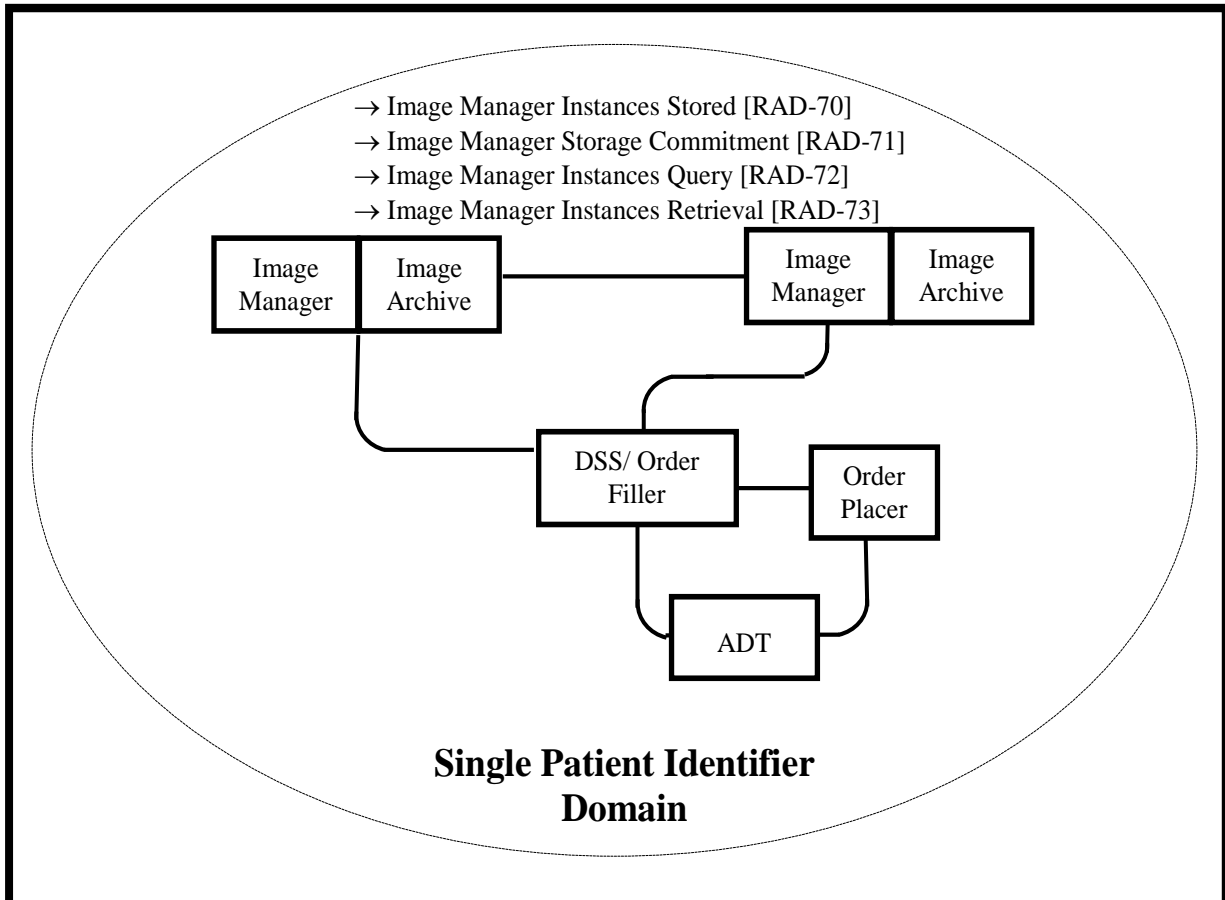

**Figure J.1-1. Multiple Image Manager/Archives Within a Single Patient Identity Domain**

**J.1.2: Single Image Manager/Archive Supporting Multiple Patient Identifier Assigning Authorities**

1200

**In this use case a single Image Manager/Archive is deployed in an environment where there are multiple patient identifier Assigning Authorities (i.e. multiple combinations of ADTs, Order Placers, and DSS/Order Fillers with different patient identifier Assigning Authorities).**

1205

**In the example illustrated below there is an Acquisition Modality and an Evidence Creator that are sending imaging data to the Image Manager/Archive. The Acquisition Modality and Evidence Creator are in different patient identity domains.**



1210 **The Image Manager/Archive supports the Multiple Identity Resolution option so that it can cross-reference the multiple patient identifiers that can exist for an individual patient. The Image Manager/Archive supports the PIX Query [ITI-9] and PIX Update Notification [ITI-10] transactions as mechanisms for obtaining and updating this cross-referencing.**

**The Image Manager/Archive that supports the Multiple Identity Resolution option supports a preconfigured assigning authority of patient identifiers associated with another system. In addition, it supports a preconfigured assigning authority of Accession Numbers associated with another system.**

1215 **An Image Display located in one of the patient identity domains query-retrieves data from the Image Manager/Archive. The Image Display does not convey Assigning Authority information in the queries and cannot necessarily utilize such information if it is included in the retrieved SOP Instances. The Image Manager/Archive thus uses the preconfigured Assigning Authority information associated with the Image Display to determine how to**  
1220 **handle the query-retrieve requests. The patient identifier cross-referencing allows the Image Manager/Archive to support query-retrieval of a patient's data regardless of which particular patient id was used to acquire it. See RAD TF-3: J.2.**

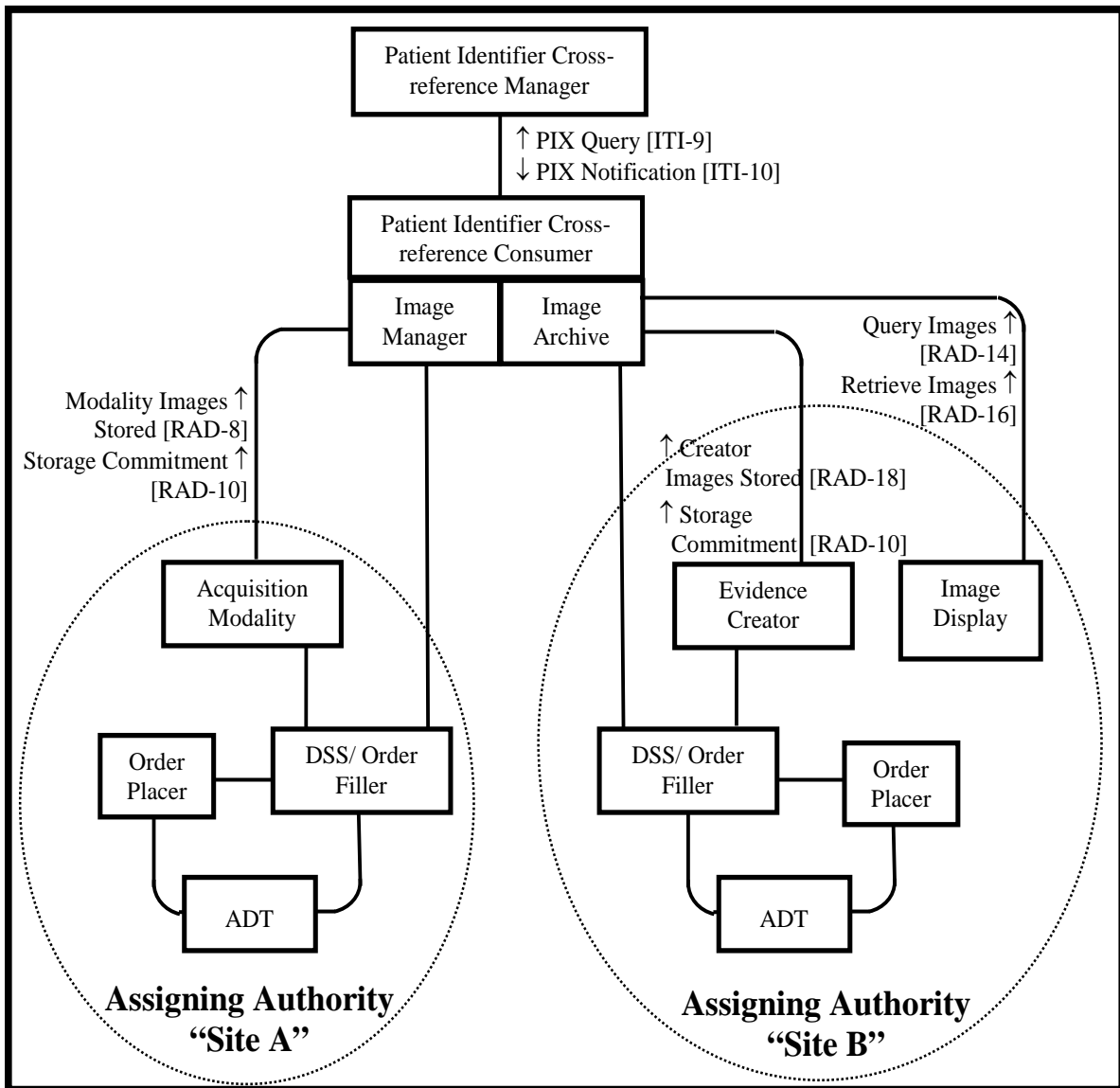

**Figure J.1-2. Single Image Manager/Archive Supporting Multiple Patient Identifier Assigning Authorities**

1225

**J.1.2.1: Query-Retrieval Examples for Single Image Manager/Archive Supporting Multiple Patient Identifier Assigning Authorities**

**This section illustrates some examples to show how query-retrieval is supported by the Image Manager/Archive supporting the Multiple Identity Resolution option described in use case J.1.2 and illustrated in Figure J.1-2.**

1230

**The following table lists the patient and Study records in the Image Manager/Archive’s database for the query-retrieve examples. The consecutive high-lighted rows are for**

**records that belong to the same patient (as indicated by the patient identifier cross-referencing provided by the PIX Manager):**

1235

Patient Records					Study			
Name		DOB	Local Identifier		Accession No	Issuer	Date	UID
Last	First		Patient ID	Issuer				
Smith	Adam	19660512	1824	Site A	12345	Site A	20100806	1.2.1
Smith	Adam	19660512	1362	Site B	12345	Site B	20100801	1.2.2
Jones	Paul	19720125	2048	Site A	35732	Site A	20100316	1.2.3
Wong	Kim	19810811	3385	Site A	42182	Site A	20100221	1.2.4
Wong	Khim	19810811	3464	Site B	57351	Site B	20100804	1.2.5
Wong	Khim	19630214	4712	Site A	62045	Site A	20100806	1.2.6
Brown	John	19720405	6418	Site A	93717	Site A	20100305	1.2.9
Black	Michael	19561121	6418	Site B	03962	Site B	20100119	1.2.10
Robert	Guy	19530217	7012	Site B	23516	Site A	20100430	1.2.11

**The Issuer values in the table above only show the Namespace ID value. The table below lists the additional values for these Assigning Authorities:**

Issuer Namespace ID	Universal ID	Universal ID Type
Site A	1.2.mm.nnnnn.111.1111	ISO
Site B	1.2.mm.nnnnn.222.2222	ISO

**The following example tables describe DICOM query-retrieve requests and the corresponding responses.**

1240

**General table structure:**

- **The Query table lists the DICOM attributes and values sent as the query request identifier in the Data Set of a C-FIND Request. The Query Root and Query Level of the query are also indicated:**
  - **Root (Patient, Study)**
  - **Level (Patient, Study, Series, Instance)**
- **The Responses table lists the DICOM attributes and values sent as the query responses in the Data Sets of the corresponding C-FIND Responses. Each query response of a separate C-FIND Response is identified by a number in the “#” column of the table.**

1245

1250

**J.1.2.1.1: Patient Level Query by Patient ID Without Specifying the Issuer**

1255 **The first query example for use case J.1.2 shows how this Image Manager/Archive handles the case where it has two different patients with the same patient identifier. The patient identifiers are from the two different assigning authorities. The Image Display from the domain using the “Site B” Assigning Authority for both patient identifiers and Accession Numbers, as illustrated in figure J.1-2, is querying the Image Manager/Archive. The user of the Image Display is searching to find demographics associated with a particular Patient ID. The Image Manager/Archive is configured to associate the Assigning Authority value of “Site B” with the querying Image Display system.**

1260 **The Image Display issues the following query request:**

Query				
Root	Level	Tag	Attribute	Value
Patient	Patient	(0010,0010)	Patient Name	
		(0010,0020)	Patient ID	6418

1265 **The Image Manager/Archive Database contains two different patients with a matching patient id value. However these two patients are from two different patient identity domains. Since the Issuer of Patient ID (0010,0021) is not present in the query, the Image Manager/Archive uses the pre-configured patient identifier Assigning Authority associated with the querying image display, “Site B”, as if it were included in the request. Thus the Image Manager/Archive only returns the single matching patient.**

**The query request identifier did not specify the Issuer of Patient ID (0010,0021). Therefore, per DICOM, this attribute shall not be included in the response, as seen in the table below:**

Responses			
#	Tag	Attribute	Value
1	(0010,0010)	Patient Name	Black^Michael
	(0010,0020)	Patient ID	6418

**J.1.2.1.2: Patient Level Query by Patient Demographics**

1270 **The following query example for use case J.1.2 shows how this Image Manager/Archive handles the case where it has a single patient with two patient identifiers from two different assigning authorities. The user is trying to find out if there are any patients in the Image Manager/Archive matching a certain name (i.e. so that they can then issue a further Study Level query if there are). The Image Manager/Archive has determined that the two patient**

1275 **identifiers belong to the same patient from the cross-referencing information provided by the PIX Manager.**

1280 **The Image Display from the domain using the “Site B” Assigning Authority for both patient identifiers and Accession Numbers, as illustrated in figure J.1-2, is querying the Image Manager/Archive. The Image Manager/Archive is configured to associate the Assigning Authority value of “Site B” with the querying Image Display system.**

**The Image Display issues the following query request:**

Query				
Root	Level	Tag	Attribute	Value
Patient	Patient	(0010,0010)	Patient Name	Smith^Adam
		(0010,0020)	Patient ID	

1285 **The Image Manager/Archive Database contains a single patient with a matching name for this demographics based query. However, it has two patient identifiers for this patient, from two different patient identifier domains. Since the Issuer of Patient ID (0010,0021) is not present in the query, the Image Manager/Archive uses the pre-configured patient identifier Assigning Authority associated with the querying Image Display, “Site B”, as if it were included in the request. Thus the Image Manager/Archive only returns the Patient ID that is that specified by the “Site B” Assigning Authority.**

1290 **The query request identifier did not specify the Issuer of Patient ID (0010,0021). Therefore, per DICOM, this attribute shall not be included in the response, as seen in the table below:**

Responses			
#	Tag	Attribute	Value
1	(0010,0010)	Patient Name	Smith^Adam
	(0010,0020)	Patient ID	1362

**J.1.2.1.3: Patient Level Query with no Matching Patient ID for the Assigning Authority**

1295 **The following query example for use case J.1.2 shows how this Image Manager/Archive handles the case where it has a matching patient for a Patient Level query but does not have a patient identifier for the requested patient identifier domain.**

1300 **The Image Display from the domain using the “Site B” Assigning Authority for both patient identifiers and Accession Numbers, as illustrated in figure J.1-2, is querying the Image Manager/Archive. The Image Manager/Archive is configured to associate the Assigning Authority value of “Site B” with the querying Image Display system.**

**The Image Display issues the following query request:**

Query				
Root	Level	Tag	Attribute	Value

Query				
Root	Level	Tag	Attribute	Value
Patient	Patient	(0010,0010)	Patient Name	Jones^Paul
		(0010,0020)	Patient ID	

1305

**In this example, the Image Manager/Archive does not actually have a patient identifier for the patient “Jones^Paul” that was assigned by Site B. Therefore, the Image Manager shall respond that there are no matches because Patient ID is a Unique Key for Patient Root, Patient Level queries.**

**J.1.2.1.4: Study Level Query with no Matching Patient ID for the Assigning Authority**

1310

**The following query example for use case J.1.2 shows how this Image Manager/Archive handles the case where it has a matching Study for a Study Level query but does not have a patient identifier for the requested patient identifier domain.**

1315

**The Image Display from the domain using the “Site B” Assigning Authority for both patient identifiers and Accession Numbers, as illustrated in figure J.1-2, is querying the Image Manager/Archive. The user of the Image Display is trying to find any Studies that belong to a patient with a certain name. The Image Manager/Archive is configured to associate the Assigning Authority value of “Site B” with the querying Image Display system.**

**The Image Display issues the following query request:**

Query				
Root	Level	Tag	Attribute	Value
Study	Study	(0010,0010)	Patient Name	Jones^Paul
		(0010,0020)	Patient ID	
		(0008,0050)	Accession Number	
		(0020,000D)	Study UID	

1320

**In this example, the Image Manager/Archive does not actually have a patient identifier for the patient “Jones^Paul” that was assigned by Site B. The preconfigured issuer is Site B but does not apply because there is no Patient ID value, so the Image Manager shall respond with a blank Patient ID. The Accession Number shall also be blank because the Assigning Authority for the Accession Number for this Study was “Site A”. Required keys can be blank in Responses, so the Image Manager can still return the matching Study record in the response:**

Responses			
#	Tag	Attribute	Value

Responses			
#	Tag	Attribute	Value
1	(0010,0010)	Patient Name	Jones^Paul
	(0010,0020)	Patient ID	
	(0008,0050)	Accession Number	
	(0020,000D)	Study UID	1.2.3

1325 **J.1.2.1.5: Study Level Query by Patient Demographics**

**The following query example for use case J.1.2 shows how this Image Manager/Archive handles the case where it has matching Studies for a Study Level query. It illustrates how the Image Manager/Archive handles a matching Study that does not have an Accession Number issued by the Assigning Authority associated with the querying system.**

1330 **The Image Display from the domain using the “Site B” Assigning Authority for both patient identifiers and Accession Numbers, as illustrated in figure J.1-2, is querying the Image Manager/Archive. The user of the Image Display is trying to find any Studies that belong to a patient with a certain name. It is sending a patient demographics based search but this time is issuing a Study Root query. The Image Manager/Archive is configured to**  
 1335 **associate the Assigning Authority value of “Site B” with the querying Image Display system for both the Patient ID and the Accession Number.**

**The Image Display issues the following query request:**

Query				
Root	Level	Tag	Attribute	Value
Study	Study	(0010,0010)	Patient Name	Smith^Adam
		(0010,0020)	Patient ID	
		(0008,0050)	Accession Number	
		(0020,000D)	Study UID	

1340 **The querying Image Display is configured to be associated with the “Site B” patient identifier Assigning Authority so the Image Manager/Archive returns the Patient ID specified by “Site B” for the matching patient. For the first matching Study response, the Accession Number shall be blank because the Assigning Authority for the Accession**  
 1345 **Number for this Study was “Site A” rather than “Site B”. The Accession Number for the second matching Study can be returned because it was assigned by “Site B”. Required keys can be blank in Responses so sending a blank Accession Number for the first matching Study is permitted.**

Responses			
#	Tag	Attribute	Value

Responses			
#	Tag	Attribute	Value
1	(0010,0010)	Patient Name	Smith^Adam
	(0010,0020)	Patient ID	1362
	(0008,0050)	Accession Number	
	(0020,000D)	Study UID	1.2.1
2	(0010,0010)	Patient Name	Smith^Adam
	(0010,0020)	Patient ID	1362
	(0008,0050)	Accession Number	12345
	(0020,000D)	Study UID	1.2.2

**J.1.2.1.6: Study Level Query by Study Characteristics**

1350 **The following query example for use case J.1.2 shows how this Image Manager/Archive handles the case where it has matching Studies for a Study Level query. It illustrates how the Image Manager/Archive handles matching Studies that are from multiple different patient identifier domains.**

1355 **The user of the Image Display from the domain using the “Site B” Assigning Authority for both patient identifiers and Accession Numbers, as illustrated in figure J.1-2, is querying the Image Manager/Archive. The user of the Image Display is trying to find any Studies that were performed between two dates. It issues a Study Root, Study Level query searching for all Studies in a specified date range. The Image Manager/Archive is configured to associate the Assigning Authority value of “Site B” with the querying Image Display system for both the Patient ID and the Accession Number.**

**The Image Display issues the following query request:**

Query				
Root	Level	Tag	Attribute	Value
Study	Study	(0010,0010)	Patient Name	
		(0010,0020)	Patient ID	
		(0008,0020)	Study Date	20100801-20100806
		(0008,0050)	Accession Number	
		(0020,000D)	Study UID	

1360 **The querying Image Display is configured to be associated with the “Site B” patient identifier Assigning Authority so the Image Manager/Archive returns the Patient ID specified by “Site B” for the matching patients. For the first matching Study response, the Accession Number shall be blank because the Assigning Authority for the Accession Number for this Study was “Site A” rather than “Site B”. For the fourth matching Study response, both the Patient ID and the Accession Number shall be blank because the**



1365 **Assigning Authority for both of these was “Site A” rather than “Site B”. Required keys can be blank in Responses.**

Responses			
#	Tag	Attribute	Value
1	(0010,0010)	Patient Name	Smith^Adam
	(0010,0020)	Patient ID	1362
	(0008,0020)	Study Date	20100806
	(0008,0050)	Accession Number	
	(0020,000D)	Study UID	1.2.1
2	(0010,0010)	Patient Name	Smith^Adam
	(0010,0020)	Patient ID	1362
	(0008,0020)	Study Date	20100806
	(0008,0050)	Accession Number	12345
	(0020,000D)	Study UID	1.2.2
3	(0010,0010)	Patient Name	Wong^Khim
	(0010,0020)	Patient ID	3464
	(0008,0020)	Study Date	20100804
	(0008,0050)	Accession Number	57351
	(0020,000D)	Study UID	1.2.5
4	(0010,0010)	Patient Name	Wong^Khim
	(0010,0020)	Patient ID	
	(0008,0020)	Study Date	20100806
	(0008,0050)	Accession Number	
	(0020,000D)	Study UID	1.2.6

**J.1.2.1.7: Study Level Query Where Patient and Accession Number Assigning Authorities Differ**

1370 **The following query example for use case J.1.2 shows how this Image Manager/Archive handles the case where it has a matching Study for a Study Level query but has different Assigning Authorities for the Patient ID and Accession Number. It illustrates how the Image Manager/Archive handles a matching Study that does not have an Accession Number issued by the Assigning Authority associated with the querying system.**

1375 **The Image Display from the domain using the “Site B” Assigning Authority for both patient identifiers and Accession Numbers, as illustrated in figure J.1-2, is querying the Image Manager/Archive. It is sending a patient demographics based Study Root query. The Image Manager/Archive is configured to associate the Assigning Authority value of “Site B” with the querying Image Display system for both the Patient ID and the Accession Number.**

1380 **The Image Display issues the following query request:**

Query				
Root	Level	Tag	Attribute	Value
Study	Study	(0010,0010)	Patient Name	Robert^Guy
		(0010,0020)	Patient ID	
		(0008,0050)	Accession Number	
		(0020,000D)	Study UID	

1385 **The querying Image Display is configured to be associated with the “Site B” patient identifier Assigning Authority so the returned Patient ID is that for Site B. The Accession Number however for the matching Study is from Assigning Authority “Site A” (perhaps as a result of an unscheduled case of Import Reconciliation Workflow). Thus the Accession Number shall be blank because the Assigning Authority for the Accession Number for this Study was “Site A”. Logically, this example is really identical to the case where the Image Manager/Archive does have a Patient ID value for the querying patient identifier domain but the matching Study does not have an Accession Number issued by the Accession Number Assigning Authority associated with the querying system.**

Responses			
#	Tag	Attribute	Value
1	(0010,0010)	Patient Name	Robert^Guy
	(0010,0020)	Patient ID	7012
	(0008,0050)	Accession Number	
	(0020,000D)	Study UID	1.2.11

1390 **J.1.2.1.8: Study Level Query Illustrating DICOM Fuzzy Semantic Matching of Person Names**

1395 **The following query example for use case J.1.2 illustrates DICOM Fuzzy Semantic Matching of Person Names. The user of the Image Display may not know the correct spelling of the patient’s name they are searching for. In addition, the Image Manager/Archive is not required to maintain separate patient demographics information for each patient domain as that would require it to support the functionality of a Patient Demographics Supplier. Instead, it shall support DICOM Fuzzy Semantic Matching so that variations in the spelling of a patient’s name in different domains can still be handled.**

1400 **The Image Display from the domain using the “Site B” Assigning Authority for both patient identifiers and Accession Numbers, as illustrated in figure J.1-2, is querying the Image Manager/Archive. It is sending a patient demographics based query. The Image Manager/Archive is configured to associate the Assigning Authority value of “Site B” with the querying Image Display system for both the Patient ID and the Accession Number.**

**The Image Display issues the following query request:**

Query				
Root	Level	Tag	Attribute	Value
Study	Study	(0010,0010)	Patient Name	Wong^Kim
		(0010,0020)	Patient ID	
		(0008,0050)	Accession Number	
		(0020,000D)	Study UID	

1405 **DICOM Fuzzy Semantic Matching of Person Names results in the name search matching both the name “Wong^Kim” and “Wong^Khim”. The querying Image Display is configured to be associated with the “Site B” patient identifier Assigning Authority so the returned Patient ID for the first matching Study response is that for Site B. For the third**

1410 **matching response the Patient ID value shall be returned blank because there is no value assigned by Site B. In addition, the Accession Number shall be blank for the first and third**

1415 **matching responses because the Assigning Authority for the Accession Number for these Studies was “Site A”. Required keys can be blank in Responses. Note that the Image Manager/Archive is not required to maintain the latest patient demographics associated with each patient identifier domain. For illustrative purposes it is doing this in the following table. However, it could just be maintaining a single name for this patient along with its cross-referenced patient identifiers. In the latter case, it would return the same patient name for all matching responses (either “Wong^Kim” or “Wong^Khim” for all responses).**

Responses			
#	Tag	Attribute	Value
1	(0010,0010)	Patient Name	Wong^Kim
	(0010,0020)	Patient ID	3464
	(0008,0050)	Accession Number	
	(0020,000D)	Study UID	1.2.4
2	(0010,0010)	Patient Name	Wong^Khim
	(0010,0020)	Patient ID	3464
	(0008,0050)	Accession Number	57351
	(0020,000D)	Study UID	1.2.5
3	(0010,0010)	Patient Name	Wong^Khim
	(0010,0020)	Patient ID	
	(0008,0050)	Accession Number	
	(0020,000D)	Study UID	1.2.6

1420 **J.1.2.1.9: Patient Root, Study Level Retrieval with Preconfigured C-MOVE Destination Accession Number Assigning Authority**

**The following retrieval example for use case J.1.2 shows how this Image Manager/Archive handles a Patient Root, Study Level Retrieval (C-MOVE) request, where the C-MOVE Destination AE has preconfigured Patient ID and Accession Number Assigning Authorities associated with it.**

1425 **The Image Display from the domain using the “Site B” Assigning Authority for both patient identifiers and Accession Numbers, as illustrated in figure J.1-2, sends a retrieval request to the Image Manager/Archive. The Image Manager/Archive is configured to associate the Assigning Authority value of “Site B” with the Image Display system for both the Patient ID and the Accession Number.**

1430 **The Image Display issues the following retrieval request:**

C-MOVE Request				
Root	Level	Tag	Attribute	Value
Patient	Study	(0010,0020)	Patient ID	1362
		(0020,000D)	Study UID	1.2.1\1.2.2

**The Image Manager/Archive finds a matching patient with the Patient ID value of “1362” for Assigning Authority “Site B”. It also finds that there are two Studies for this patient, with Study UID values matching those specified in the C-MOVE Request.**

1435 **The Image Manager/Archive also has preconfigured default patient identifier Assigning Authority and Accession Number Assigning Authority of “Site B” for the C-MOVE Destination AE. The Image Manager/Archive specifies the Patient ID value from Site B in all SOP Instances due to the preconfigured Patient ID Assigning Authority for the C-MOVE Destination AE. All known Patient ID values are returned in the Other Patient IDs Sequence (0010,1002).**

1440 **The fact that the C-MOVE Destination AE does have a preconfigured Accession Number Assigning Authority associated it means that the Accession Number in the SOP Instances sent by the Image Manager/Archive shall be blank if it is not from the preconfigured Assigning Authority. The Image Manager/Archive shall assume that the fact that there is a preconfigured Accession Number Assigning Authority means that the C-MOVE**

1445 **Destination AE cannot handle Accession Numbers from other domains. Thus the following attribute values will be present in the SOP Instances sent to the C-MOVE Destination AE:**

Retrieved SOP Instance Key Attributes			
#	Tag	Attribute	Value
1	(0010,0010)	Patient Name	Smith^Adam
	(0010,0020)	Patient ID	1362
	(0010,0021)	Issuer of Patient ID	Site B
	(0010,1002)	Other Patient IDs Sequence	
	>(0010,0020)	Patient ID	1824

Retrieved SOP Instance Key Attributes			
#	Tag	Attribute	Value
	>(0010,0021)	Issuer of Patient ID	Site A
	>(0010,0020)	Patient ID	1362
	>(0010,0021)	Issuer of Patient ID	Site B
	(0008,0050)	Accession Number	
	(0020,000D)	Study UID	1.2.1
2	(0010,0010)	Patient Name	Smith^Adam
	(0010,0020)	Patient ID	1362
	(0010,0021)	Issuer of Patient ID	Site B
	(0010,1002)	Other Patient IDs Sequence	
	>(0010,0020)	Patient ID	1824
	>(0010,0021)	Issuer of Patient ID	Site A
	>(0010,0020)	Patient ID	1362
	>(0010,0021)	Issuer of Patient ID	Site B
	(0008,0050)	Accession Number	12345
	(0008,0051)	Issuer of Accession Number Sequence	
	>(0040,0031)	Local Namespace Entity ID	Site B
	>(0040,0032)	Universal Entity ID	1.2.xx.yyyyy.222.2222
	>(0040,0033)	Universal Entity ID Type	ISO
	(0020,000D)	Study UID	1.2.2

**J.1.2.1.10: Study Root, Study Level Retrieval with no Preconfigured C-MOVE Destination Accession Number Assigning Authority**

1450 **The following retrieval example for use case J.1.2 shows how this Image Manager/Archive handles a Study Root, Study Level Retrieval (C-MOVE) request, where the C-MOVE Destination AE has a preconfigured Patient ID Assigning Authority associated with it, but does not have a preconfigured Accession Number Assigning Authority.**

1455 **The Image Display from the domain using the “Site B” Assigning Authority for both patient identifiers and Accession Numbers, as illustrated in figure J.1-2, sends a retrieval request to the Image Manager/Archive. The Image Manager/Archive is configured to associate the Assigning Authority value of “Site B” with the Image Display system for Patient IDs.**

**The Image Display issues the following retrieval request:**

C-MOVE Request				
Root	Level	Tag	Attribute	Value

C-MOVE Request				
Root	Level	Tag	Attribute	Value
Patient	Study	(0020,000D)	Study UID	1.2.3

1460 **The Image Manager/Archive finds a matching Study with the requested Study UID value of “1.2.3”. The Image Manager/Archive has a preconfigured default patient identifier Assigning Authority of “Site B” for the C-MOVE Destination AE. However, in this case it does not have a preconfigured Accession Number Assigning Authority associated with the C-MOVE Destination AE.**

1465 **The Image Manager/Archive shall specify the Patient ID value from Site B in all SOP Instances due to the preconfigured Patient ID Assigning Authority for the C-MOVE Destination AE. In this example, the patient does not have a Patient ID from the “Site B” Assigning Authority so the value shall be left blank in the retrieved SOP Instances. All known Patient ID values are returned in the Other Patient IDs Sequence (0010,1002).**

1470 **The fact that the C-MOVE Destination AE does not have a preconfigured Accession Number Assigning Authority associated with it means that the Image Manager/Archive shall assume that the C-MOVE Destination AE can handle Accession Numbers from other domains. Thus the following attribute values will be present in the SOP Instances sent to the C-MOVE Destination AE:**

Retrieved SOP Instance Key Attributes			
#	Tag	Attribute	Value
1	(0010,0010)	Patient Name	Jones^Paul
	(0010,0020)	Patient ID	
	(0010,1002)	Other Patient IDs Sequence	
	>(0010,0020)	Patient ID	2048
	>(0010,0021)	Issuer of Patient ID	Site A
	(0008,0050)	Accession Number	35732
	(0008,0051)	Issuer of Accession Number Sequence	
	>(0040,0031)	Local Namespace Entity ID	Site A
	>(0040,0032)	Universal Entity ID	1.2.mm.nnnnn.111.1111
	>(0040,0033)	Universal Entity ID Type	ISO
	(0020,000D)	Study UID	1.2.3

1475 **J.1.3: Multiple Image Manager/Archives Supporting Multiple Patient Identifier Assigning Authorities**

**In this use case multiple Image Manager/Archives are being deployed in an environment where there are multiple patient identifier Assigning Authorities. Typically this involves different combinations of ADTs, DSS/Order Fillers, and Order Placers at multiple facilities with different assigning authorities for the patient identifiers.**

1480 **In the example illustrated below there are three Image Manager/Archives. Two are local Image Manager/Archives with limited storage capabilities. They archive all imaging data to an Image Manager/Archive which is the centralized archive for all imaging data. These local Image Manager/Archives are located in different patient identifier and Accession**  
1485 **Number Assigning Authority Domains, “Site A” and “Site B”. In addition, there is an Acquisition Modality sending data directly to the centralized archive. The Acquisition Modality is from another facility with its own patient identifier and Accession Number Assigning Authority Domain, “Site C”.**

1490 **The centralized archive Image Manager/Archive utilizes the Multiple Identity Resolution option to obtain the cross-referencing of patient identifiers provided by a PIX Manager. The centralized archive Image Manager/Archive supports the PIX Query [ITI-9] and PIX Update Notification [ITI-10] transactions as mechanisms for obtaining and updating this cross-referencing. The patient identifier cross-referencing allows the centralized archive to support query-retrieval of a patient’s data regardless of which particular patient id was used to acquire it.**

1495 **The local Image Manager/Archives send the Assigning Authority for the patient identifier and the Assigning Authority for the Accession Number sent in the data archived to the centralized archive. However, the Acquisition Modality may not, as it is not mandatory for an Acquisition Modality to send these in the Modality Image Stored [RAD-8] transaction. In addition it is not mandatory for the Image Display to include Assigning Authority information in its communication with the centralized Image Manager/Archive. The centralized Image Manager/Archive that supports the Multiple Identity Resolution option supports a preconfigured Assigning Authority of patient identifiers and Assigning Authority of Accession Numbers to associate with the Acquisition Modality and Image Display systems.**

1500 **A local Image Manager/Archive can choose to only support their particular patient identifier domain rather than having to support all the domains supported by the centralized Image Manager/Archive. To be deployed in this fashion requires the following:**

- 1510 • **The local Image Manager/Archive shall only include the Patient ID and Assigning Authority of their particular patient identifier domain when sending SOP Instances to the centralized Image Manager/Archive using the Image Manager Instances Stored [RAD-70]**
- 1515 • **The local Image Manager/Archive shall always specify its particular patient identifier domain (in Issuer or Patient ID (0010,0021)) when querying for any patient level attributes using the Image Manager Instances Query [RAD-72] transaction. This means that the centralized Image Manager/Archive shall only**

**return Patient IDs belonging to the local Image Manager/Archive’s patient identifier domain.**

- **The local Image Manager/Archive shall use the PIX Query transaction to obtain a patient identifier from the particular patient identifier domain it supports if it receives a patient identifier from an unsupported domain. For example, this can occur when the local Image Manager/Archive retrieves SOP Instances from the centralized Image Manager/Archive. The SOP Instances may not contain a Patient ID from the local Image Manager/Archive’s patient identifier domain in either the Patient ID (0010,0020) or the Other Patient IDs Sequence (0010,1002).**

**Imaging data can be pulled from the Image Manager/Archive acting as the long term archive by query-retrieval from another Image Manager/Archive. In addition, the long term archive Image Manager/Archive could push imaging data to another Image Manager/Archive in response to some internal behavior trigger, such as some automated pre-fetch functionality.**

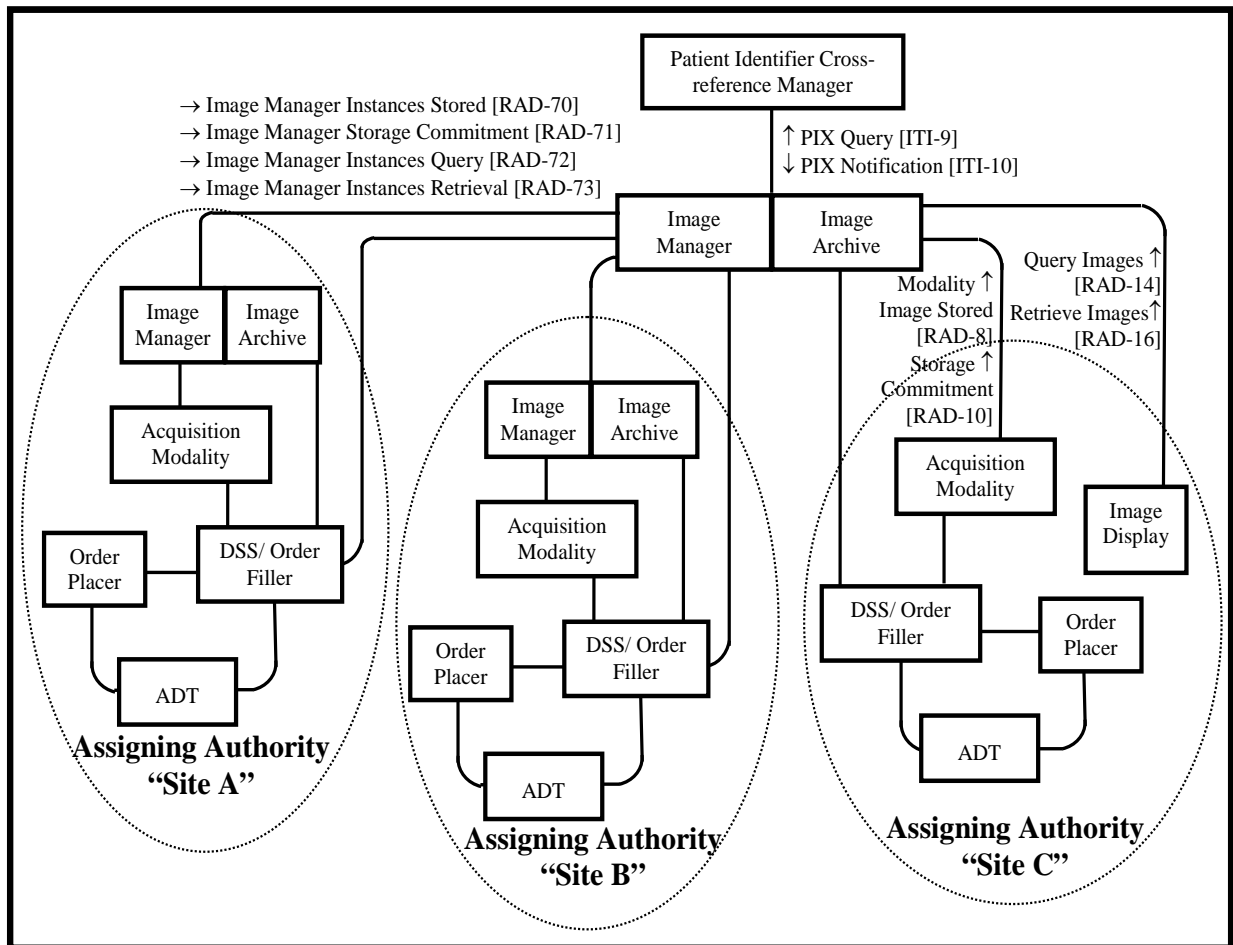

**Figure J.1-3. Multiple Image Manager/Archives Supporting Multiple Patient Identifier Assigning Authorities**



**J.1.3.1: Image Manager to Image Manager Query Examples**

1535 **This section illustrates some examples to show how query-retrieval between Image Manager/Archives supporting the Multiple Identity Resolution option described in use case J.1.3 and shown in Figure J.1-3. The Image Display query-retrieve behavior for Figure J.1-3 will be identical to the previous examples for the scenario given in Figure J.1-2 so no additional Image Display to Image Manager/Archive query-retrieve examples are given.**

1540 **The following table lists the patient and Study records in the Image Manager/Archive’s database for the query-retrieve examples. The consecutive high-lighted rows are for records that belong to the same patient (as indicated by the patient identifier cross-referencing provided by the PIX Manager):**

Patient Records					Study		
Name		DOB	Local Identifier		Accession No	Issuer	UID
Last	First		Patient ID	Issuer			
Smith	Adam	19660512	1824	Site A	12345	Site A	1.2.1
Smith	Adam	19660512	1362	Site B	12345	Site B	1.2.2
Smith	Adam	19660512	1528	Site C	47289	Site C	1.2.12
Jones	Paul	19720125	2048	Site A	35732	Site A	1.2.3
Brown	David	19700101	6319	Site A	93717	Site A	1.2.13
Brown	David	19661201	6319	Site B	03962	Site B	1.2.14

1545 **The Issuer values in the table above only show the Namespace ID value. The table below lists the additional values for these Assigning Authorities:**

Issuer Namespace ID	Universal ID	Universal ID Type
Site A	1.2.mm.nnnnn.111.1111	ISO
Site B	1.2.xx.yyyyy.222.2222	ISO
Site C	1.2.xx.zzzz.33.33333	ISO

**The following tables describes DICOM query-retrieve requests and the corresponding responses.**

**General table structure:**

- 1550 • **The Query table lists the DICOM attributes and values sent as the query request identifier in the Data Set of a C-FIND Request. The Query Root and Query Level of the query are also indicated:**
  - **Root (Patient, Study)**
  - **Level (Patient, Study, Series, Instance)**

- 1555
- **The Responses table lists the DICOM attributes and values sent as the query responses in the Data Sets of the corresponding C-FIND Responses. Each query response of a separate C-FIND Response is identified by a number in the “# “column of the table.**

**J.1.3.1.1: Patient Level Query by Patient ID with Issuer of Patient ID**

1560 **The following example is for use case J.1.3 as illustrated in figure J.1-3. It shows how the centralized Image Manager/Archive receiving a query from a local Image Manager/Archive handles the case where it has a single patient with multiple patient identifiers from different assigning authorities.**

1565 **The local Image Manager/Archive from the domain using the “Site B” Assigning Authority for both patient identifiers and Accession Numbers is querying the centralized Image Manager/Archive.**

**The local Image Manager/Archive issues the following query request to the centralized Image Manager/Archive:**

Query				
Root	Level	Tag	Attribute	Value
Patient	Patient	(0010,0010)	Patient Name	
		(0010,0020)	Patient ID	1362
		(0010,0021)	Issuer of Patient ID	Site B
		(0010,1002)	Other Patient IDs Sequence	

1570 **The query request identifier specifies a Patient ID (0010,0020) value to be matched as well as the Issuer of Patient ID (0010,0021) for that value. The centralized Image Manager/Archive database contains a match for that patient so returns the matching information. The query request identifier contains the Other Patient IDs Sequence (0010,1002) so the centralized Image Manager/Archive returns all known Patient IDs for that patient.**

1575 **The application of DICOM matching rules to the following query request identifier results in the following response:**

Responses			
#	Tag	Attribute	Value
1	(0010,0010)	Patient Name	Smith^Adam
	(0010,0020)	Patient ID	1362
	(0010,0021)	Issuer of Patient ID	Site B
	(0010,1002)	Other Patient IDs Sequence	
	>(0010,0020)	Patient ID	1824
	>(0010,0021)	Issuer of Patient ID	Site A

Responses			
#	Tag	Attribute	Value
	>(0010,0020)	Patient ID	1362
	>(0010,0021)	Issuer of Patient ID	Site B
	>(0010,0020)	Patient ID	1528
	>(0010,0021)	Issuer of Patient ID	Site C

**J.1.3.1.2: Patient Level Query by Patient Demographics**

1580 **The following example is for use case J.1.3 as illustrated in figure J.1-3. The local Image Manager/Archive is again querying the centralized Image Manager/Archive but this time doing a patient demographics search rather than querying by patient identifier.**

**The local Image Manager/Archive from the domain using the “Site B” Assigning Authority for both patient identifiers and Accession Numbers is querying the centralized Image Manager/Archive.**

1585 **The local Image Manager/Archive issues the following query request to the centralized Image Manager/Archive:**

Query				
Root	Level	Tag	Attribute	Value
Patient	Patient	(0010,0010)	Patient Name	Smith^Adam
		(0010,0020)	Patient ID	
		(0010,0021)	Issuer of Patient ID	Site B
		(0010,1002)	Other Patient IDs Sequence	

1590 **The query request identifier specifies a Patient Name value to be matched, and also includes the Patient ID (0010,0010) and Issuer of Patient ID (0010,0021) attributes. The centralized Image Manager/Archive database contains a match for that patient so returns the matching information. The query request specifies that the returned Patient ID should be from the “Site B” Assigning Authority by including the Issuer of Patient ID (0010,0021) with the value “Site B” in the query. The query request identifier contains the Other Patient IDs Sequence (0010,1002) so the centralized Image Manager/Archive returns all known Patient IDs for that patient.**

Responses			
#	Tag	Attribute	Value
1	(0010,0010)	Patient Name	Smith^Adam

Responses			
#	Tag	Attribute	Value
	(0010,0020)	Patient ID	1362
	(0010,0021)	Issuer of Patient ID	Site B
	(0010,1002)	Other Patient IDs Sequence	
	>(0010,0020)	Patient ID	1824
	>(0010,0021)	Issuer of Patient ID	Site A
	>(0010,0020)	Patient ID	1362
	>(0010,0021)	Issuer of Patient ID	Site B
	>(0010,0020)	Patient ID	1528
	>(0010,0021)	Issuer of Patient ID	Site C

1595 **J.1.3.1.3: Patient Level Query with no Matching Patient ID for the Specified Issuer of Patient ID**

**The following example is for use case J.1.3 as illustrated in figure J.1-3. It illustrates how the centralized Image Manager/Archive handles a Patient Level query for which it has a matching patient record, but no Patient ID value for the requested Issuer of Patient ID (0010,0021).**

1600 **The local Image Manager/Archive from the domain using the “Site B” Assigning Authority for both patient identifiers and Accession Numbers is querying the centralized Image Manager/Archive.**

**The local Image Manager/Archive issues the following query request to the centralized Image Manager/Archive:**

Query				
Root	Level	Tag	Attribute	Value
Patient	Patient	(0010,0010)	Patient Name	Jones^Paul
		(0010,0020)	Patient ID	
		(0010,0021)	Issuer of Patient ID	Site B
		(0010,1002)	Other Patient IDs Sequence	

1605 **The centralized Image Manager/Archive does not actually have a patient identifier for the patient “Jones^Paul” that was assigned by “Site B”. Thus, it shall respond that there are no matches because Patient ID is a Unique Key for Patient Root, Patient Level queries, and cannot be returned as a blank value.**

**J.1.3.1.4: Patient Level Query with no Specified Issuer of Patient ID Value**

1610 **The following example is for use case J.1.3 as illustrated in figure J.1-3. It illustrates how the centralized Image Manager/Archive handles a Patient Level query when there is no preconfigured Patient ID Assigning Authority associated with the querying Image Manager/Archive and the query request also does not specify a Patient ID Assigning Authority.**

1615 **In the following example, the local Image Manager/Archive from “Site B” is querying the centralized Image Manager/Archive. It issues the following query request to the centralized Image Manager/Archive:**

Query				
Root	Level	Tag	Attribute	Value
Patient	Patient	(0010,0010)	Patient Name	Jones^Paul
		(0010,0020)	Patient ID	
		(0010,0021)	Issuer of Patient ID	
		(0010,1002)	Other Patient IDs Sequence	

1620 **The centralized Image Manager/Archive does not have a preconfigured patient identifier Assigning Authority associated with the querying Image Manager/Archive. In addition, no Issuer of Patient ID (0010,0021) is specified in the query request identifier. This means that the centralized Image Manager/Archive is free to return a Patient ID value from any Assigning Authority. It shall return all known Patient IDs in the Other Patient IDs Sequence.**

Responses			
#	Tag	Attribute	Value
1	(0010,0010)	Patient Name	Jones^Paul
	(0010,0020)	Patient ID	2048
	(0010,0021)	Issuer of Patient ID	Site A
	(0010,1002)	Other Patient IDs Sequence	
	>(0010,0020)	Patient ID	2048
	>(0010,0021)	Issuer of Patient ID	Site A

1625 **J.1.3.1.5: Study Level Query with no Matching Patient ID for the Assigning Authority**

**The following example is for use case J.1.3 as illustrated in figure J.1-3. It illustrates how the centralized Image Manager/Archive handles a Study Root, Study Level query for which it has a matching patient record, but no Patient ID value for the requested Issuer of Patient ID (0010,0021).**

1630

**The local Image Manager/Archive from the domain using the “Site B” Assigning Authority for both patient identifiers and Accession Numbers is querying the centralized Image Manager/Archive. It issues the following query request to the centralized Image Manager/Archive:**

Query				
Root	Level	Tag	Attribute	Value
Study	Study	(0010,0010)	Patient Name	Brown^David
		(0010,0020)	Patient ID	
		(0010,0021)	Issuer of Patient ID	Site B
		(0010,1002)	Other Patient IDs Sequence	
		(0008,0050)	Accession Number	
		(0008,0051)	Issuer of Accession Number Sequence	
		(0020,000D)	Study UID	

1635

**In this example, the centralized Image Manager returns a blank Patient ID value for the first matching response because it does not have a Patient ID for this patient that was issued by “Site B”.**

Responses			
#	Tag	Attribute	Value
1	(0010,0010)	Patient Name	Brown^David
	(0010,0020)	Patient ID	
	(0010,0021)	Issuer of Patient ID	Site B
	(0010,1002)	Other Patient IDs Sequence	
	>(0010,0020)	Patient ID	6319
	>(0010,0021)	Issuer of Patient ID	Site A
	(0008,0050)	Accession Number	93717
	(0008,0051)	Issuer of Accession Number Sequence	
	>(0040,0031)	Local Namespace Entity ID	Site A
	>(0040,0032)	Universal Entity ID	1.2.mm.nnnnn.111.1111
	>(0040,0033)	Universal Entity ID Type	ISO

Responses			
#	Tag	Attribute	Value
	(0020,000D)	Study UID	1.2.13
2	(0010,0010)	Patient Name	Brown^David
	(0010,0020)	Patient ID	6319
	(0010,0021)	Issuer of Patient ID	Site B
	(0010,1002)	Other Patient IDs Sequence	
	>(0010,0020)	Patient ID	6319
	>(0010,0021)	Issuer of Patient ID	Site B
	(0008,0050)	Accession Number	03962
	(0008,0051)	Issuer of Accession Number Sequence	
	>(0040,0031)	Local Namespace Entity ID	Site B
	>(0040,0032)	Universal Entity ID	1.2.xx.yyyyy.222.2222
	>(0040,0033)	Universal Entity ID Type	ISO
	(0020,000D)	Study UID	1.2.14

**J.1.3.1.5: Study Level Query with Constrained on Patient ID and Issuer of Patient ID**

1640 **The following example is for use case J.1.3 as illustrated in figure J.1-3. It illustrates how the centralized Image Manager/Archive handles a Study Root, Study Level query that specifies both a Patient ID (0010,0020) value and its Issuer of Patient ID (0010,0021).**

1645 **The local Image Manager/Archive from the domain using the “Site B” Assigning Authority for both patient identifiers and Accession Numbers is querying the centralized Image Manager/Archive. It issues the following query request to the centralized Image Manager/Archive:**

Query				
Root	Level	Tag	Attribute	Value
Study	Study	(0010,0010)	Patient Name	
		(0010,0020)	Patient ID	1362
		(0010,0021)	Issuer of Patient ID	Site B
		(0010,1002)	Other Patient IDs Sequence	
		(0008,0050)	Accession Number	
		(0008,0051)	Issuer of Accession Number Sequence	
		(0020,000D)	Study UID	



**In this example, the centralized Image Manager returns three matching Studies for this query. It returns the “Site B” Patient ID for all three matches as this is the Assigning Authority specified in the query request.**

Responses			
#	Tag	Attribute	Value
1	(0010,0010)	Patient Name	Smith^Adam
	(0010,0020)	Patient ID	1362
	(0010,0021)	Issuer of Patient ID	Site B
	(0010,1002)	Other Patient IDs Sequence	
	>(0010,0020)	Patient ID	1824
	>(0010,0021)	Issuer of Patient ID	Site A
	>(0010,0020)	Patient ID	1362
	>(0010,0021)	Issuer of Patient ID	Site B
	>(0010,0020)	Patient ID	1528
	>(0010,0021)	Issuer of Patient ID	Site C
	(0008,0050)	Accession Number	12345
	(0008,0051)	Issuer of Accession Number Sequence	
	>(0040,0031)	Local Namespace Entity ID	Site A
	>(0040,0032)	Universal Entity ID	1.2.mm.nnnnn.111.1111
	>(0040,0033)	Universal Entity ID Type	ISO
	(0020,000D)	Study UID	1.2.1
	2	(0010,0010)	Patient Name
(0010,0020)		Patient ID	1362
(0010,0021)		Issuer of Patient ID	Site B
(0010,1002)		Other Patient IDs Sequence	
>(0010,0020)		Patient ID	1824
>(0010,0021)		Issuer of Patient ID	Site A
>(0010,0020)		Patient ID	1362
>(0010,0021)		Issuer of Patient ID	Site B
>(0010,0020)		Patient ID	1528
>(0010,0021)		Issuer of Patient ID	Site C
(0008,0050)		Accession Number	12345
(0008,0051)		Issuer of Accession Number Sequence	

Responses			
#	Tag	Attribute	Value
	>(0040,0031)	Local Namespace Entity ID	Site B
	>(0040,0032)	Universal Entity ID	1.2.xx.yyyyy.222.2222
	>(0040,0033)	Universal Entity ID Type	ISO
	(0020,000D)	Study UID	1.2.2
3	(0010,0010)	Patient Name	Smith^Adam
	(0010,0020)	Patient ID	1362
	(0010,0021)	Issuer of Patient ID	Site B
	(0010,1002)	Other Patient IDs Sequence	
	>(0010,0020)	Patient ID	1824
	>(0010,0021)	Issuer of Patient ID	Site A
	>(0010,0020)	Patient ID	1362
	>(0010,0021)	Issuer of Patient ID	Site B
	>(0010,0020)	Patient ID	1528
	>(0010,0021)	Issuer of Patient ID	Site C
	(0008,0050)	Accession Number	47289
	(0008,0051)	Issuer of Accession Number Sequence	
	>(0040,0031)	Local Namespace Entity ID	Site C
>(0040,0032)	Universal Entity ID	1.2.xx.zzzz.33.33333	
>(0040,0033)	Universal Entity ID Type	ISO	
(0020,000D)	Study UID	1.2.12	

## **J.2: Multiple Identity Resolution Transaction Specifications**

1650 **This section defines common specifications that shall be supported by an Image Manager/Archive supporting the Multiple Identify Resolution option for the Scheduled Workflow and Patient Information Reconciliation Profiles. It includes requirements for**

- **Cross-Referencing of Patient Identifiers (Section J.2.1)**
- **Configurable Mapping to Default Assigning Authorities and Institution Name (Section J.2.2)**
- **Expected Actions when Receiving Scheduled or Updated Procedures (Section J.2.3)**
- **Handling of Assigning Authorities when Exchanging SOP Instances (Section J.2.4)**
- **Handling of Assigning Authorities in Performed Procedure Steps (Section J.2.5)**

- Handling of Assigning Authorities in Queries (Section J.2.6)
- 1660 • Handling of Assigning Authorities for Retrieval Requests (Section J.2.7)

### J.2.1: Cross-Referencing of Patient Identifiers

The Image Manager/Archive shall support the ability to cross-reference multiple patient identifiers, with different Patient ID Assigning Authority values, belonging to the same patient.

- 1665 • The Image Manager/Archive shall be capable of handling the Assigning Authority information associated with a Patient ID (conveyed in the HL7 Patient ID namespace ID or the DICOM Issuer of Patient ID (0010,0021)) so that it can support multiple patient identifier domains.
- 1670 • The Image Manager/Archive shall be grouped with a Patient Identifier Cross-Reference (PIX) Consumer in order to obtain the cross-referencing of patient identifiers. As a PIX Consumer it shall support the PIX Query [ITI-9] (see ITI TF-2a: 3.9) transaction. It can also choose to support the optional PIX Update Notification [ITI-10] (see ITI TF-2a: 3.10) transaction.
- 1675 • The Image Manager/Archive shall be grouped with a Patient Identifier Cross-reference (PIX) Consumer so that it can use the PIX Query transaction to obtain a patient identifier from a patient identifier domain it supports if it receives a patient identifier from an unsupported domain.
- 1680 • If supporting the optional PIX Update Notification transaction, the Image Manager/Archive shall support receiving notifications related to all the patient identifier domains that the Image Manager/Archive claims to support.
- The Multiple Identity Resolution option does not mandate precise trigger points that the Image Manager/Archive must support for issuing PIX Query transactions to get the most up to date patient identifier cross-referencing. It is left to the implementer to define this internal behavior of the system.
- 1685 • The Image Manager/Archive is only required to use the cross-referencing of patient identifiers provided by the PIX Manager in order to determine whether or not two different patient identifiers belong to the same patient. It is not required to support internal heuristic based patient matching.

1690 Support for this option does not require support for Import Reconciliation Workflow or XDS-I.b Imaging Document Consumer or Imaging Document Source functionality by the Image Manager/Archive.

1695 If an Image Manager/Archive supporting the Multiple Identity Resolution option is also acting as an XDS-I.b Imaging Document Consumer or Imaging Document Source then one of the patient identifiers being cross-referenced shall belong to the Patient Identification Domain (Assigning Authority) used by the XDS Document Registry.

**J.2.2: Configurable Mapping to Default Assigning Authorities and Institution Name**

1700 **The Image Manager/Archive that supports the Multiple Identity Resolution option shall maintain a configurable mapping of default Patient ID Assigning Authority, Accession Number Assigning Authority, and Institution Name information for systems it communicates with as defined in the following sub-sections.**

**J.2.2.1: Patient ID Assigning Authority and Accession Number Assigning Authority Mapping**

1705 **The Image Manager/Archive that supports the Multiple Identity Resolution option shall convey the following Assigning Authority values. The following table lists the corresponding DICOM and HL7 attributes for these Assigning Authority values:**

**Table J.2.2.1-1. Assigning Authority Attributes**

<u>Assigning Authority</u>	<u>DICOM Description</u>	<u>DICOM Tag</u>	<u>HL7 Element Name</u>	<u>HL7 Item #</u>	<u>HL7 Segment</u>	<u>HL7 Component</u>
<u>Patient Identifier Assigning Authority</u>	<u>Issuer of Patient ID</u>	<u>(0010,0021)</u>	<u>Patient Identifier List</u>	<u>00106.4</u>	<u>PID:3</u>	<u>Component 4: &lt;assigning authority&gt; Sub-component 1: &lt;namespace ID&gt;</u>
<u>Accession Number Assigning Authority</u>	<u>Issuer of Accession Number Sequence</u>	<u>(0008,0051)</u>	<u>Filler Order #</u>	<u>00217</u>	<u>ORC-3 Or OBR-3</u>	
	<u>&gt;Local Namespace Entity ID</u>	<u>(0040,0031)</u>		<u>00217.2</u>		<u>Component 2: &lt;namespace ID&gt;</u>
	<u>&gt;Universal Entity ID</u>	<u>(0040,0032)</u>		<u>00217.3</u>		<u>Component 3: &lt;universal ID&gt;</u>
	<u>&gt;Universal Entity ID Type</u>	<u>(0040,0033)</u>		<u>00217.4</u>		<u>Component 4: &lt;universal ID type&gt;</u>

1710 **The Image Manager/Archive that supports the Multiple Identity Resolution option shall maintain a configurable mapping of a default Patient ID Assigning Authority, Issuer of Patient ID (0010,0021), and a default Accession Number Assigning Authority, Issuer of Accession Number Sequence (0008,0051):**

- **To each DSS/Order Filler from which it receives Procedure Scheduled [RAD-4], or Procedure Updated [RAD-13] transactions and take this mapping into account to establish the Assigning Authority of included Accession Numbers. See J.2.3.**
- **to each Acquisition Modality and Evidence Creator for which it stores DICOM objects and take this mapping into account storing objects sent from these systems. See J.2.4.1.**

- 1720
- to each Image Display for which it responds to DICOM query/retrieve requests and take this mapping into account in its query/retrieve responses to these systems. See J.2.6 and J.2.7.

An Image Manager/Archive shall support the configurable mapping to a particular default Accession Number Assigning Authority for each DSS/Order Filler:

- 1725
- Based on the host name or IP address of the DSS/Order Filler.
  - By the combination of sending application in MSH-3 and sending facility in MSH-4
  - Note that it is mandatory for the DSS/Order Filler to specify the Patient ID Assigning Authority, in the first subcomponent (namespace ID) of Component 4 of the PID-3 field, so no such configurable mapping is needed for this.

1730

An Image Manager/Archive shall support the configurable mapping to a particular default Patient ID Assigning Authority for each Acquisition Modality, Evidence Creator, Image Display, and Image Manager/Archive based on the following values for these systems:

- Host name or IP address
- AE Title

1735

It shall support the configurable mapping to a particular default Accession Number Assigning Authority for each Acquisition Modality, Evidence Creator and Image Display based on the following values for these systems:

- Host name or IP address
- AE Title

1740

If there is no configured default Accession Number Assigning Authority associated with a system to which an Image Manager/Archive is sending SOP Instances, then the Image Manager/Archive shall assume that the system can handle Accession Numbers from other domains.

1745

For handling C-MOVE Retrieval Requests, the Image Manager/Archive shall support this configurable mapping for both the requestor system sending the C-MOVE Request and for the C-MOVE Destination Application Entity to which the requested SOP Instances are to be sent.

### J.2.2.2 Institution Name Mapping

1750

The Image Manager/Archive needs to be able to determine the actual site where data was originally acquired. The Accession Number Assigning Authority does not necessarily indicate this information as the Accession Number could be different from what it was when the data was acquired due to Import Reconciliation Workflow or other undefined workflow use cases.

**To determine where the data was acquired, the Image Manager/Archive that supports the Multiple Identity Resolution option shall maintain a configurable mapping of a default Institution Name (0008,0080) and Institution Code Sequence (0008,0082):**

- 1755
- **to each Acquisition Modality and Evidence Creator for which it stores DICOM objects and take this mapping into account storing objects sent from these systems. See J.2.4.1.**

**It shall support the configurable mapping to a particular default Institution Name and Institution Code Sequence based on each of the following values for these systems:**

- 1760
- **Host name or IP address**
  - **Source AE Title**

### **J.2.3: Expected Actions when Receiving Scheduled or Updated Procedures**

1765 **The Image Manager/Archive receiving Procedure Scheduled [RAD-4] or Procedure Updated [RAD-13] transactions shall establish the Assigning Authority of the Patient ID from the information sent in PID-3. The Assigning Authority of the Accession Number shall be determined by the information sent in ORC-3 or OBR-3, or if absent, from the preconfigured Assigning Authority of the Accession Number associated with the DSS/OF sending these transactions.**

### **J.2.4: Handling of Assigning Authorities when Exchanging SOP instances**

1770 **The following sub-sections specify the requirements an Image Manager/Archive shall support when sending and receiving SOP Instances.**

#### **J.2.4.1: Message Semantics when Sending SOP Instances**

1775 **The Image Manager/Archive sending a SOP Instance shall provide DICOM attributes conveying the Assigning Authorities of the Patient ID and Accession Number. It shall also convey the Institution Name (0008,0080) and Institution Code Sequence (0008,0082) so that the institution where the SOP Instance was created is identified.**

1780 **If there is no patient identifier value defined for the preconfigured default Assigning Authority of the receiving Application Entity then the Patient ID value shall be left blank. If there is no preconfigured default Assigning Authority for the receiving Application Entity then the Image Manager can specify a Patient ID value from any Assigning Authority in the images.**

**The Image Manager shall support sending attributes in the images as defined in the following table:**

**Table J.2.4.1-1. SOP Instance Attributes for Multiple Identity Resolution**

<b><u>Attribute</u></b>	<b><u>Tag</u></b>	<b><u>Required</u></b>	<b><u>Rationale</u></b>
-------------------------	-------------------	------------------------	-------------------------

<u>Attribute</u>	<u>Tag</u>	<u>Required</u>	<u>Rationale</u>
<u>Patient's Name</u>	<u>(0010,0010)</u>	<u>RC+</u>	<u>This Name is referred to in this Appendix as the destination Patient's Name.</u> <u>Required if a Patient Name is known for the patient.</u>
<u>Patient ID</u>	<u>(0010,0020)</u>	<u>RC+</u>	<u>Used to identify the patient.</u> <u>Required if a Patient ID value is known for the Assigning Authority of the destination system. May be present otherwise.</u> <u>This ID is referred to in this Appendix as the destination Patient ID.</u>
<u>Issuer of Patient ID</u>	<u>(0010,0021)</u>	<u>RC+</u>	<u>Used to identify the Assigning Authority (system, organization, agency, or department) that issued the Patient ID.</u> <u>Required if Patient ID is not empty.</u>
<u>Issuer of Patient ID Qualifiers Sequence</u>	<u>(0010,0024)</u>	<u>O</u>	
<u>≥Universal Entity ID</u>	<u>(0040,0032)</u>	<u>O</u>	
<u>≥Universal Entity ID Type</u>	<u>(0040,0033)</u>	<u>O</u>	
<u>≥Identifier Type Code</u>	<u>(0040,0035)</u>	<u>O</u>	
<u>≥Assigning Facility Sequence</u>	<u>(0040,0036)</u>	<u>O</u>	
<u>≥Assigning Jurisdiction Code Sequence</u>	<u>(0040,0039)</u>	<u>O</u>	
<u>≥Assigning Agency or Department Code Sequence</u>	<u>(0040,003A)</u>	<u>O</u>	
<u>Other Patient IDs</u>	<u>(0010,1000)</u>	<u>Not Permitted</u>	<u>Redundant with (0010,1002) and insufficient as it does not allow the Assigning Authority to be conveyed for each Patient ID.</u>
<u>Other Patient IDs Sequence</u>	<u>(0010,1002)</u>	<u>RC+</u>	<u>Used to convey known patient identifiers for the patient.</u> <u>Required if a Patient ID is known for the patient.</u>
<u>≥Patient ID</u>	<u>(0010,0020)</u>	<u>R+</u>	
<u>≥Issuer of Patient ID</u>	<u>(0010,0021)</u>	<u>R+</u>	

<u>Attribute</u>	<u>Tag</u>	<u>Required</u>	<u>Rationale</u>
<u>&gt;Issuer of Patient ID Qualifiers Sequence</u>	<u>(0010,0024)</u>	<u>O</u>	
<u>&gt;&gt;Universal Entity ID</u>	<u>(0040,0032)</u>	<u>O</u>	
<u>&gt;&gt;Universal Entity ID Type</u>	<u>(0040,0033)</u>	<u>O</u>	
<u>&gt;&gt;Identifier Type Code</u>	<u>(0040,0035)</u>	<u>O</u>	
<u>&gt;&gt;Assigning Facility Sequence</u>	<u>(0040,0036)</u>	<u>O</u>	
<u>&gt;&gt;Assigning Jurisdiction Code Sequence</u>	<u>(0040,0039)</u>	<u>O</u>	
<u>&gt;&gt;Assigning Agency or Department Code Sequence</u>	<u>(0040,003A)</u>	<u>O</u>	
<u>&gt;Type of Patient ID</u>	<u>(0010,0022)</u>	<u>R</u>	
<u>Other Patient Names</u>	<u>(0010,1001)</u>	<u>RC+</u>	<u>Used to convey known patient names for the patient. Required if a Patient Name is known for the patient.</u>
<u>Accession Number</u>	<u>(0008,0050)</u>	<u>O</u>	<u>Used to identify the order for the Study.</u>
<u>Issuer of Accession Number Sequence</u>	<u>(0008,0051)</u>	<u>RC+</u>	<u>Used to identify the Assigning Authority that issued the Accession Number. Required if Accession Number is not empty.</u>
<u>&gt;Local Namespace Entity ID</u>	<u>(0040,0031)</u>	<u>R+</u>	
<u>&gt;Universal Entity ID</u>	<u>(0040,0032)</u>	<u>R+</u>	
<u>&gt;Universal Entity ID Type</u>	<u>(0040,0033)</u>	<u>R+</u>	
<u>Institution Name</u>	<u>(0008,0080)</u>	<u>R+</u>	<u>Used to convey the institution where the SOP Instance was created.</u>
<u>Institution Code Sequence</u>	<u>(0008,0082)</u>	<u>R+</u>	<u>Used to convey the institution where the SOP Instance was created.</u>
<u>&gt;Code Value</u>	<u>(0008,0100)</u>	<u>R</u>	



<u>Attribute</u>	<u>Tag</u>	<u>Required</u>	<u>Rationale</u>
<u>&gt;Coding Scheme Designator</u>	<u>(0008,0102)</u>	<u>R</u>	
<u>&gt;Coding Scheme Version</u>	<u>(0008,0103)</u>	<u>RC</u>	<u>Required if the value of Coding Scheme Designator (0008,0102) is not sufficient to identify the Code Value (0008,0100) unambiguously. May be present otherwise.</u>
<u>&gt;Code Meaning</u>	<u>(0008,0104)</u>	<u>R</u>	

#### 1785 **J.2.4.1.1: Usage of Other Patient IDs and Names**

**The Image Manager shall be capable of including all patient identifiers known to it in the Other Patient IDs Sequence (0010,1002).**

1790 **The Image Manager shall support the ability to configure to not send all known patient identifiers. This allows domains to place restrictions on the amount of patient information that can be conveyed between systems due to privacy policies.**

**At a minimum the Image Manager shall include in the Other Patient IDs Sequence (0010,1002) the destination Patient ID value, if it exists.**

**The Image Manager shall be capable of including all patient names known to it in the Other Patient Names (0010,1001).**

1795 **At a minimum the Image Manager shall include in the Other Patient Names (0010,1001) the destination Patient Name value, if it exists.**

#### **J.2.4.2: Expected Actions when Receiving SOP Instances**

1800 **The Image Manager/Archive receiving a SOP Instance shall establish the Assigning Authority of the Patient ID from the Issuer of Patient ID (0010,0021) attribute in the received SOP instance or, if absent, from the preconfigured Assigning Authority of the Patient ID associated with the source system.**

1805 **The Image Manager/Archive receiving a SOP Instance shall establish the Assigning Authority of the Accession Number from the Issuer of Accession Number Sequence (0008,0051) attribute in the received SOP instance or, if absent, from the preconfigured Assigning Authority of the Accession Number associated with the source system.**

1810 **The Image Manager/Archive receiving a SOP Instance shall establish the institution where the SOP Instance was created from the Institution Code Sequence (0008,0082) attribute in the received SOP instance or, if absent, from the preconfigured Institution Code Sequence associated with the source system. The Institution Name shall be the Code Meaning of the Institution Code Sequence. If the Institution Name is coerced then the original value shall be placed in the Original Attributes Sequence (0400,0561).**

#### **J.2.5: Handling of Assigning Authorities in Performed Procedure Steps**

1815 **An Image Manager/Archive supporting the Multiple Identity Resolution option shall meet the requirements in the following sub-sections for forwarding and receiving DICOM Performed Procedure Steps:**

**J.2.5.1 Message Semantics when Forwarding Performed Procedure Steps**

1820 **The Performed Procedure Step Manager that supports the Multiple Identity Resolution option shall provide DICOM attributes conveying the Assigning Authorities of the Patient ID and Accession Number in the Performed Procedure Step messages. It shall also convey the Institution Name (0008,0080) and Institution Code Sequence (0008,0082) so that the institution where the referenced SOP Instance were created is identified. It shall use the originally received Patient ID and Accession Number values in the forwarded message.**

1825 **The Performed Procedure Step Manager shall support sending the additional attributes in the Modality Performed Procedure Steps as defined in the following table. The Performed Procedure Step Manager shall add these attributes if they are not already present in the message.**

**Table J.2.5.1-1. Modality Performed Procedure Step Additional Attributes for Multiple Identity Resolution**

<u>Attribute</u>	<u>Tag</u>	<u>Required</u>	<u>Rationale</u>
------------------	------------	-----------------	------------------

<u>Attribute</u>	<u>Tag</u>	<u>Required</u>	<u>Rationale</u>
<b><u>Performed Procedure Step Relationship</u></b>			
<b><u>Scheduled Step Attribute Sequence</u></b>	<b><u>(0040,0270)</u></b>	<b><u>R</u></b>	
<b><u>&gt;Issuer of Accession Number Sequence</u></b>	<b><u>(0008,0051)</u></b>	<b><u>RC+</u></b>	<b><u>Used to identify the Assigning Authority that issued the Accession Number.</u></b> <b><u>Required if Accession Number is not empty.</u></b>
<b><u>&gt;&gt;Local Namespace Entity ID</u></b>	<b><u>(0040,0031)</u></b>	<b><u>R+</u></b>	
<b><u>&gt;&gt;Universal Entity ID</u></b>	<b><u>(0040,0032)</u></b>	<b><u>R+</u></b>	
<b><u>&gt;&gt;Universal Entity ID Type</u></b>	<b><u>(0040,0033)</u></b>	<b><u>R+</u></b>	
<b><u>Patient's Name</u></b>	<b><u>(0010,0010)</u></b>	<b><u>RC+</u></b>	<b><u>This Name is referred to in this Appendix as the destination Patient's Name.</u></b> <b><u>Required if a Patient Name is known for the patient.</u></b>
<b><u>Patient ID</u></b>	<b><u>(0010,0020)</u></b>	<b><u>RC+</u></b>	<b><u>Used to identify the patient.</u></b> <b><u>Required if a Patient ID value is known for the Assigning Authority of the destination system. May be present otherwise.</u></b> <b><u>This ID is referred to in this Appendix as the destination Patient ID.</u></b>
<b><u>Issuer of Patient ID</u></b>	<b><u>(0010,0021)</u></b>	<b><u>RC+</u></b>	<b><u>Used to identify the Assigning Authority (system, organization, agency, or department) that issued the Patient ID.</u></b> <b><u>Required if Patient ID is not empty.</u></b>
<b><u>Issuer of Patient ID Qualifiers Sequence</u></b>	<b><u>(0010,0024)</u></b>	<b><u>Q</u></b>	
<b><u>&gt;Universal Entity ID</u></b>	<b><u>(0040,0032)</u></b>	<b><u>Q</u></b>	
<b><u>&gt;Universal Entity ID Type</u></b>	<b><u>(0040,0033)</u></b>	<b><u>Q</u></b>	
<b><u>&gt;Identifier Type Code</u></b>	<b><u>(0040,0035)</u></b>	<b><u>Q</u></b>	

### **J.2.5.2 Expected Actions when Receiving Performed Procedure Steps**

1830

**The Image Manager/Archive shall be capable of handling Modality Performed Procedure Step Messages from any of the patient identifier domains it is claiming to support. In**

1835 **addition to a local Image Manager/Archive directly connected to an Acquisition Modality or Evidence Creator, it is necessary for a centralized archive Image Manager/Archive to handle Modality Performed Procedure Steps in order to manage the Scheduled Workflow Group Case (RAD TF-2:4.6) and the Presentation of Grouped Procedures Profile (RAD TF-1:6).**

**J.2.6: Handling of Assigning Authorities in Queries**

**An Image Manager/Archive supporting the Multiple Identity Resolution option shall meet the requirements in the following sub-sections for sending and receiving DICOM queries:**

1840 **J.2.6.1 Message Semantics for Queries**

1845 **An Image Manager/Archive supporting the Multiple Identity Resolution option shall support the required matching and return keys defined in the following tables. Note that the Image Manager actor is not defined as both an SCU and SCP for the Query Images [RAD-14] transaction that specifies Table 4.14-1. The requirements for a querying Image Manager shall correspond to those of an SCU, and those for a receiving Image Manager shall correspond to those of an SCP in the following tables. However, the SCU display requirements defined in Table 4.14-1 do not apply to a querying Image Manager.**

- **RAD TF-1: Table 4.14-1. Images Query Matching and Return Keys**
- **Table J.2.6.1-1. Image Manager Multiple Identity Resolution Option Query Matching and Return Keys**

1855 **The tables specify if matching keys (keys used as matching criteria in the Query request) and returned keys (keys used to request attributes to be returned in the query responses) are Required (R) or Optional (O) for both the Query SCU and the Query SCP. Requirements indicated with R+ highlight the requirements added by the IHE Radiology Technical Framework. See RAD TF-2: 2.2 for more information on the usage conventions.**

**Matching on the Other Patient IDs Sequence for queries is not required by either the SCU or SCP. This would be redundant given that an Image Manager/Archive shall support the PIX Query [ITI-9] (and optionally the PIX Update Notification [ITI-10]) transaction.**

1860 **Table J.2.6.1-1. Image Manager Multiple Identity Resolution Option Query Matching and Return Keys**

<u>Attributes Name</u>	<u>Tag</u>	<u>Query Keys Matching</u>		<u>Query Keys Return</u>		<u>Notes</u>
		<u>SCU</u>	<u>SCP</u>	<u>SCU</u>	<u>SCP</u>	
<u>Study Level</u>						
<u>Issuer of Accession Number Sequence</u>	<u>(0008,0051)</u>					<u>IHE-2</u>
<u>&gt;Local Namespace Entity ID</u>	<u>(0040,0031)</u>	<u>R+*</u>	<u>R+</u>	<u>R+*</u>	<u>R+</u>	
<u>&gt;Universal Entity</u>	<u>(0040,0032)</u>	<u>R+*</u>	<u>R+</u>	<u>R+*</u>	<u>R+</u>	

<u>Attributes Name</u>	<u>Tag</u>	<u>Query Keys Matching</u>		<u>Query Keys Return</u>		<u>Notes</u>
		<u>SCU</u>	<u>SCP</u>	<u>SCU</u>	<u>SCP</u>	
<u>ID</u>						
<u>&gt;Universal Entity ID Type</u>	<u>(0040,0033)</u>	<u>R+*</u>	<u>R+</u>	<u>R+*</u>	<u>R+</u>	
<u>Issuer of Patient ID</u>	<u>(0010,0021)</u>	<u>R+*</u>	<u>R+</u>	<u>R+*</u>	<u>R+</u>	<u>IHE-1</u>
<u>Issuer of Patient ID Qualifiers Sequence</u>	<u>(0010,0024)</u>					
<u>&gt;Universal Entity ID</u>	<u>(0040,0032)</u>	<u>Q</u>	<u>Q</u>	<u>Q</u>	<u>Q</u>	
<u>&gt;Universal Entity ID Type</u>	<u>(0040,0033)</u>	<u>Q</u>	<u>Q</u>	<u>Q</u>	<u>Q</u>	
<u>&gt;Identifier Type Code</u>	<u>(0040,0035)</u>	<u>Q</u>	<u>Q</u>	<u>Q</u>	<u>Q</u>	
<u>Other Patient IDs Sequence</u>	<u>(0010,1002)</u>					
<u>&gt;Patient ID</u>	<u>(0010,0020)</u>	<u>Q</u>	<u>Q</u>	<u>Q</u>	<u>R+</u>	
<u>&gt;Issuer of Patient ID</u>	<u>(0010,0021)</u>	<u>Q</u>	<u>Q</u>	<u>Q</u>	<u>R+</u>	
<u>&gt;Issuer of Patient ID Qualifiers Sequence</u>	<u>(0010,0024)</u>					
<u>&gt;&gt;Universal Entity ID</u>	<u>(0040,0032)</u>	<u>Q</u>	<u>Q</u>	<u>Q</u>	<u>Q</u>	
<u>&gt;&gt;Universal Entity ID Type</u>	<u>(0040,0033)</u>	<u>Q</u>	<u>Q</u>	<u>Q</u>	<u>Q</u>	
<u>&gt;&gt;Identifier Type Code</u>	<u>(0040,0035)</u>	<u>Q</u>	<u>Q</u>	<u>Q</u>	<u>Q</u>	
<u>Series Level</u>						
<u>Institution Name</u>	<u>(0008,0080)</u>	<u>Q</u>	<u>Q</u>	<u>R+*</u>	<u>R+</u>	
<u>Institution Code Sequence</u>	<u>(0008,0082)</u>					
<u>&gt;Code Value</u>	<u>(0008,0100)</u>	<u>R+*</u>	<u>R+</u>	<u>R+*</u>	<u>R+</u>	
<u>&gt;Coding Scheme Designator</u>	<u>(0008,0102)</u>	<u>R+*</u>	<u>R+</u>	<u>R+*</u>	<u>R+</u>	
<u>&gt;Coding Scheme Version</u>	<u>(0008,0103)</u>	<u>R+*</u>	<u>R+</u>	<u>R+*</u>	<u>R+</u>	
<u>&gt;Code Meaning</u>	<u>(0008,0104)</u>	<u>R+*</u>	<u>R+</u>	<u>R+*</u>	<u>R+</u>	

**IHE-1: SCU shall be able to include a value for the Issuer of Patient ID (0010,0021) as a Matching Key in order to unambiguously identify the assigning authority for an included Patient ID value, or indicate which Patient ID assigning authority shall be used in responses if no Patient ID value is included. Assigning Authority conveyed in the Issuer of Patient ID only pertains to the context of the Patient ID value and not to any Studies or Series associated with a particular patient. Matching on this Assigning Authority does not mean that the SCP shall**

1870 **return only those Studies, Series, or SOP Instances that were acquired using that particular Issuer. If the SCU wants to query for only those Series, or SOP Instances acquired at a certain Institution then they shall use the Institution Code Sequence (0008,0082) as a Matching Key.**

1875 **IHE-2: SCUs shall be able to include values for the Issuer of Accession Number Sequence (0008,0051) as Matching Keys in order to unambiguously identify the assigning authority for an included Accession Number value, or indicate which Accession Number assigning authority shall be used in responses if no Accession Number value is included.**

### **J.2.6.2 Expected Actions when Handling Queries**

1880 **The receiving Image Manager shall support the matching and return keys defined in the following tables. The requirements for a receiving Image Manager shall correspond to those of an SCP in the following tables.**

- **RAD TF-1:Table 4.14-1. Images Query Matching and Return Keys**
- **Table J.2.6.1-1. Image Manager Multiple Identity Resolution Option Query Matching and Return Keys**

1885 **The receiving Image Manager shall support Patient ID and Accession Number Assigning Authorities, and DICOM Fuzzy Semantic Name Matching as defined in J.2.6.2.3.**

#### **J.2.6.2.1 Patient ID Assigning Authority in Queries**

- 1890 • **The Image Manager/Archive receiving query requests shall establish the Assigning Authority of an included Patient ID value from the Issuer of Patient ID (0010,0021) attribute that is explicitly present in the received query request identifier, or if absent, from the preconfigured Assigning Authority of the Patient ID associated with the querying system.**
- 1895 • **If there is no Patient ID value included in the query request then the Image Manager/Archive shall establish the Patient ID Assigning Authority to be used for all responses from the Issuer of Patient ID (0010,0021) attribute that is explicitly present in the received query request identifier, or if absent, from the preconfigured Assigning Authority of the Patient ID associated with the querying system.**
- 1900 • **The value of a returned Patient ID shall correspond to the Assigning Authority specified in the query, or if absent, the preconfigured Assigning Authority associated with the querying system. The Image Manager/Archive shall use its knowledge of the cross-referencing of patient identifiers to return the appropriate Patient ID value regardless of what patient identifier was used when any studies matching the query were acquired. If there is no such Patient ID then it shall be returned zero length.**

- 1905
- **In the case where the Issuer of Patient ID (0010,0021) attribute is sent with no value the Image Manager/Archive shall return responses with Patient ID values from any Assigning Authorities subject to the matching and return keys included in the query request identifier.**
- 1910
- **It shall return the particular Assigning Authority in the Issuer of Patient ID (0010,0021) returned in the matching response.**

#### **J.2.6.2.2 Accession Number Assigning Authority in Queries**

- 1915
- **The Image Manager/Archive receiving query requests shall establish the Assigning Authority of an included Accession Number value from the Issuer of Accession Number Sequence (0008,0051) attribute that is explicitly present in the received query request identifier, or if absent, from the preconfigured Assigning Authority of the Accession Number associated with the querying system.**
- 1920
- **If there is no Accession Number value included in the query request then the Image Manager/Archive shall establish the Accession Number Assigning Authority to be used for all responses from the Issuer of Accession Number Sequence (0008,0051) attribute that is explicitly present in the received query request identifier, or if absent, from the preconfigured Assigning Authority of the Accession Number associated with the querying system.**
- 1925
- **The value of a returned Accession Number shall correspond to the Assigning Authority specified in the query, or if absent, the preconfigured Assigning Authority associated with the querying system. If the Accession Number of a matching Study does not correspond to this Assigning Authority then it shall be returned zero length.**
- 1930
- **In the case where the Issuer of Accession Number Sequence (0008,0051) attribute is sent with no value the Image Manager/Archive can return Accession Number values from any Assigning Authority.**
  - **It shall return the particular Assigning Authority in the Issuer of Accession Number Sequence (0008,0051) returned in the matching response.**

#### **J.2.6.2.3 DICOM Fuzzy Semantic Matching**

- 1935
- **An Image Manager/Archive supporting the Multiple Identity Resolution option shall support the DICOM Fuzzy Semantic Matching of Person Names option. The Image Manager/Archive is not required to maintain separate patient demographics information for each patient domain as that would require it to support the functionality of a Patient Demographics Supplier. Instead, it shall support DICOM Fuzzy Semantic Matching so that variations in the spelling of a patient's name in different domains can still be handled. Refer to RAD TF-3: J.1.2.1.7 for examples of query-retrieve behavior.**
- 1940

### **J.2.7: Expected Actions for Retrieval Requests**

**An Image Manager/Archive supporting the Multiple Identity Resolution option shall meet the following requirements when handling received C-MOVE Requests:**

- 1945
- **If there is a preconfigured default Patient ID Assigning Authority for the C-MOVE Destination Application Entity then the Image Manager shall specify a Patient ID value from this Assigning Authority in the SOP Instances sent to the C-MOVE Destination Application Entity. If there is no Patient ID value defined for this preconfigured default Assigning Authority then the Patient ID value shall be left blank.**
- 1950
- **If there is no preconfigured default Patient ID Assigning Authority for the C-MOVE Destination Application Entity then the Image Manager can specify a Patient ID value from any Assigning Authority in the SOP Instances. It shall be assumed that the C-MOVE Destination Application Entity is capable of handling the corresponding Patient ID Assigning Authority information conveyed in the SOP Instances.**
- 1955
- **If there is a preconfigured default Accession Number Assigning Authority for the C-MOVE Destination Application Entity then the Image Manager shall only specify an Accession Number value from this Assigning Authority in the SOP Instances sent to the C-MOVE Destination Application Entity. If there is no Accession Number value defined for this preconfigured default Assigning Authority then the Accession Number value shall be left blank.**
- 1960
- **If there is no preconfigured default Accession Number Assigning Authority for the C-MOVE Destination Application Entity then the Image Manager can specify an Accession Number value from any Assigning Authority in the SOP Instances. It shall be assumed that the C-MOVE Destination Application Entity is capable of handling the corresponding Accession Number Assigning Authority information conveyed in the SOP Instances.**
- 1965
- **The Image Manager shall support Message Semantics when Sending SOP Instances (Section J.2.4.1)**
- 1970