

## Integrating the Healthcare Enterprise



5

# IHE Patient Care Device (PCD) Technical Framework Supplement

10

## Retrospective Data Query (RDQ)

15

## Trial Implementation

20

Date: August 16, 2012  
Author: IHE PCD Technical Committee  
Email: [pcd@ihe.net](mailto:pcd@ihe.net)

25

## Foreword

This is a supplement to the IHE Patient Care Device (PCD) Technical Framework V2.0. Each supplement undergoes a process of public comment and trial implementation before being incorporated into the volumes of the Technical Frameworks.

- 30 This supplement is published for Trial Implementation on August 16, 2012 and may be available for testing at subsequent IHE Connectathons. The supplement may be amended based on the results of testing. Following successful testing it will be incorporated into the PCD Technical Framework. Comments are invited and may be submitted at <http://www.ihe.net/pcd/pcdcomments.cfm>.
- 35 This supplement describes changes to the existing technical framework documents and where indicated amends text by addition (**bold underline**) or removal (~~**bold strikethrough**~~), as well as addition of new sections introduced by editor’s instructions to “add new text” or similar, which for readability are not bolded or underlined.
- 40 “Boxed” instructions like the sample below indicate to the Volume Editor how to integrate the relevant section(s) into the relevant Technical Framework volume:

<i>Replace Section X.X by the following:</i>
--

General information about IHE can be found at: [www.ihe.net](http://www.ihe.net)

- 45 Information about the IHE Patient Care Device domain can be found at:  
<http://www.ihe.net/Domains/index.cfm>

Information about the structure of IHE Technical Frameworks and Supplements can be found at:  
<http://www.ihe.net/About/process.cfm> and <http://www.ihe.net/profiles/index.cfm>

- 50 The current version of the IHE Technical Framework can be found at:  
[http://www.ihe.net/Technical\\_Framework/index.cfm](http://www.ihe.net/Technical_Framework/index.cfm)

## CONTENTS

	<b>INTRODUCTION TO THIS SUPPLEMENT</b> .....	<b>4</b>
55	OPEN ISSUES AND QUESTIONS.....	4
	CLOSED ISSUES.....	4
	<b>VOLUME 1 – PROFILES</b> .....	<b>6</b>
	COPYRIGHT PERMISSION.....	6
	DOMAIN-SPECIFIC ADDITIONS.....	6
60	<b>1 RETROSPECTIVE DATA QUERY PROFILE</b> .....	<b>7</b>
	1.1 RDQ ACTORS, TRANSACTIONS, AND CONTENT MODULES.....	8
	1.1.1 Actor Descriptions and Actor Profile Requirements.....	12
	1.2 RDQ ACTOR OPTIONS.....	12
	1.3 RDQ ACTOR REQUIRED GROUPINGS.....	12
65	1.4 RDQ OVERVIEW.....	12
	1.4.1 Concepts.....	12
	1.4.2 Use Case #1: Query for all retrospective data on a single patient.....	12
	1.4.3 Use Case #2: Query for all retrospective data on multiple patients.....	14
	1.4.4 Use Case #3: Query for retrospective data on a single patient within a specified time interval in the past.....	16
70	1.4.5 Use Case #4: Query for retrospective data on multiple patients within a specified time interval in the past.....	17
	1.4.6 Use Case #5: Query for retrospective data on 1 or more parameter elements on a single patient.....	18
	1.4.7 Use Case #6: Query for retrospective data on 1 or more parameter elements on multiple patients.....	20
75	1.4.8 Use Case #7: Query for retrospective data on 1 or more parameter elements on a single patient within a specified time interval in the past.....	22
	1.4.9 Use Case #8: Query for retrospective data on 1 or more parameter elements on multiple patients within a specified time interval in the past.....	23
	1.5 RDQ SECURITY CONSIDERATIONS.....	24
80	1.6 RDQ CROSS PROFILE CONSIDERATIONS.....	25
	<b>APPENDICES</b> .....	<b>26</b>
	<b>APPENDIX A: ACTOR SUMMARY DEFINITIONS</b> .....	<b>26</b>
	<b>APPENDIX B: TRANSACTION SUMMARY DEFINITIONS</b> .....	<b>26</b>
	<b>GLOSSARY</b> .....	<b>27</b>
85	<b>VOLUME 2 – TRANSACTIONS</b> .....	<b>28</b>
	3.1 RETROSPECTIVE DATA QUERY [PCD-12].....	28
	3.1.1 Scope.....	28
	3.1.2 Use Case Roles.....	28
	3.1.3 Referenced Standards.....	28
90	3.1.4 Interaction Diagram/ Messaging Sequence.....	29
	3.1.5 Security Considerations.....	37
	<b>VOLUME 3 – CONTENT MODULES</b> .....	<b>38</b>
	<b>VOLUME 4 – NATIONAL EXTENSIONS</b> .....	<b>39</b>

## 95 Introduction to this Supplement

Retrospective Data Query (RDQ) consists of patient specific, user-initiated queries of retrospective data stores of clinical data (i.e., retrospective data) for the purpose of aligning those data under a common time frame with the appropriate resolution to support clinical decision making based on said retrospective data. The RDQ is therefore patient centric and collects data from various sources (via multiple queries) to produce a comprehensive report that is meaningful to a given use case. Since the queries can occur in any order, some in real time and some from archived records, the “Retrospective” label was selected for this type of transaction integration profile.

Sources for retrospective clinical data retrieved from point of care medical devices can include (but are not limited to) electronic medical records (EMRs), patient care device gateways, individual medical devices and data marts. Clinical data can include any information that represent the latest, most accurate on a patient and can be timely (that is, within last second) or can be timely as in the latest valid measurement on a patient (e.g.: A1c that is 30 days old).

The scope of data types to be considered for RDQ can include waveforms, alarms and alerts, patient care device settings, and discrete clinical parameters both from patient care devices and systems within the healthcare environment (such as laboratory information systems, orders, medications, etc.,) corresponding to a more longitudinal view of the patient.

## Open Issues and Questions

1. The time base accuracy is currently the responsibility of the RDQ requestor relative to reported observations. Can this be done practically? *Suggested or initial response: Quality of Service (QoS) must decline gradually as there is a logical and gradual degradation in performance depending upon source for identifying or establishing precision.*
2. The working group evaluated whether there was a need for a discovery query, whereby the Retrospective Data Responder (RDR) would respond with initial metadata indicating what type of data were available. *Suggested or initial response: Individual medical devices in addition to Gateways could operate in the role of an RDR so long as they can respond to the RDC query. Furthermore, the type of Responder could be provided as an indicator back to the RDC.*

## 125 Closed Issues

1. Initial objections to developing this profile were based on the hypothesis as to whether the existing PCD02 transaction was sufficient to cover the desired functional aspects of RDQ. After considerable discussion it was decided that to use the existing PCD-02 Profile would “overload” that profile and would require considerable change to it. The WG recognized that some devices may require both DEC filtering for real-time data as well as RDQ for retrospective queries and that establishing 2 different profiles would be the best way of addressing this requirement. The WG also decided that from a testing standpoint it did not make sense to require a system that supported PCD-02 to support

- 135 both the filtering and query aspects. At the same time, while we would create new transactions for RDQ they would probably be based on the same HL7 message segments (such as OBR, OBX, QPD, etc.) but for the specific purpose of retrospective data query and response.
- 140 2. Accurate patient to data association will be required for each query and response. It is resolved that the RDQ system (Requestor and Server) will receive information from a Central Demographic Supplier.
- 145 3. Is “Consistent Time” (~1 second granularity) profile necessary in order to proceed with RDQ profile? *Response: We assume that the system responding to an RDQ query will have implemented the CT profile. We should note that some of the data from the responding system may have been aggregated from devices that do not support the CT profile. We assume UTC with whatever time offset, but not addressing basic discrepancies in the recording of time frame (i.e., different time frames used to record different data). As more granular and precise requirements evolve, will incorporate reference to profile.*
- 150 4. How to address overlap of the scope of this with other profiles that perform similar functions. *Response: Best treated as a new profile, separate from PCD02.*
- 155 5. Non-time-stamped requests or situations in which legacy patient care devices do not time stamp observations may receive a defacto time stamp from the clinician taking the observation. If this is the case, there may be no way to synchronize the absolute time of measurement with a reported time as recorded by a clinician. Does this matter? *Response: use the best information available at the time, this solution is at least as good as current practice.*
- 160 6. The group considered the need for a data class identifier, whereby the initial query would contain a data class field indicating the type of data to be retrieved would be discrete trend data (enumerated type ‘T’), waveform (enumerated type ‘W’) or alarm log query (enumerated type ‘A’). *Response: Provide Data Class field with aforementioned enumeration types.*

165

## Volume 1 – Profiles

### Copyright Permission

Not applicable.

170 **Domain-specific additions**

Not applicable.

## 1 Retrospective Data Query Profile

175 Retrospective Data Query (RDQ) consists of patient specific user activated queries from existing stored clinical data (i.e., retrospective data) for the purpose of aligning that data under a unique time frame with the appropriate resolution to support clinical decisions. It can also be used by EMRs and other clinical information systems to backfill their databases.

180 The RDQ is, therefore, patient centric and collects data from various sources to produce a comprehensive report that is meaningful to a given use case. RDQ is recognized as supporting non-real-time query for retrospective data. These queries can occur in any order from archived records. Thus, the “Retrospective” label was selected for this type of transaction integration profile. Per the diagram of Figure-1, RDQ (PCD-12) queries may be initiated by an RDQ Consumer which may be any entity within the network of health information technology actors within the healthcare enterprise. For instance, these may be an electronic medical record system, 185 a clinical decision support system, a local clinical information system, etc. The RDQ query may be initiated in response to a request by an end user (i.e., clinician) with respect to the request for retrieval of information on a patient.

# [RDQ] Retrospective Data Query

Supports retrospective query of PCD data from databases.  
Supports Use Cases such as Clinical Decision Support,  
back-filling of EMR databases, etc.

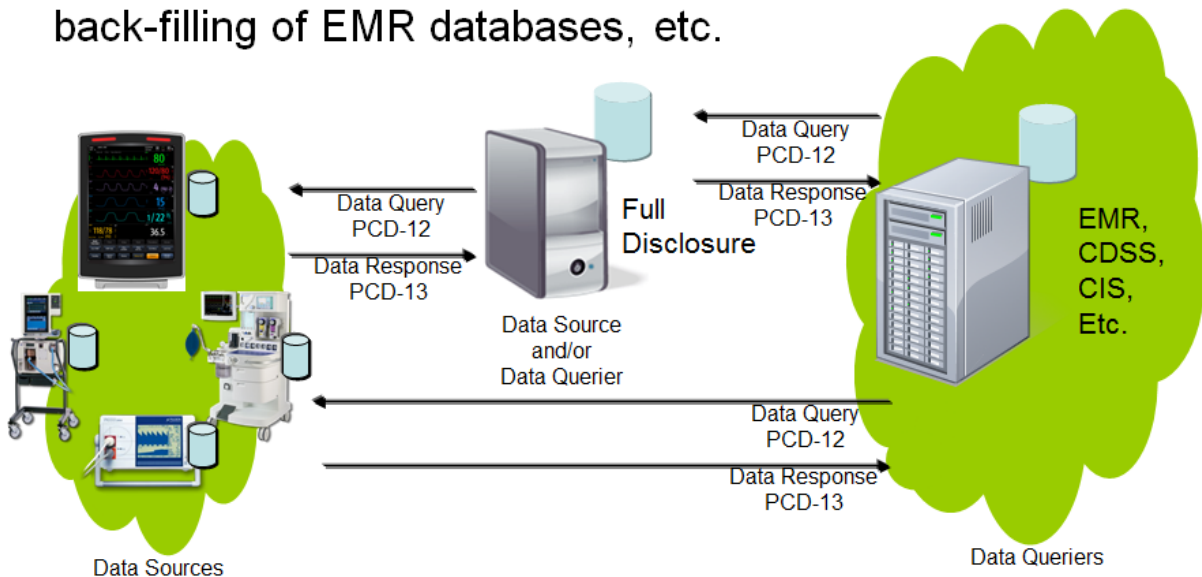

190 **Figure 1-1: Diagram illustrating anticipated communication protocols in the case of an RDQ data query. RDQ data queries are anticipated to be defined as PCD-12 transactions.**

## 1.1 RDQ Actors, Transactions, and Content Modules

195 A Retrospective Data Query (RDQ) in the form of a PCD-12 message is initiated by the RDQ Consumer through a message interface to repositories containing retrospective device data. The response to this RDQ message, the Retrospective Data Response, will represent the best efforts of the responder to fulfill the query. The working group evaluated whether there was a need for a discovery query, whereby the Retrospective Data Responder (RDR) would respond with initial metadata indicating what type of data were available (see Open Issues). Furthermore, the group is considering the need for a data class identifier, whereby the initial query would contain a data class field indicating the type of data to be retrieved would be discrete trend data (enumerated type 'T'), waveform (enumerated type 'W') or alarm log query (enumerated type 'A') (see Closed Issues). This remains a recommendation but as yet is unresolved how best to represent this message. Suggestions are presented in Volume 2 examples. Furthermore, the working group is evaluating as to whether specific channels need to be enumerated in the response.

200

205



210 Figure 1.1-1 shows the actors directly involved in the RDQ Profile and the relevant transactions between them. The RDQ Consumer contains a component defined as the Retrospective Data Consumer (RDC), shown in Figure 1.1-2, which initiates the RDQ request to a Retrospective Data Responder (RDR). The RDR would typically take on the form of a local repository for persistent device data. Hence, this would imply an entity such as a monitoring central station or equivalent, although individual devices could also operate as RDRs so long as they are capable of storing and responding to the queries initiated by the RDC. Therefore, the requests to the durable medical devices are out of scope for the RDQ.

215 The RDC may issue queries to federated repositories or RDRs, as is shown in Figure 1.1-2. Example systems that can participate as actors include:

RDC:

- Electronic Health Record / Electronic Medical Record Systems
- Clinical Decision Support Systems
- Research Data Warehouses

220 RDR:

- HL7 Gateways from physiologic or infusion vendors
- Medical device connectivity intermediary vendors that support data warehousing of medical device data

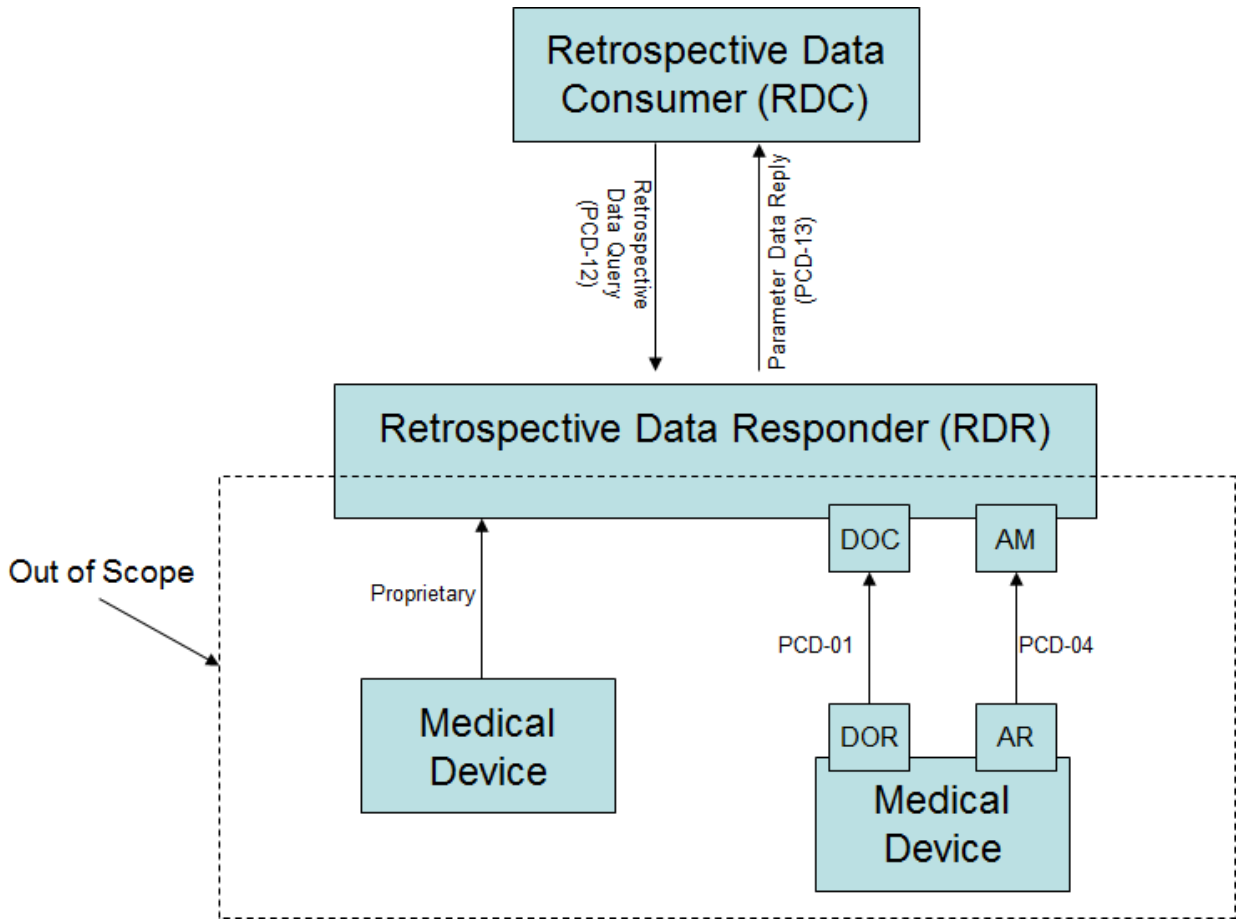
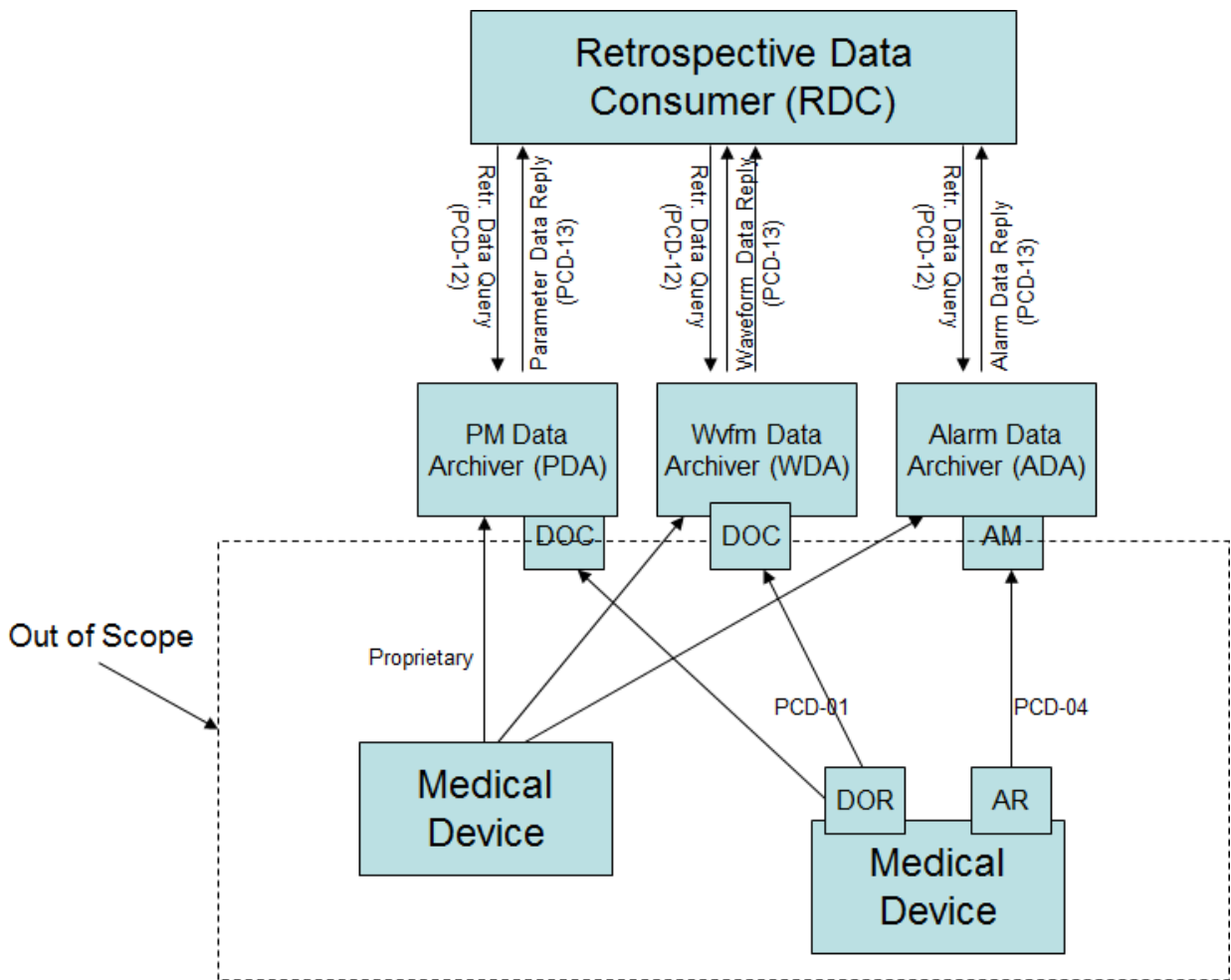

Figure 1.1-1: RDQ logical model illustrating RDQ Retrospective Data Consumer and Retrospective Data Responder.

225

230



**Figure 1.1-2: RDQ queries issued to separate, federated repositories. The same query maybe issued for trend, waveform, or alarm data.**

235 It is envisioned that a single query type can be used to elicit a response for more than one type of data, depending on the value of the enumerated data class field. Shown in this illustration are queries for point of care trend, waveform, and alarm data. This would require 3 queries from the RDC if the various archives were physically located on different systems.

240 Table 1.1-1 lists the transactions for each actor directly involved in the RDQ Profile. In order to claim support of this Profile, an implementation of an actor must perform the required transactions (labeled “R”) and may support the optional transactions (labeled “O”).

**Table 1.1-1: RDQ Profile - Actors and Transactions**

Actors	Transactions	Optionality	Section in Vol. 2
RDC	PCD-12	R	3.1.4
RDR	PCD-13	R	3.1.4

**1.1.1 Actor Descriptions and Actor Profile Requirements**

245 Normative requirements are typically documented in Volume 2 (Transactions) and Volume 3  
 (Content Modules). Some Integration Profiles, however, contain requirements which link  
 transactions, data, and/or behavior. Those Profile requirements are documented in this section as  
 normative requirements (“shall”).

**1.1.1.1 RDC**

250 The Retrospective Data Consumer (RDC) initiates the query for retrospective data, initiating  
 such query with the PCD-12 transaction. The RDC is understood to begin with a human, clinical  
 request which is then translated into one or more requests for data to one or more Retrospective  
 Data Responders (RDRs) available within the environment. The environment of RDRs is  
 understood to mean those within proximity to the RDC, to which the RDC has online access.  
 255 Therefore, RDRs are understood to be those systems that provide on-line and ready access to  
 retrospective data.

**1.1.1.2 RDR**

The Retrospective Data Responder (RDR) responds to queries for retrospective data, responding  
 to queries to the best of its ability for discrete data with PCD-13 transactions that are returned to  
 the RDC. The RDR is understood to provide online and ready access to PCD-12 queries.

260 **1.2 RDQ Actor Options**

Options that may be selected for this Profile are listed in the table 1.2-1 along with the Actors to  
 which they apply. Dependencies between options when applicable are specified in notes.

**Table 1.2-1: RDQ - Actors and Options**

Actor	Options	Volume & Section
RDC	N/A	Volume 2Section 3
RDR	N/A	Volume 2 Section 3

265 **1.3 RDQ Actor Required Groupings**

Not applicable.

**1.4 RDQ Overview**

**1.4.1 Concepts**

270 **1.4.2 Use Case #1: Query for all retrospective data on a single patient.**

#### **1.4.2.1 RDQ Use Case Description**

275 Scenario: Consider a patient in critical care unit for a period of time (perhaps several hours to several days). A clinician requests history of all patient-specific physiologic data from time patient arrived in critical care unit to current time. This, start time is time of arrival in unit in the past. Hence, start time reflects the time in the past (wildcard) current time. Result of query is summary of all cross-device data available on patient for presentation in some user interface in either columnar or graphical (trending) format. The diagram of Figure 1.4.2.2-1 is the reference diagram for this use case.

#### **1.4.2.2 RDQ Process Flow**

280 The query is typically initiated from and by either a clinical information system (CIS) or a clinical decision support system (CDSS) in which the RDC queries for retrospective data on at least one patient. Initiation of the query can be explicit or implicit based upon synchronizing with other data within EMR. PCD-12 transaction initiated from RDC to RDR formulated to contain request for all data in past, interpreted from time of patient arrival in unit. RDR responds to  
285 query with all available data from the time patient admitted to a room and bed.

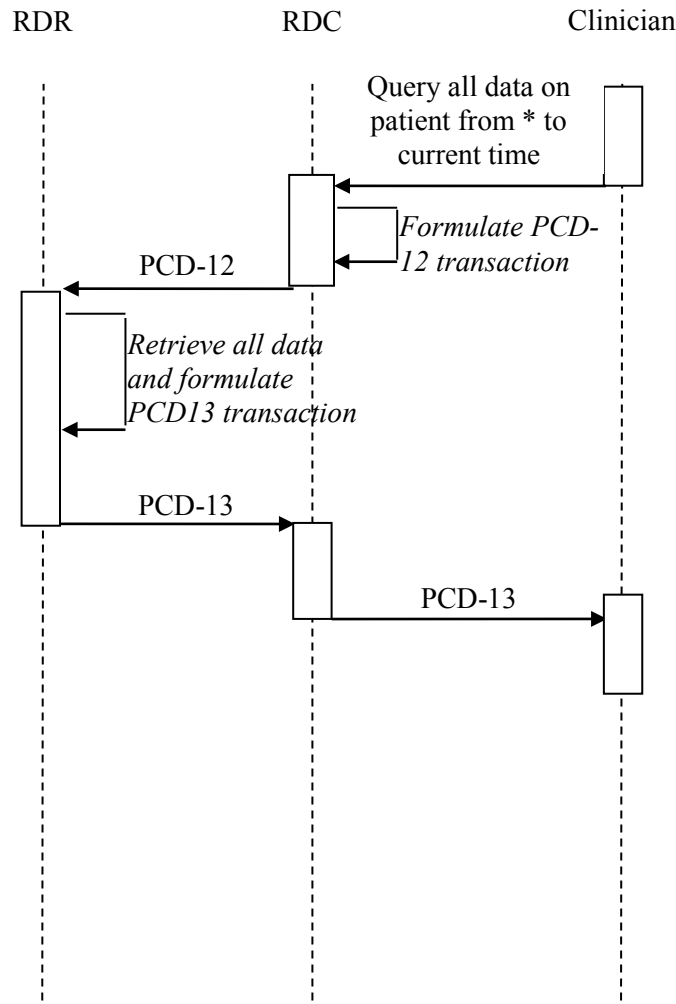

**Figure 1.4.2.2-1: Basic Process Flow in Query for all retrospective data on a single patient Profile**

290

**1.4.3 Use Case #2: Query for all retrospective data on multiple patients.**

**1.4.3.1 RDQ Use Case Description**

295

Scenario: Consider one or more patients in critical care unit for a unique period of time (perhaps several hours to several days). A clinician requests history of all patient-specific physiologic data from time patients arrived in critical care unit to current time. This request may initiate for any of a number of reasons. For instance, to assess the onset of sepsis; to support a clinical study, etc.

300 Clinical event causes clinician to request all data from time of Event to current time. Historical data would comprise all patient-specific physiologic data from time of that Event (from time of patient arrival) to current time. Result of query is summary of all cross-device data available from the time of that specific event to the current time. The diagram of Figure 1.4.3.2-1 is the reference diagram for this use case.

**1.4.3.2 RDQ Process Flow**

305 Query initiated by clinician to RDC requesting all data on all patients from wildcard to current time. Initiation of query can be explicit or implicit based upon synchronizing with other data within EMR. PCD-12 transaction initiated from RDC to RDR formulated to contain request for all data in past, interpreted from time of patient arrival in unit. RDR responds to query with all available data from the time patients admitted to bed.

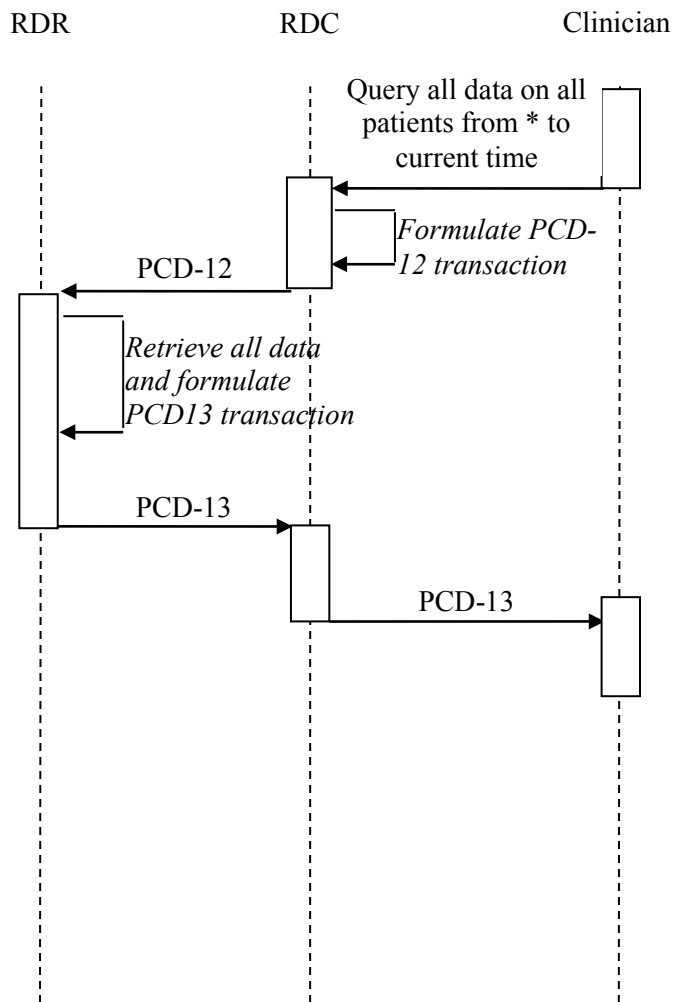

310

**Figure 1.4.3.2-1. Basic Process Flow in Query for all retrospective data on multiple patients Profile**

**1.4.4 Use Case #3: Query for retrospective data on a single patient within a specified time interval in the past.**

315 **1.4.4.1 RDQ Use Case Description**

Scenario: Consider a patient in critical care unit for a unique and defined period of time (perhaps several hours to several days). A clinician requests history of all data from this patient for this unique period of time, or time interval (t1, t2). The diagram of Figure 1.4.4.2-1 is the reference diagram for this use case.

320 **1.4.4.2 RDQ Process Flow**

Query initiated by clinician to RDC requesting all data on patient within interval (t1, t2). Initiation of query can be explicit or implicit based upon synchronizing with other data within EMR. PCD-12 transaction initiated from RDC to RDR formulated to contain request for these data in past. RDR responds to query with all available for time interval, or null if no data available.

325



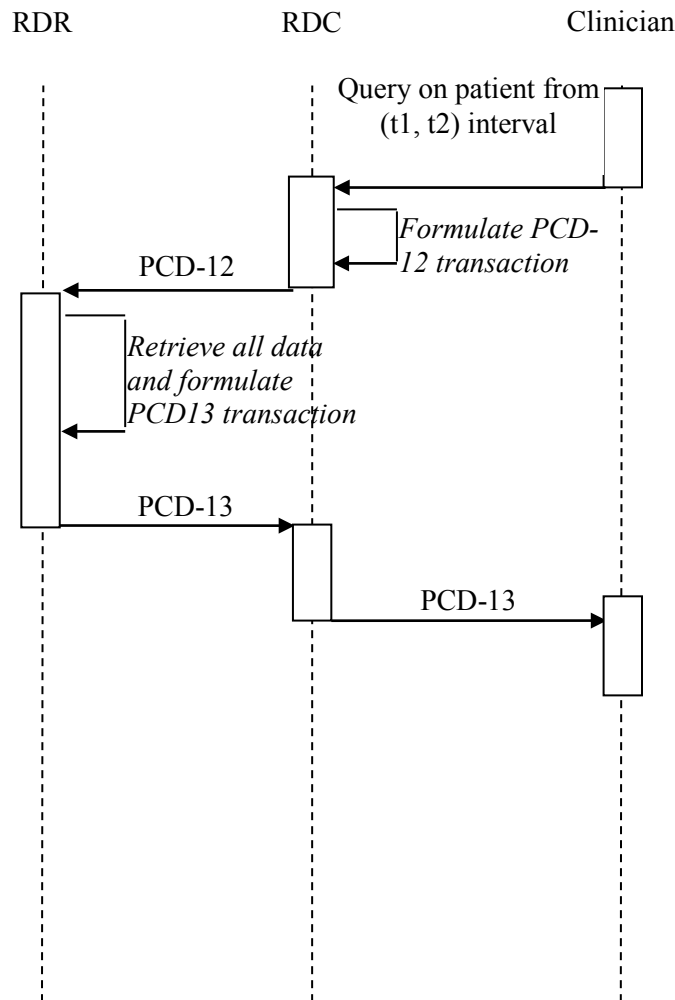

330

**Figure 1.4.4.2-1: Basic Process Flow in Query for retrospective data on a single patient within a specified time interval in the past Profile**

**1.4.5 Use Case #4: Query for retrospective data on multiple patients within a specified time interval in the past.**

**1.4.5.1 RDQ Use Case Description**

335

Scenario: Consider multiple patients in critical care unit for a unique and defined period of time (perhaps several hours to several days). A clinician requests history of all or a subset of all data from all patients for this unique period of time, or time interval (t1, t2). The diagram of Figure 1.4.5.2-1 is the reference diagram for this use case.

**1.4.5.2 RDQ Process Flow**

340 Query initiated by clinician to RDC requesting all data on all patients within interval (t1, t2).  
 Initiation of query can be explicit or implicit based upon synchronizing with other data within  
 EMR. PCD-12 transaction initiated from RDC to RDR formulated to contain request for these  
 data in past. RDR responds to query with all available for time interval, or null if no data  
 available.

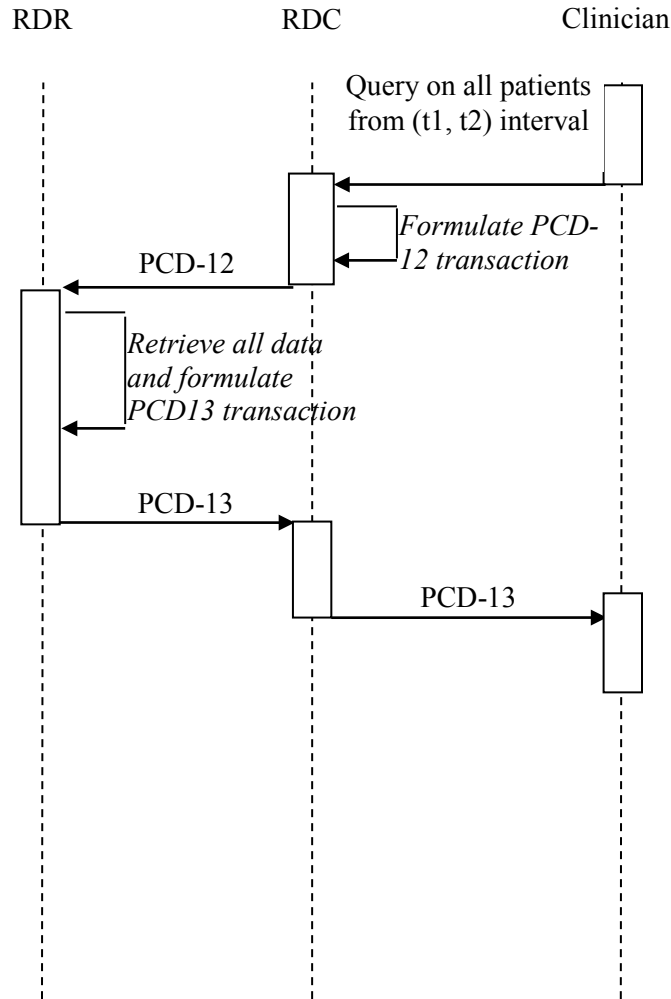

345

**Figure 1.4.5.2-1: Basic Process Flow in Query for retrospective data on multiple patients within a specified time interval in the past Profile**

**1.4.6 Use Case #5: Query for retrospective data on 1 or more parameter elements on a single patient.**

350 **1.4.6.1 RDQ Use Case Description**

Scenario: Consider a patient in critical care unit for a period of time (perhaps several hours to several days). A clinician requests history of heart rate (HR) & respiratory rate (RR) from time patient arrived in critical care unit to current time. This, start time is time of arrival in unit in the past. Hence, start time reflects the time in the past (wildcard) current time. Result of query is summary of all HR & RR data available on patient for presentation in some user interface in either columnar or graphical (trending) format. The diagram of Figure 1.4.6.2-1 is the reference diagram for this use case.

355 **1.4.6.2 RDQ Process Flow**

Query initiated by clinician to RDC requesting HR & RR on patient from wildcard to current time. Initiation of query can be explicit or implicit based upon synchronizing with other data within EMR. PCD-12 transaction initiated from RDC to RDR formulated to contain request for all HR & RR data in past, interpreted from time of patient arrival in unit. RDR responds to query with all available HR & RR data from the time patient admitted to bed.

365

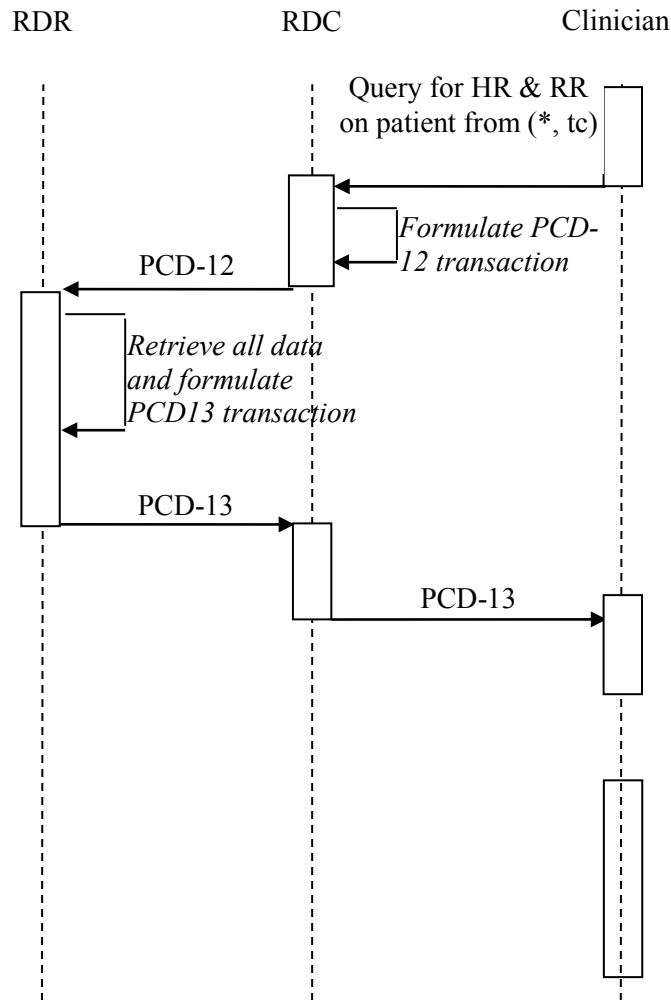

Figure 1.4.6.2-1. Basic Process Flow in Query for retrospective data on 1 or more parameter elements on a single patient for all time in the past Profile

370

**1.4.7 Use Case #6: Query for retrospective data on 1 or more parameter elements on multiple patients.**

**1.4.7.1 RDQ Use Case Description**

375

Scenario: Consider a patient in critical care unit for a period of time (perhaps several hours to several days). A clinician requests history of HR & RR data on all patients from time since they arrived in critical care unit to current time. This, start time is time of arrival in unit in the past. Hence, start time reflects the time in the past (wildcard) current time. Result of query is summary of HR & RR data available on multiple patients for presentation in some user interface in either

380 columnar or graphical (trending) format. The diagram shown in Figure 1.4.7.2-1 is the reference  
 385 diagram for this use case.

**1.4.7.2 RDQ Process Flow**

Query initiated by clinician to RDC requesting all HR & RR data on patient from wildcard to  
 current time on all patients. Initiation of query can be explicit or implicit based upon  
 385 synchronizing with other data within EMR. PCD-12 transaction initiated from RDC to RDR  
 formulated to contain request for data in past, interpreted from time of patients’ arrivals in unit.  
 RDR responds to query with all available data from the time patient admitted to bed.

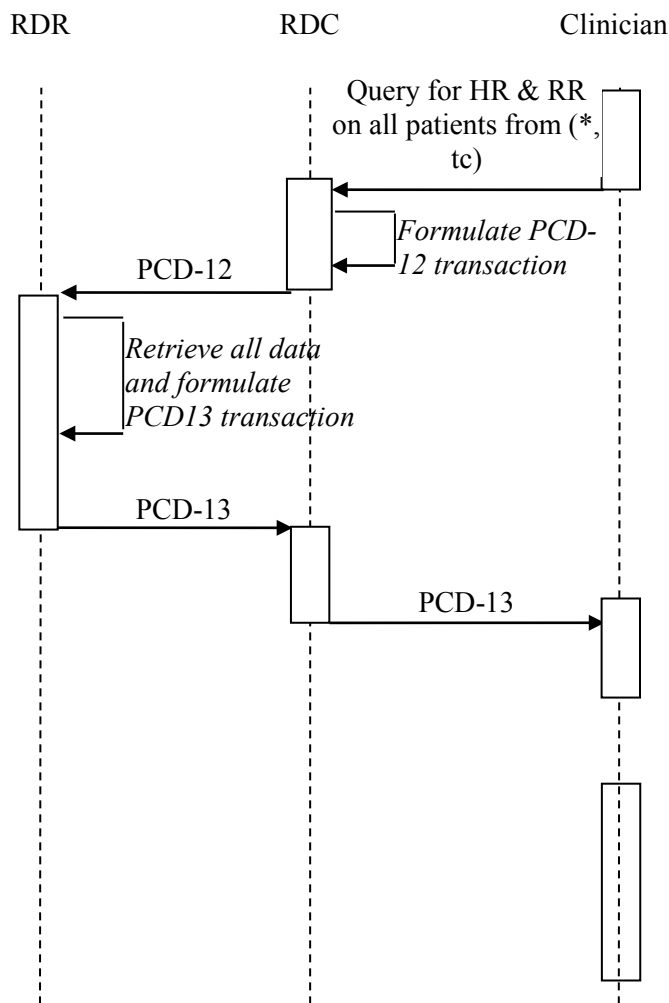

**Figure 1.4.7.2-1: Basic Process Flow in Query for retrospective data on 1 or more parameter elements on multiple patients for all time in the past Profile**

390

**1.4.8 Use Case #7: Query for retrospective data on 1 or more parameter elements on a single patient within a specified time interval in the past.**

**1.4.8.1 RDQ Use Case Description**

395 Scenario: Consider a patient in critical care unit for a period of time (perhaps several hours to several days). A clinician requests history of HR & RR data on one patient for time interval (t1, t2). The diagram of Figure 1.4.8.2-1 is the reference diagram for this use case.

**1.4.8.2 RDQ Process Flow**

400 Query initiated by clinician to RDC requesting all HR & RR data on patient for time interval (t1, t2). Initiation of query can be explicit or implicit based upon synchronizing with other data within EMR. PCD-12 transaction initiated from RDC to RDR formulated to contain request for specific data in past, from t1 to t2

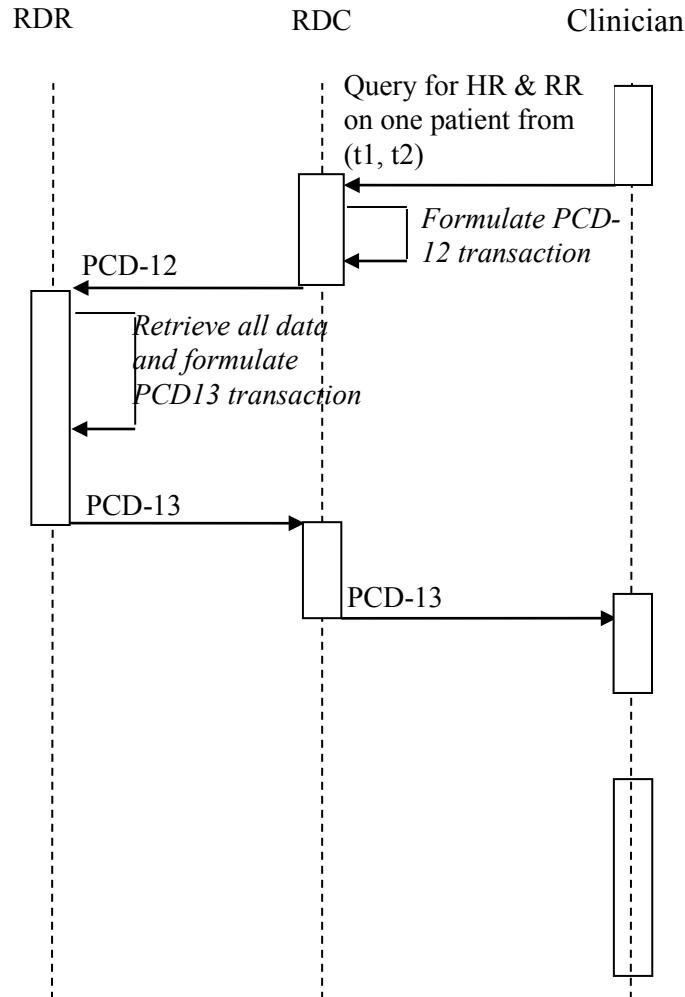

405

**Figure 1.4.8.2-1. Basic Process Flow in Query for retrospective data on 1 or more parameter elements on a single patient within a specified time interval in the past Profile**

410 **1.4.9 Use Case #8: Query for retrospective data on 1 or more parameter elements on multiple patients within a specified time interval in the past.**

**1.4.9.1 RDQ Use Case Description**

Scenario: Consider multiple patients in critical care unit for a period of time (perhaps several hours to several days). A clinician requests history of HR & RR data on all patients for time interval (t1, t2). The diagram of Figure 1.4.9.2-1 is the reference diagram for this use case

415

**1.4.9.2 RDQ Process Flow**

Query initiated by clinician to RDC requesting all HR & RR data on all patients for time interval (t1, t2). Initiation of query can be explicit or implicit based upon synchronizing with other data within EMR. PCD-12 transaction initiated from RDC to RDR formulated to contain request for specific data in past, from t1 to t2.

420

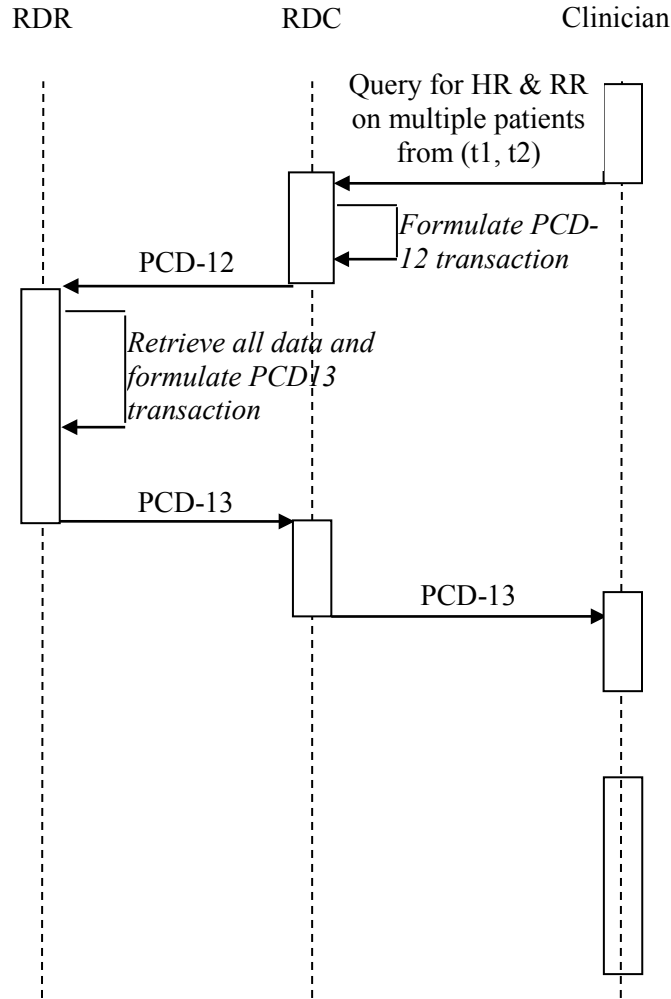

**Figure 1.5.9.2-1. Basic Process Flow in Query for retrospective data on 1 or more parameter elements on a single patient within a specified time interval in the past Profile**

425 **1.5 RDQ Security Considerations**

This profile does not impose specific requirements for authentication, encryption, or auditing, leaving these matters to site-specific policy or agreement.



## **1.6 RDQ Cross Profile Considerations**

Not applicable.

430

## Appendices

### 435 **Appendix A: Actor Summary Definitions**

#### **RDC**

440 The Retrospective Data Consumer (RDC) initiates the query for retrospective data, initiating such query with the PCD-12 transaction. The RDC is understood to begin with a human, clinical request which is then translated into a request for data to Retrospective Data Responders (RDRs) available within the environment. The environment of RDRs is understood to mean those within proximity to the RDC, to which the RDC has online access. Therefore, RDRs are understood to be those systems that provide ready, real-time access to retrospective data.

#### **RDR**

445 The Retrospective Data Responder (RDR) responds to queries for retrospective data, responding to queries for discrete data with PCD-13 (RQR) transactions that are returned to the RDC. The RDR is understood to provide online and ready access to PCD-12 queries.

### **Appendix B: Transaction Summary Definitions**

<b>Actors</b>	<b>Transactions</b>	<b>Optionality</b>	<b>Section in Vol. 2</b>
RDC	PCD-12	R	3.1.4
RDR	PCD-13	R	3.1.4

450

## Glossary

*Add the following terms to the IHE Technical Frameworks General Introduction Glossary:*

- RDC: Retrospective Data Consumer
- 455 RDR: Retrospective Data Responder
- RDQ: Retrospective Data Query, or PCD-12
- RQR: Retrospective Query Response, or PCD-13

## Volume 2 – Transactions

460 *Add section 3.1*

### 3.1 Retrospective Data Query [PCD-12]

This section corresponds to Transactions PCD-12 and PCD-13 of the IHE Patient Care Device Technical Framework. Transaction PCD-12 is used by the Retrospective Data Consumer actor to communicate a Retrospective Data Query to the Retrospective Data Responder actor. The Retrospective Data Responder then responds by transmitting a Retrospective Data Request to the Retrospective Data Consumer actor.

#### 3.1.1 Scope

The PCD-12 transaction is used to communicate Retrospective Data Query parameters from a Retrospective Data Consumer (RDC) to a Retrospective Data Responder (RDR). The PCD-13 transaction is used to communicate the response from the RDR to the RDC.

#### 3.1.2 Use Case Roles

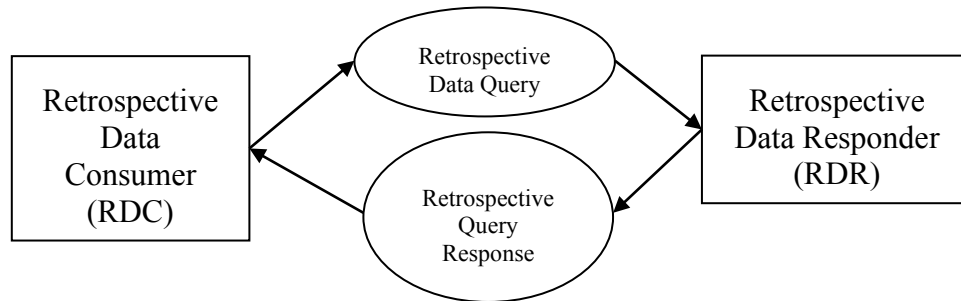

<b>Actor:</b>	<b>Retrospective Data Consumer</b>
<b>Role:</b>	The Retrospective Data Consumer (RDC) initiates the query for retrospective data, initiating such query with the PCD-12 transaction.
<b>Actor:</b>	<b>Retrospective Data Responder</b>
<b>Role:</b>	The Retrospective Data Responder (RDR) responds to the Retrospective Data Query for retrospective data with the PCD-13 transaction containing (at most) the requested data or (at minimum) a NULL indicating no such data exist.

#### 3.1.3 Referenced Standards

- 475 • HL7 – Health Level Seven Version 2.6 Ch7 Observation Reporting

- HL7 – Health Level Seven Version 2.6 Ch5 Query
- ISO/IEEE 11073-10101 Nomenclature
- Patient Demographics Query  
[http://www.ihe.net/Technical\\_Framework/upload/IHE\\_ITI\\_Patient\\_Demo\\_Query\\_2004\\_08-15.pdf](http://www.ihe.net/Technical_Framework/upload/IHE_ITI_Patient_Demo_Query_2004_08-15.pdf)

480

### 3.1.4 Interaction Diagram/ Messaging Sequence

The following interaction diagram illustrates the RDQ implementation. It is noted that the MSA acknowledgement is contained within the PCD-13 response message:

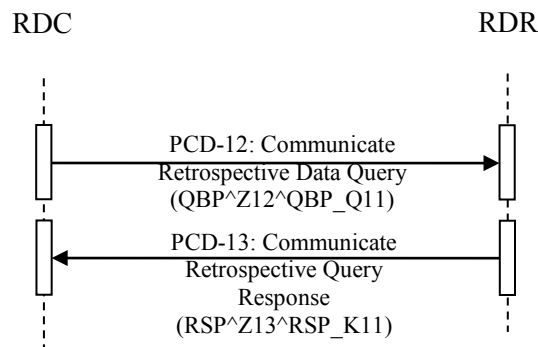

485

#### 3.1.4.1 PCD-12 Retrospective Data Query - Query Parameter Definition (QPD) Static Definition

HL7 v2.6 Chapter 5, *Section 5.4 Query/Response Message Pairs* defines three generic message structures, supported by the QBP\_Q11, QBP\_Q13, and QBP\_Q15 structured types. These types support the following specific query variants:

490

QBP_Q11	Query by Simple Parameter passes each client value to the Server positionally using only the third and successive fields of the QPD segment.
QBP_Q13	Query by Example passes parameters using HL7 segments, such as PID, that are defined in the endpoint application chapters. The third and successive fields of the PD segment also may be used in this variant.
QBP_Q15	In the QSC Selection Criteria variant, the parameter values are all contained within a single complex query selection expression that is passed in QPD-3.

The general structure for the QBP/RSP – query by parameter/segment pattern response represents the most basic type of query consistent with the objectives of the PCD-12 query command. Hence, this serves as a model for expanding the PCD-12 query and the response, PCD-13.

495 The standard QBP/RSP structure is represented as follows:

<b><u>QBP^Q11^QBP Q11</u></b>		<b><u>Query By Parameter</u></b>
	MSH	Message Header
	[{SFT}]	Software Segment
500	[ UAC ]	User Authentication Credential
	QPD	Query Parameter Definition Segment
	[	--- QBP begin
	[...]	Optional query by parameter example segments
	]	--- QBP end
505	RCP	Response Control Parameters
	[ DSC ]	Continuation Pointer

The corresponding segment pattern response (RSP) is as follows:

<b><u>RSP^K11^RSP K11</u></b>		<b><u>Segment Pattern Response</u></b>
	MSH	Message Header
	[{SFT}]	Software Segment
	[ UAC ]	User Authentication Credential
	MSA	Message Acknowledgement
515	[ ERR ]	Error
	QAK	Query Acknowledgement
	QPD	Query Parameter Definition Segment
	[	--- SEGMENT_PATTERN begin
	...	Segment Pattern from Query Profile
520	]	--- SEGMENT_PATTERN end
	[ DSC ]	Continuation Pointer

The PCD-12 Retrospective Data Query Message can be supported using these types with specific fields unique to device data queries contained within the PCD-12 QPD segment.

All HL7 segments used within the PCD-12 transaction are defined within this document.

525 The multiplicity of an actor may be greater than one; i.e., multiple RDCs may issue this request and RDRs may expect the same transaction from multiple RDCs.

Since data collected under RDQ will be used for various levels of decision support, it is crucial to have accurate patient to data association, and therefore each query is required to contain patient identifications.

530 The RDQ system (both Consumer and Responder) is interfaced to a Centralized Demographic Supplier in accordance with ITI-30 and ITI-31. This provides the knowledge at the system level to permit requests for retrieval of data associated with a patient.

Per the messaging query and response models described above, the message definitions for the RDQ and RDQ Response are specified in Tables 3.1.4.1-1 and 3.1.4.1-2, respectively.

535

**Table 3.1.4.1-1: RDQ Definition (QBP^Z12^QBP\_Q16)**

Segment	Meaning	Usage	Cardinality
MSH	Message Header	R	[1..1]
[SFT]	Software Segment	O	[0..1]
QPD	Query Parameter Definition	R	[1..1]
RCP	Response Control Parameters	R	[1..1]
DSC	Continuation Pointer	X	[0..0]

**Table 3.1.4.1-2: RDQ Response Definition (RSP^Z13^RSP\_K16)**

Segment	Meaning	Usage	Cardinality
MSH	Message Header	R	[1..1]
[SFT]	Software Segment	O	[0..1]
MSA	Message Acknowledgement	R	[1..1]
[ERR]	Error	O	[0..1]
QAK	Query Acknowledgement	R	[1..1]
[{	--- PATIENT begin	O	[0..*]
PID	Patient Identification	R	[1..1]
PV1	Patient Visit	R	[1..1]
[{	--- RESULTS begin	R	[0..*]
OBR	Observation	R	[1..1]
OBX	Observation Result	R	[1..*]
}}	--- RESULTS end	X	
}}	--- PATIENT end	X	

540 The QPD structure of the Response is described by the field fields contained in Tables 3.1.4.1-3, with definitions provided in Table 3.1.4.1-4, respectively. The QPD stricter may be appended to include additional fields in the future to enhance query precision (e.g.: Patient Name, DOB, etc.)

**Table 3.1.4.1-3: Parameters for RDQ query parameter definition (QBP^Q16) table.**

Field Seq (Query ID=Z12)	ColName	LEN	DT	Opt	RP/#	Segment Field Name	Element Name
1	MessageQueryName	250	CWE	R	[1..1]		Message Query Name
2	QueryTag	32	ST	R	[1..1]		Query Tag
3	Patient Identifier List		CX	R	[0..*]	PID.3	
4	Data Class		ST	O	[0..3]		
5	PatientLocation		PL	O	[1..*]	PV1.3	
6	ParameterClass		CWE	O	[1..*]	OBX.3	
7	StartDateTime		DTM	O	[0..1]	OBX.7	
8	EndDateTime		DTM	O	[0..1]	OBX.8	
9	Interval		CQ	O	[0..1]		
10	DeviceSettings		ST	O	[0..*]		
11	DeviceStatus		ST	O	[0..*]		

545

**Table 3.1.4.1-4: RDQ parameters definition table.**

Input Parameter (Query ID=Z12)	Type	Description
MessageQueryName	CWE	Must be valued <b>Z12^PCD-12</b> .
QueryTag	ST	Unique to each query message instance.
Patient Identifier List	CX	N MRN (PID.3) identifiers are optional
PatientLocation	PL	PV1.3, at most one per Query, is optional. Must belong to the same patient as PID.3. If null all locations match. Any components in the PL that are null will match all values in that component.
Data Class	IS	When a list is provided, results will be sent if any parameter matches OBX.3 or any result. Sending no value matches all results. Possible enumerated values include T,W,A (Trend, Waveform, Alarm).
ParameterClass	CWE	When a list is provided, results will be sent. If any parameter matches OBX.3 for any result... Sending no value matches all results.
StartDateTime	DTM	The date/time at which the query is to start. This field can represent Date/Time in the past. (time of earliest result you want) If null, retrieve as old as is available. If start and end time are the same then return the closest data sample just prior to current time.
EndDateTime	DTM	The date/time at which the query is to end. This field can represent Date/Time in the past. (time of latest result) If null, assume up until present.



Input Parameter (Query ID=Z12)	Type	Description
Interval	CQ	The requested interval between observations to be reported. If the responder cannot support this interval, it will use the nearest interval that it is capable of providing
DeviceStatus	IS	Controls whether device status data items are requested to be included in the response. Valid values are “Y” to include the data items, “N” to exclude them. If field is left empty, the data items will be included.
DeviceSettings	IS	Controls whether device settings data items are requested to be included in the response. Valid values are “Y” to include the data items, “N” to exclude them. If field is left empty, the data items will be included.

#### 3.1.4.1.1 Managing the Size of Responses

Depending on the duration of patient stay, the density of the data, quantity of data to be retrieved, and interval of data to be retrieved, the resultant response can be rather large. In discussions internal to the working group it was decided that it would be appropriate to make use of the query acknowledgement as well as start and stop times in the OBR segments to provide an indicator of just where in the sequence a data response is when returned to the RDC. RQR messages may be large and, as such, may be broken into (many) multiples of message segments. Hence, the PCD-13 “message” delivered by the RDR may have many parts and be delivered as separate message segments to the RDC. The HL7 v2.6 Specification, Chapter 5, provides a description of an approach using the query acknowledgement (QAK) to indicate when the PCD-13 is complete. In the example provided in Table 3.1.4.1-6, the OBR segment illustrates this approach by displaying the current time interval together with the time interval of the last message. Furthermore, the QAK segment also provides an indication as to whether the returned PCD-13 is complete.

#### 3.1.4.1.2 Obtaining All the Data

Data for a specific patient or for all patients may be distributed across a number of archives. The RDC is responsible for issuing PCD-12 requests to each archive individually. For example if the RDC wants data from all patients in a hospital, and the data from those patients is located in 3 archives, it will need to issue PCD-12 requests and will receive independent responses from those 3 archives.

#### 3.1.4.1.3 Example - Query per Parameter per Patient

Assumptions: We assume that the RDQ system (both Consumer and Responder) is interfaced to a Centralized Demographic Supplier in accordance with ITI-30 and ITI-31. This provides the knowledge at the system level to permit requests and retrieval of data associated with a patient.

In addition, the RDC can have a user interface through which patient data can be entered manually in order to perform queries related to a specific patient.

[TBR] This query assumes that a specific parameter can be queried and all data associated with this parameter over some time frame will be returned. Example parameter list consisting of pulse, O2 saturation, and respiratory rate supplied. Note: MSH21 is required in all (OID).

Table 3.1.4.1-5 below is an example Query by parameter per patient. Table 3.1.4.1-6 contains the resultant for this query for all parameters associated with a given patient. The RPC segment indicates that this is an immediate request for real time data. In the response to this query, the model is adopted that each time-dated set of responses within the resultant response transaction will be separated by OBR per time span for a given patient. Furthermore, use of the QAK segment per the standard query response contained in HL7 v2.6 section 5.4 will provide continuation pointers indicating the end of a response transaction. Use the QAK in 5.4 HL7.

Assumptions: no communication of parameters in vector format is supported in the current trial implementation (i.e., waveforms). The response adheres to the model of multiple OBR segments, with each OBR segment representing a separate and unique timeframe associated with the set of parameters requested in multiple OBX segments for a single query.

Note that the examples are intended to illustrate the general form, and some details, of the HL7 messages, rather than to serve as complete or rigorous models to be copied verbatim. The authoritative source for details of segments and fields, is the latest version of the PCD Technical Framework Volume 2; where there is disagreement between the examples and the Technical Framework, the Technical Framework should be followed. When the contents of a field are surrounded by exclamation marks, like !PV1.3!, they are an explanation or indication of the source of the data in the field, rather than what the actual contents would be. So !PV1.3! indicates that the field should contain patient location information from the PV1.3 field that would identify the location of the patients that are the subject of the query.

**Table 3.1.4.1-5: Example of PCD-12 Query per patient per parameter for trend data (T). This query is a request for ALL historical data available on the parameters heart rate, arterial blood pressure, and respiratory rate.**

```
MSH|^~\&|RDQ_REQUESTER|REQUESTER_SITE|RDQ_SERVER_GATEWAY|SERVER_SITE|
201101030819000-0500||QSB^Z12^QSB_Q16||P|2.6|||NE|AL||||
IHE_PCD_012^IHE_PCD^1.3.6.1.4.1.19376.1.6.1.12.1^
PD|Z12^PCD-12||T|!PV1.3!|147842^MDC_ECG_HEART_RATE^MDC~150035^
MDC_PRESS_BLD_ART_MEAN^MDC~150033^MDC_PRESS_BLD_ART_SYS^MDC
~150034^MDC_PRESS_BLD_ART_DIA^MDC~151610^MDC_VENT_CO2_RESP_RATE^MDC
RCP|I||R
```

The result in Table 3.1.4.1-6 follows the model of Table 3.1.4.1-2. Of note is the interleaving of historical data: In the sample query of Table 3.1.4.1-5, a request is made for historical data on 5 parameters for a specific patient:

```
<component> 147842^MDC_ECG_HEART_RATE^MDC</component>
<component> 150035^MDC_PRESS_BLD_ART_MEAN^MDC</component>
<component> 150033^MDC_PRESS_BLD_ART_SYS^MDC</component>
<component> 150034^MDC_PRESS_BLD_ART_DIA^MDC</component>
<component> 151610^MDC_VENT_CO2_RESP_RATE^MDC</component>
```

610 In the response, each OBR indicates through the OBR.7 and OBR.8 fields, respectively, the time of the current values (OBR.7) and the last data time/date stamp (OBR.). If the last data are available at current time, then the last OBR will have the OBR.7 & OBR.8 values equal.

In the limit of only a single OBR and single set of parameter values, the resultant PCD-13 transaction will appear very similar to the PCD-01 result.

**Table 3.1.4.1-6: Example PCD-13 response for request per patient per parameter.**

<pre> MSH ^~\&amp; RDQ_REQUESTER REQUESTER_SITE RDQ_SERVER_GATEWAY SERVER_SITE 201101030819- 0500  QSB^Z12^QSB_Q12 10004 P 2.6   NE AL   IHE_PCD_13^IHE_PCD^1.3.6.1.4.1.19376.1.6.1 .13.1 MSA AA 1004 QAK QueryTag001 PID  PV1  OBR 1   182777000^monitoring of patient^SCT   20120414120101 20120414130101 OBX 1 NM 14782^MDC_ECG_HEART_RATE^MDC 1.6.1.1 60 /min^/min^UCUM    R      123456^ICU_MONITOR^megacorp.com^DNS OBX 2 NM 150035^MDC_PRESS_BLD_ART_MEAN^MDC 1.3.1.1 92 {mm[Hg]}^{mm[Hg]}^UCUM    R      123456^ICU_MONITOR^megacorp.com^DNS OBX 3 NM 150033^MDC_PRESS_BLD_ART_SYS^MDC 1.3.1.2 120 {mm[Hg]}^{mm[Hg]}^UCUM    R      123456^ICU_MONITOR^megacorp.com^DNS OBX 4 NM 150034^MDC_PRESS_BLD_ART_DIA^MDC 1.3.1.3 80 {mm[Hg]}^{mm[Hg]}^UCUM    R      123456^ICU_MONITOR^megacorp.com^DNS OBX 5 NM 151610^MDC_VENT_CO2_RESP_RATE^MDC 1.3.1.1 60 {{breath}}/min^UCUM    R      123456^ICU_MONITOR^megacorp.com^DNS  ... Note: observation groups between first and last omitted. Last observation group follows:  OBR N   182777000^monitoring of patient^SCT   20120414130101 20120414130101 OBX 1 NM 14782^MDC_ECG_HEART_RATE^MDC 1.6.1.1 60 /min^/min^UCUM    R      123456^ICU_MONITOR^megacorp.com^DNS OBX 2 NM 150035^MDC_PRESS_BLD_ART_MEAN^MDC 1.3.1.1 92 {mm[Hg]}^{mm[Hg]}^UCUM    R      123456^ICU_MONITOR^megacorp.com^DNS OBX 3 NM 150033^MDC_PRESS_BLD_ART_SYS^MDC 1.3.1.2 120 {mm[Hg]}^{mm[Hg]}^UCUM    R      123456^ICU_MONITOR^megacorp.com^DNS OBX 4 NM 150034^MDC_PRESS_BLD_ART_DIA^MDC 1.3.1.3 80 {mm[Hg]}^{mm[Hg]}^UCUM    R      123456^ICU_MONITOR^megacorp.com^DNS OBX 5 NM 151610^MDC_VENT_CO2_RESP_RATE^MDC 1.3.1.1 60 {{breath}}/min^UCUM    R      123456^ICU_MONITOR^megacorp.com^DNS </pre>
---

615 Several variants to the query by patient by parameter scenario exist. In this example, queries for several parameters over all time in the past (that is, any existing data on specified parameters) resulted in the retrieval of all available data on the specific patient. In general, if a query field is not specified explicitly, the interpretation is that of a wild card: i.e., return all available. This model applies to the situation wherein patient identifier is not specified, as well. In this situation,

620 if no patient identifier is explicitly shown, then parameter data on all patients would be returned, subject to other restrictions in the query.

The most general of queries would involve retrieving all available data on all patients, achieved by removing patient identifiers and parameter list from the query. On the other hand, the most restrictive of queries would contain patient identifier, parameter identifiers, and time frame for query retrieval.

625 The general structure of the query will be as given in Table 3.1.4.1-1. The specific changes to the QPD segment in Table 3.1.4.1-3 are where the variants are expressed. An example of the query variation is described in each of the variants.

**3.1.4.1.4 Example - Query per Time Frame per Patient**

630 To provide a further illustration, consider Query per Time Frame per Patient. This query assumes that a request for all data within a given time frame be made, and all data from all patients (associated with each patient individually) will be returned. If no start date /& time specified (blank), assumption is retrieve earliest possible. If no end date & time specified, assumption is retrieve all data from start date & time to current. In this example, QPD.8 and QPD.9 are valued

635 with the time interval for the data request, as shown in Table 3.1.4.1-7. The entry for QPD.8 is the farthest time in the past and QPD.9 is the closest to current time. As in the preceding example, if these fields are left blank, ALL prior data found will be retrieved.

**Table 3.1.4.1-7: Query per time frame per patient sample query.**

MSH ^~\& RDQ_REQUESTER REQUESTER_SITE RDQ_SERVER_GATEWAY SERVER_SITE 201101030819000-0500  QSB^Z12^QSB_Q16  P 2.6   NE AL   IHE_PCD_012^IHE PCD^1.3.6.1.4.1.19376.1.6.1.12.1^ISO
QPD Z12^PCD-12  T !PIV1.3!   201204101300 201204101300
RCP I  R

640 **3.1.4.1.5 Example - Query per Parameter per Patient per Interval**

A final example involves specifying the sampling frequency of data, using the QPD.10 field. The sampling frequency query requests data will be retrieved at the interval specified, beginning with the start time of the query and proceeding up until current time or until the last parameter value is found. The query operates on a “best-effort” basis to retrieve data in the specified frequency. For example, if retrieval of heart rate is requested at an interval of 10 seconds, then the result would be all historical data retrieved on a 10 second interval, where available, beginning with the time of initial query in the past up through current time. This is illustrated in Table 3.1.4.1-8. In this example heart rate is requested in 10 second intervals beginning on April 10<sup>th</sup>, 2012 at 1300 hours up to and including May 14<sup>th</sup>, 2012 at 1300 hours. If the data exist and meet the specified

645 criteria, then they will be returned in this interval.

**Table 3.1.4.1-8: Query by parameter by patient with requested sampling frequency.**

MSH ^~\& RDQ_REQUESTER REQUESTER_SITE RDQ_SERVER_GATEWAY SERVER_SITE 201101030819000-0500  QSB^Z12^QSB_Q16  P 2.6  NE AL   IHE_PCD_012^IHE PCD^1.3.6.1.4.1.19376.1.6.1.12.1^ISO
QPD Z12^PCD-12 QUERYTAG003 !PID. T !PIV1.3!  201204101300 201204101300 10
RCP I  R

655 **3.1.5 Security Considerations**

This profile does not impose specific requirements for authentication, encryption, or auditing, leaving these matters to site-specific policy or agreement.

660

## **Volume 3 – Content Modules**

Not applicable.

665

## **Volume 4 – National Extensions**

670 Not applicable; no National Extensions defined to date.