

**Integrating the Healthcare Enterprise**



**IHE Eye Care  
Technical Framework Supplement**

**Basic Eye Care Workflow  
(B-EYECARE)**

**Trial Implementation**

Date: March 31, 2011  
Author: IHE Eye Care Domain  
Email: [eyecare@ihe.net](mailto:eyecare@ihe.net)

## Foreword

This is a supplement to the IHE Eye Care Technical Framework V3.7. Each supplement undergoes a process of public comment and trial implementation before being incorporated into the volumes of the Technical Frameworks.

This supplement is submitted for Trial Implementation as of March 31, 2011 and will be available for testing at subsequent IHE Connectathons. The supplement may be amended based on the results of testing. Following successful testing it will be incorporated into the Eye Care Technical Framework. Comments are invited and may be submitted on the IHE forums at <http://forums.rsna.org/forumdisplay.php?f=11> or by email to [eyecare@ihe.net](mailto:eyecare@ihe.net).

This supplement describes changes to the existing technical framework documents and where indicated amends text by addition (**bold underline**) or removal (**~~bold strikethrough~~**), as well as addition of large new sections introduced by editor's instructions to "add new text" or similar, which for readability are not bolded or underlined.

"Boxed" instructions like the sample below indicate to the Volume Editor how to integrate the relevant section(s) into the relevant Technical Framework volume:

<i>Replace Section X.X by the following:</i>
--

General information about IHE can be found at: [www.ihe.net](http://www.ihe.net)

Information about the IHE Eye Care can be found at: <http://www.ihe.net/Domains/index.cfm>

Information about the structure of IHE Technical Frameworks and Supplements can be found at: <http://www.ihe.net/About/process.cfm> and <http://www.ihe.net/profiles/index.cfm>

The current version of the IHE Technical Framework can be found at: [http://www.ihe.net/Technical\\_Framework/index.cfm](http://www.ihe.net/Technical_Framework/index.cfm)

## CONTENTS

Introduction.....	4
Profile Abstract .....	4
Open Issues and Questions .....	4
Closed Issues .....	4
<b>Volume 1 – Integration Profiles.....</b>	<b>5</b>
1.7 History of Annual Changes .....	5
1.n Copyright Permission.....	5
2.1 Dependencies among Integration Profiles .....	5
2.2.5 Basic Eye Care Workflow Integration Profile .....	6
2.3 Actors Descriptions.....	7
2.4 Transaction Descriptions.....	8
2.5 Product Implementations .....	9
7 Basic EYE CARE Workflow (B-EYECARE) .....	10
7.1 Actors/Transactions .....	10
7.2 Basic Eye Care Workflow Integration Profile Options .....	12
7.2.1 Implementation of Transactions Defined in Advanced Eye Care Integration Profile.....	13
7.2.2 Acquisition Modalities Storage Options .....	14
7.2.3 Acquisition Modality Importer Storage .....	14
7.3 Basic Eye Care Workflow Process Flow.....	15
7.3.1 Extension to Query Modality Worklist for Eye Care [EYECARE-1] .....	16
7.4 Basic Eye Care Workflow Use Cases .....	17
7.4.1 Workflow Example with Manual Procedure Order .....	17
7.4.2 Workflow Where the Procedure Ordered is an Automatic Eye Care Order.....	18
7.5 Workflow Concepts in Practice.....	18
7.6 Patient Reconciliation Use Case.....	20
7.7 Workflow Use Cases .....	21
X.4 <Profile Name> Security Considerations.....	21
Glossary .....	22
<b>Volume 2 - Transactions.....</b>	<b>23</b>

## Introduction

Introduce a new Eye Care integration profile Basic Eye Care Workflow (B-EYECARE). Updates to Volume 1 section 2 to include new integration profile B-EYECARE and added new section 7. Updates to Volume 2, text in various sections of 4.2 related to PDF/A requirements.

## Profile Abstract

Implementation experience has shown the eye care community that integration of patient and procedure data between EHR's (typically Order Fillers) and Instruments (Acquisition Modalities) is the main and most important transaction between the two actors. This is accomplished by DICOM Modality Worklist

Transactions based on DICOM Modality Performed Procedure Step and Storage Commitment are useful in a completely integrated system, but are not easily understood by users and not typically requested. Therefore, IHE Eye Care decided to create the Basic Eye Care Workflow Integration Profile.

Basic Eye Care Workflow Integration Profile establishes the continuity and integrity of basic patient and procedure data in the context of an eye clinic and/or an integrated hospital workflow scenario. This profile is a subset of the features defined in the Advanced Eye Care Workflow Integration profile.

Additionally, non-DICOM install base acquisition modality implementations have often been providing PDF solutions. Migration to the PDF/A standard is a difficult and costly upgrade for the installed base therefore we modified the requirement to a recommendation.

Note: Implementations that support the Basic Eye Care Workflow profile may also support transactions defined in the Advanced Eye Care Workflow but not the complete list of required features. For example, an Acquisition Modality may choose to support DICOM Storage Commitment but not Modality Performed Procedure Step. Or they could choose to implement the Stereo Relationship Option.

The Basic Eye Care Workflow Integration Profile has been integrated with the Patient Administration Management (PAM) profile created by IHE ITI.

## Open Issues and Questions

No open questions at this time.

## Closed Issues

No issues at this time.

# Volume 1 – Integration Profiles

## 1.7 History of Annual Changes

*Add the following bullet to the end of the bullet list in section 1.7*

Added the Basic Eye Care Workflow Integration Profile. B-EYECARE establishes the continuity and integrity of basic patient and procedure data in the context of an eye clinic and/or an integrated hospital workflow scenario. This profile is a subset of the features defined in the Advanced Eye Care Workflow Integration profile.

The Basic Eye Care Workflow Integration Profile is synchronized with the IHE ITI Patient Administration Management Profile (PAM) which includes actors Patient Demographics Supplier and Patient Demographics Consumer.

## 1.n Copyright Permission

No changes.

*Add the following to sections 1.n:*

## 2.1 Dependencies among Integration Profiles

*Add the following to Figure 2-1*

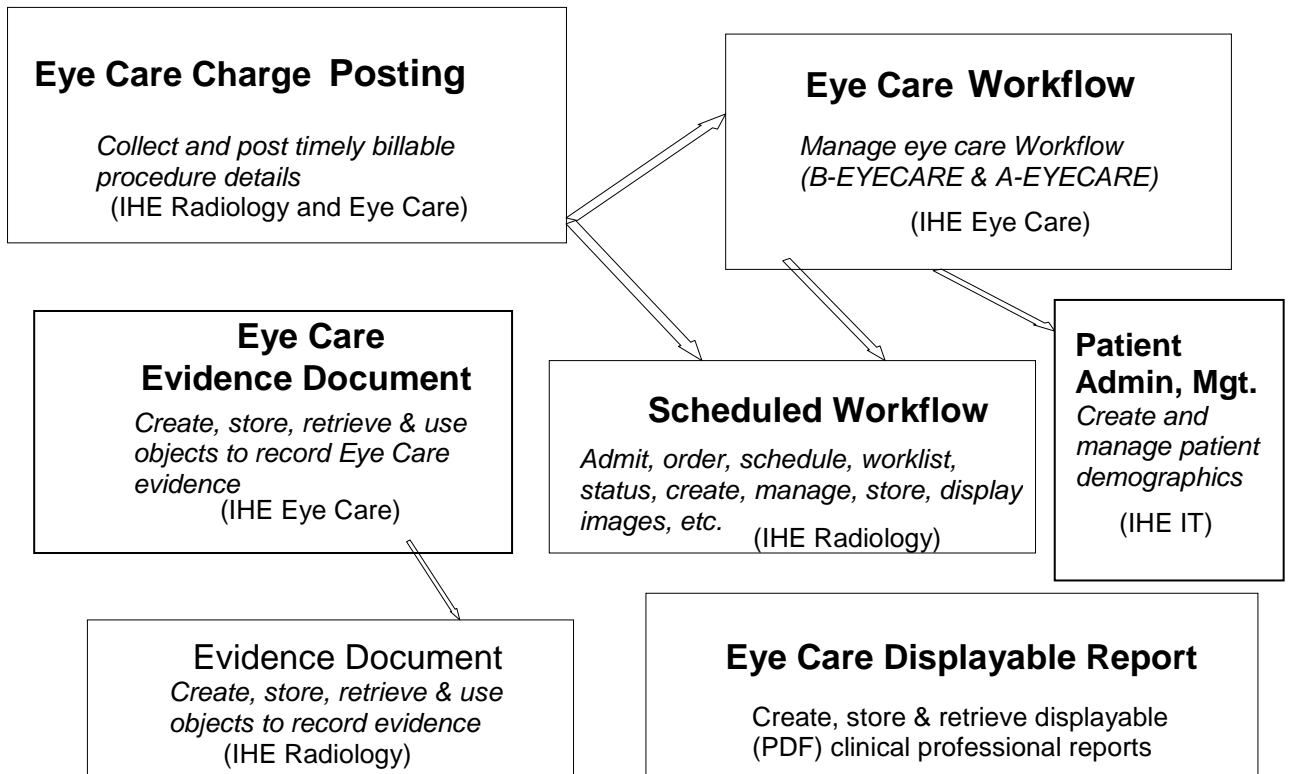

Add the following to Table 2-1

Basic Eye Care Workflow	RAD TF Scheduled Workflow ITI TF Patient Administration Management (PAM)	This profiles uses definitions from those specified	
-------------------------	--	---	--

Add the following section to section 2.2

### 2.2.5 Basic Eye Care Workflow Integration Profile

B-EYECARE addresses three workflow scenarios, standalone eye care clinics; large eye care groups and hospital-based eye care departments.

Note: We understand that others scenarios exist, i.e., eye care referrals, telemedicine, etc. However, they are not being formally addressed and will be considered in future versions.

In eye care settings, patients present with a variety of symptoms and complaints, which may or may not result in the need for diagnostic imaging and testing. Some types of imaging and testing may be performed routinely, before patients are seen by a healthcare provider. Other types of imaging and testing may be performed only after a healthcare provider has determined the need for them while examining the patient. Thus orders may be placed either manually, or automatically. This requirement of flexibility is paramount.

The Basic Eye Care Workflow Integration Profile establishes the continuity and integrity of basic patient and procedure data in the context of an eye care clinic and/or an integrated hospital workflow scenario. This profile deals specifically with consistent handling of patient identifiers and demographic data. This includes when specific procedure(s) have been manually ordered by a healthcare provider in addition to the scenario where an automatic eye care order has been placed. The automatic orders are created for procedures routinely performed on patients without a healthcare provider order and frequently prior to the patient being seen by a healthcare provider. Thus the purpose of the automatic order is not to provide legal authority for performing a procedure, but rather to provide data integrity. This profile specifies the scheduling and coordination of procedure data to a wide variety of diagnostic imaging and testing equipment.

B-EYECARE is a subset of the features defined in the Advanced Eye Care Workflow Integration profile.

### 2.3 Actors Descriptions

*Add column to table 2.3-1*

**Patient Demographics Supplier** – A system responsible for adding, updating and maintaining demographics about a patient, and additional information such as related persons (primary caregiver, guarantor, next of kin, etc.). It supplies new and updated information to the Patient Demographics Consumer.

**Patient Demographics Consumer** – A system that uses demographic information provided by the Patient Demographics Supplier about a patient.

*Add column to table 2.3-1*

**Table 2.3-1. Integration Profile Actors**

Actor	Integration Profile	Basic EYE CARE Workflow
Acquisition Modality		X
Acquisition Modality Importer		X
Charge Processor		

Integration Profile Actor	Basic EYE CARE Workflow
Department System Scheduler/Order Filler	X
Evidence Creator	X
Image Archive	X
Image Display	X
Image Manager	X
Order Placer	X
Patient Demographics Supplier	X
Patient Demographics Consumer	X
Performed Procedure Step Manager	
Report Creator	
Report Reader	
Report Repository	

## 2.4 Transaction Descriptions

*Add column to table 2.4-1*

**Patient Identity Management** – The Patient Demographics Supplier registers or updates a patient and forwards the demographic information (i.e., all information directly related to the patient, such as ID, address, next of kin, guarantor, etc.) to other systems implementing the Patient Demographics Consumer Actor.

*Add column to table 2.4-1*

**Table 2.4-1. Integration Profile Transactions**

Integration Profile Transaction	Basic EYE CARE Workflow
Patient Identity Management [ITI-30]	X
Placer Order Management [RAD-2]	X
Filler Order Management [RAD-3]	X
Procedure Scheduled [RAD-4]	X
Query Modality Worklist [EYECARE-1]	X
Modality Procedure Step In Progress [RAD-6]	

<b>Transaction</b>	<b>Integration Profile</b>	<b>Basic EYE CARE Workflow</b>
Modality Procedure Step Completed [EYECARE-6]		
Modality Images/Evidence Stored [EYECARE-2]		
Storage Commitment [CARD-3]		
Patient Update [RAD-12]		<b>X</b>
Procedure Update [RAD-13]		<b>X</b>
Query Images [EYECARE-5]		<b>X</b>
Retrieve Images [EYECARE-3]		<b>X</b>
Charge Posted [RAD-35]		
Account Management [RAD-36]		
Query Evidence Documents [EYECARE-4]		
Retrieve Evidence Documents [RAD-45]		
Displayable Report Storage [EYECARE-7]		
Query Displayable Report [EYECARE-8]		
Retrieve Displayable Report [EYECARE-9]		

## 2.5 Product Implementations

*Add bullets in section 2.5 to describe product actor groupings*

- A Department System Scheduler/Order Filler participating in Basic Eye Care Integration Profile shall be grouped with a Patient Demographics Consumer.
- An Order Placer participating in Basic Eye Care Integration Profile shall be grouped with a Patient Demographics Consumer.

## 7 Basic EYE CARE Workflow (B-EYECARE)

The Basic Eye Care Workflow Integration Profile establishes the continuity and integrity of basic patient and procedure data in the context of an eye clinic and/or an integrated hospital workflow scenario. This profile deals specifically with consistent handling of patient identifiers and demographic data. It also specifies the scheduling and coordination of procedure data to a wide variety of diagnostic imaging and testing equipment.

B-EYECARE is a subset of the features defined in the Advanced Eye Care Workflow Integration profile. It has much in common with the IHE Radiology Scheduled Workflow, but deals more explicitly with the eye care workflow and data requirements. See RAD TF-1: 3.4 for the integrated workflow data model adopted by the IHE Technical Framework for HL7 messages and DICOM information objects. This data model offers three major levels of control for workflow:

- **Order:** A request for a Departmental Service
- **Requested Procedure:** Unit of work resulting in one or more reports, with associated codified, billable acts.
- **Scheduled and Performed Procedure Step:** the smallest unit of work in the workflow that is scheduled (work to do) or performed (work done).

A clear understanding of the workflow data model is essential to interpreting the Eye Care Workflow Integration Profile. Additional information may be found in Appendix A and B. B-EYECARE workflow address the Order, Requested Procedure and Scheduled Procedure Step. The Performed Procedure Step is not modeled in B-EYECARE but included in A-EYECARE.

Although the major cases for eye care workflow are described in the following subsections, it is beneficial to also see the corresponding workflows in radiology. RAD TF-1: 3.3 has a description of the “normal” scheduled workflow when all three levels of control in the data model are fully utilized for known patients.

### 7.1 Actors/Transactions

Figure 7.1-1 diagrams the actors involved with this profile and the transactions between actors.

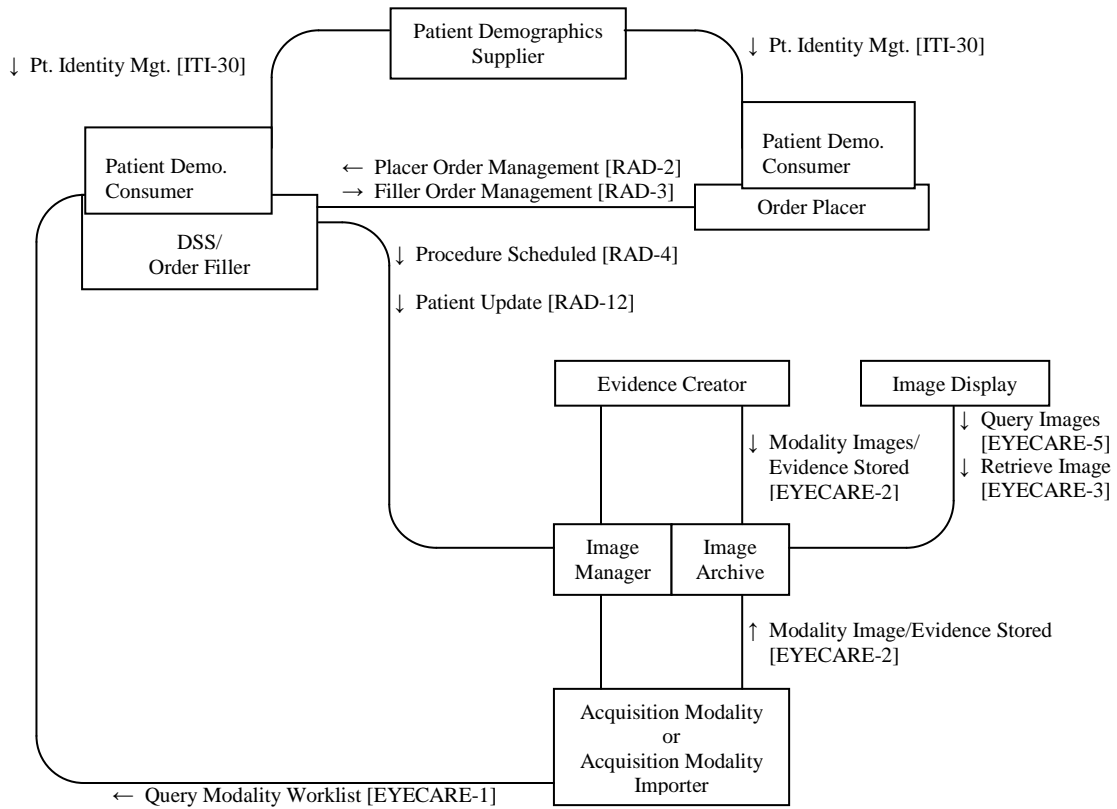

**Figure 7.1-1. Eye Care Workflow Diagram**

Note that this diagram maintains the actor and transaction names specified in the Radiology Technical Framework and Cardiology Technical Framework documents (RAD TF and CARD TF) for consistency of definitions.

Table 7.1-1 lists the transactions for each actor directly involved in the Eye Care Workflow Integration Profile. In order to claim support of this Integration Profile, an implementation must perform the required transactions (labeled “R”). Transactions labeled “O” are optional. A complete list of options defined by this Integration Profile that implementations may choose to support is listed in Section 7.2.

**Table 7.1-1. Basic Eye Care Workflow - Actors and Transactions**

Actors	Transactions	Optionality	Section
Patient Demographics Supplier	Patient Identity Management [ITI-30]	R	ITI TF-2b:3.30
Patient Demographics Consumer	Patient Identity Management [ITI-30]	R	ITI TF-2b:3.30
Order Placer	Placer Order Management [RAD-2]	R	RAD TF- 2: 4.2

Actors	Transactions	Optionality	Section
	Filler Order Management [RAD-3]	R	RAD TF- 2: 4.3
Department System Scheduler/ Order Filler	Patient Update [RAD-12]	R	RAD TF- 2: 4.12
	Placer Order Management [RAD-2]	R	RAD TF- 2: 4.2
	Filler Order Management [RAD-3]	R	RAD TF- 2: 4.3
	Procedure Scheduled [RAD-4]	R	RAD TF- 2: 4.4
	Query Modality Worklist [EYECARE-1]	R	EYECARE TF- 2: 4.1
Acquisition Modality	Query Modality Worklist [EYECARE-1]	R	EYECARE TF- 2: 4.1
	Modality Images/Evidence Stored [EYECARE-2]	R	EYECARE TF- 2: 4.2
Acquisition Modality Importer	Query Modality Worklist [EYECARE-1]	R	EYECARE TF- 2: 4.1
	Modality Images/Evidence Stored [EYECARE-2]	R	EYECARE TF- 2: 4.2
Evidence Creator	Modality Images/Evidence Stored [EYECARE-2]	R	EYECARE TF- 2: 4.2
Image Manager/ Image Archive	Procedure Scheduled [RAD-4]	R	RAD TF- 2: 4.4
	Modality Images/Evidence Stored [EYECARE-2]	R	EYECARE TF- 2: 4.2
	Patient Update [RAD-12]	R	RAD TF- 2: 4.12
	Query Images [EYECARE-5]	R	EYECARE TF- 2: 4.5
	Retrieve Images [EYECARE-3]	R	EYECARE TF- 2: 4.3
Image Display	Query Images [EYECARE-5]	R	EYECARE TF- 2: 4.5
	Retrieve Images [EYECARE-3]	R	EYECARE TF- 2: 4.3

Refer to Table 2-1 for other profiles that may be pre-requisites for this profile.

## 7.2 Basic Eye Care Workflow Integration Profile Options

Many Actors have Options defined in order to accommodate variations in use across domains or implementations. Options that may be selected for this Integration Profile are listed in Table 7.2-1 along with the Actors to which they apply.

**Table 7.2-1. Eye Care Workflow - Actors and Options**

Actor	Option Name	Optionality	Vol & Section
Patient Demographics Supplier	<i>No options defined</i>	-	-
Patient Demographics Consumer	<i>No options defined</i>	-	-

Actor	Option Name	Optionality	Vol & Section
Order Placer	<i>No options defined</i>	-	-
Department System Scheduler/Order Filler	<i>No options defined</i>	-	-
Acquisition Modality	Patient Based Worklist Query (see Note 2)	R	EYECARE TF- 2: 4.1
	Broad Worklist Query (see Note 2)	R	EYECARE TF- 2: 4.1
	Eye Care Image Option	C See Section 7.2.2	EYECARE TF- 2: 4.2
	Encapsulated PDF Option for Evidence Documents	C See Section 7.2.2	EYECARE TF- 2: 4.2
	Eye Care Measurement Option	C See Section 7.2.2	EYECARE TF- 2: 4.2
Acquisition Modality Importer	Patient Based Worklist Query (see Note 2)	R	EYECARE TF- 2: 4.1
	Acquisition Modality Importer Storage	R	EYECARE TF- 2: 4.2
	Broad Worklist Query (see Note 2)	R	EYECARE TF- 2: 4.1
Evidence Creator	<i>No options defined</i>	-	-
Image Manager/ Image Archive	<i>No options defined</i>	-	-
Image Display	<i>No options defined</i>	-	-

Note 1: The options in the table are defined in the transitions referenced in the Vol & Section column. For example, the Patient Based Worklist Query is referenced to section EYECARE TF-2: 4:1. If you look at Table 7.1-1, you can see that this transaction belongs to Query Modality Worklist.

Note 2: The Radiology TF requires that the Acquisition Modality support at least one of the Worklist Query choices (i.e. Patient and Broad). Eye Care requires support for both options for the Acquisition Modality and Acquisition Modality Importer.

The Acquisition Modality and Image Manager/ Image Archive will likely support a variety of DICOM SOP Classes. It is expected that this level of optionality will be documented by a reference in the IHE Integration Statement (see appendix C).

### 7.2.1 Implementation of Transactions Defined in Advanced Eye Care Integration Profile

Implementations that support B-EYECARE may also support transactions and/or options defined in A-EYECARE such as DICOM Storage Commandment, the Stereo Relationship Option, etc. See Tables 3.1-1 and 3.2-1 for the complete list of transactions possible for implementation.

## 7.2.2 Acquisition Modalities Storage Options

The DICOM Standard defines certain Image Storage SOP Classes that are applicable to EYECARE Acquisition Modalities, such as Ophthalmic 8 bit Photography Image Storage, Ophthalmic Tomography Image Storage, etc., see EYECARE TF- 2: 4.2.5 for the complete list of SOP Classes. Acquisition Modalities for whom a DICOM Image SOP Class is defined are recommended to support the Eye Care Image Option. The Acquisition Modality Actor may support the associated Storage SOP Classes or support the DICOM Secondary Capture and/or DICOM Encapsulated PDF SOP Classes.

Image SOP Classes for certain Acquisition Modalities are yet to be defined in DICOM. For these Acquisition Modalities, the support of the Encapsulated PDF Option for Evidence Documents does comply with the Basic Eye Care Workflow Profile. However, once the applicable SOP classes are defined by DICOM, then it is recommended by the Basic Eye Care Workflow Profile that the Acquisition Modalities support the Eye Care Image Option with the appropriate DICOM SOP Class. The Encapsulated PDF Option may be supported as an addition to the appropriate DICOM SOP Class.

Note 1: For example, in IHE Year 1 there was not a DICOM SOP class defined for Ophthalmic Tomography, therefore, these types of Acquisition Modalities only had the capability to support the Encapsulated PDF Option for Evidence Documents. But in IHE Year 2 DICOM has defined such a SOP Class, therefore, they are recommended to support the approved DICOM SOP Class and additionally they may also support the Encapsulated PDF Option.

Note 2: The DICOM standard does not define use of a specific version of PDF when encapsulated PDF is used. This may result in incorrect display of reports when using a different PDF version of software from that which was used to create the files. Other issues arise when using only PDF with pixel data as the files are large and there may be difficulties with display. IHE Eye Care Technical Framework defines specific versions required for support; see EYECARE TF-2: 4.2.

The DICOM Standard defines certain Measurement Storage SOP Classes that are applicable to EYECARE Acquisition Modalities, such as Lensometry Measurement Storage, Subjective Refraction Measurement Storage, etc., see EYECARE TF-2:4.2.8 for the complete list of SOP Classes.

Acquisition Modalities for whom a DICOM Measurement SOP Class is defined are recommended to support the Eye Care Measurement Option in order to comply with the Basic Eye Care Workflow Profile.

## 7.2.3 Acquisition Modality Importer Storage

The DICOM Standard defines certain Image and Measurement Storage SOP Classes that are applicable to eye care instruments such as ophthalmic photography, ultrasound, ophthalmic tomography images, refractive measurements, etc., see EYECARE TF-2:4.2.5 for the complete list of SOP Classes.

Acquisition Modality Actors for whom a DICOM Image Storage SOP Class or a DICOM Measurement Storage SOP Class is defined are recommended to support the associated DICOM SOP Class. However, the Acquisition Modality Importer Actor may support the associated Storage SOP Classes or support the DICOM Secondary Capture and/or DICOM Encapsulated PDF SOP Classes. See EYECARE TF- 2:4.2.11 for the complete specification.

### 7.3 Basic Eye Care Workflow Process Flow

The Eye Care administrative process flow is shown in Figure 7.3-1. For comparison with radiology, see RAD TF- 1:3.3. The functionality of those data flows is specified within the specific transactions invoked by the EYECARE TF.

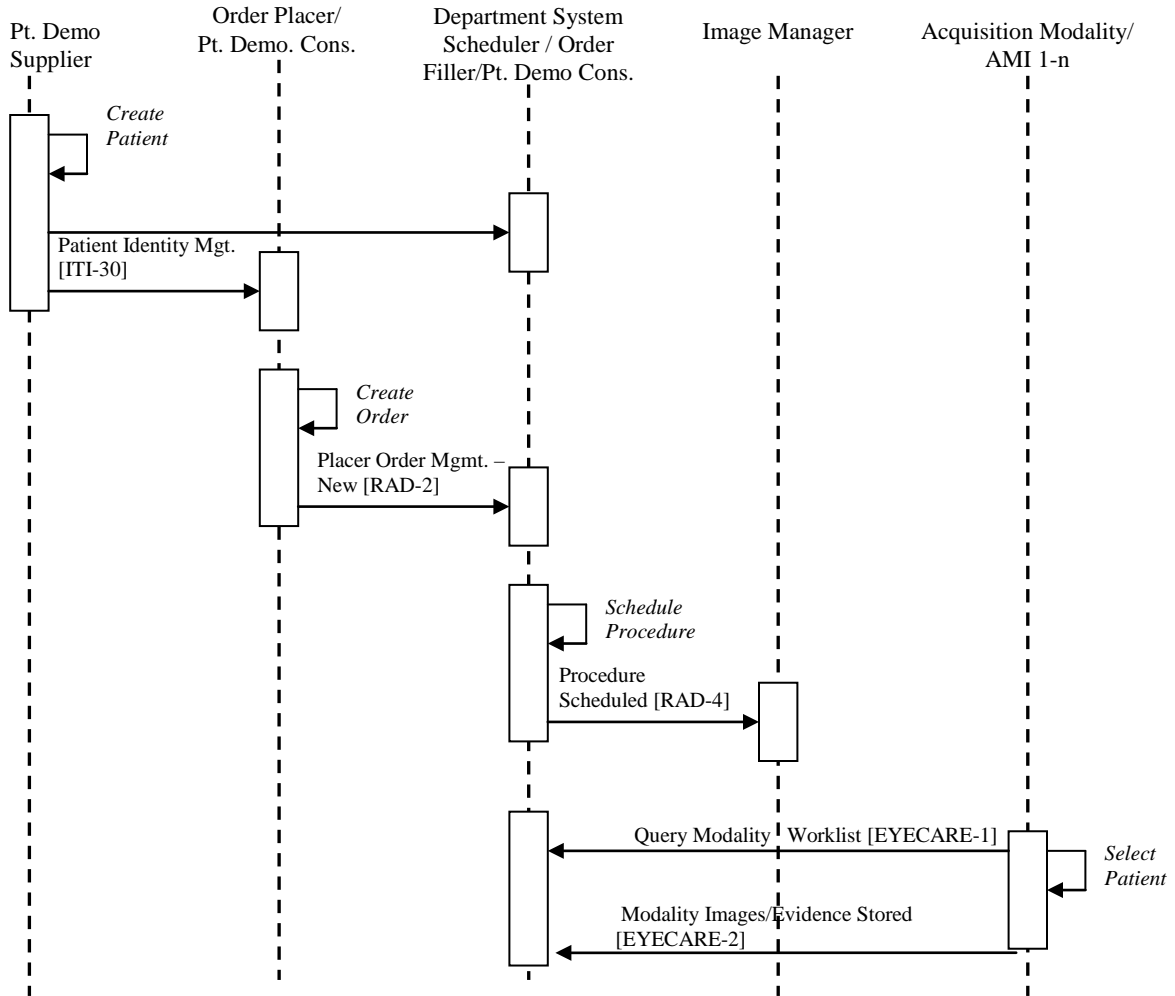

**Figure 7.3-1. Workflow: Administrative Process Flow**

The following should be noted in relation to the Administrative process flow:

- *Patient Registration:* The Patient demographics data is broadcast to several systems, including the Order Placer and the Department System Scheduler/Order Filler (DSS/OF). See ITI TF 1:14 for many detailed use case explanations.
- *Create Order:* The Order Placer and Order Filler are the repositories for all patient orders.

- *Schedule Procedure*: The DSS/OF associates the order with one or more Requested Procedures that have to be performed to satisfy the order. Each Requested Procedure prescribes a number of actions that have to be performed by Acquisition Modalities and Acquisition Modality Importers. Actions are specified in Scheduled Procedure Steps (SPS) based on timing and sequencing, and on modality. Scheduled Procedure Steps are scheduled, i.e., assigned a time slot and performing resource (modality), and are made available for Modality Worklist Query.
- *Query Modality Worklist*: The Modality Worklist (MWL) query may be broad (get a list of scheduled procedures from which one will be selected), or patient-specific (provided with sufficient query keys to get back the scheduled procedure for a single patient). Eye Care procedures may be performed on multiple Acquisition Modalities or Acquisition Modality Importers, therefore, multiple devices may perform the queries.
- *Select Patient*: In the event of a single SPS in the MWL response, a modality may optimize the Select Patient function to select that SPS without further explicit user action.
- *Perform Acquisition*: Each Modality may produce a variety of images and other evidence (visual fields, refractive and biometry information, etc.) that are stored to the Image Manager/Archive. The Image Manager/Archive must support all the object types as specified by the Eye Care Image Option, the Eye Care Measurement Option and the Encapsulated PDF Option (see EYECARE TF-2: 4.2).

### **7.3.1 Extension to Query Modality Worklist for Eye Care [EYECARE-1]**

#### **7.3.1.1 Issuer of Patient ID**

The Patient Demographics Supplier actor transmits information regarding the assigning authority (issuer) of the Patient ID to the DSS/OF Actor, which is defined in [ITI-30], see ITI TF-2b:3.30. However, [RAD-5] (see RAD TF- 2: 4.5), does not required the DICOM attribute “Issuer of Patient ID” be filled in by the DSS/OF actor if asked by the Acquisition Modality or Acquisition Modality Importer (AMI) during a Modality Worklist query. This extension requires support for this attribute, see EYECARE TF- 2: 4.1 for complete specifications.

A key feature in Eye Care is that patient identity is a critical issue for the Acquisition Modality itself, because of longitudinal data requirements. For example, visual field analyzers persistently store longitudinal data in order to perform glaucoma progression analysis. Ensuring that all the data comes from one patient, and that all data from that patient is used to calculate the progression, is essential.

Traditionally, many instruments have used the patient name and date of birth to determine the identity of patient records, because patient ID’s were not available from an electronic health record and were unreliable. As electronic health record systems become available to manage patient ID’s systematically, these are typically used as the unique key for the identity of the patient record. However, this is within the context of their own “namespace” of ID’s. In order for an acquisition modality to confidently determine the identity of its patient records based on the

Patient ID, it also must know this context. This can be provided by the “Issuer of Patient ID” attribute.

Note: When an Issuer of ID is provided to the acquisition modality, it should determine patient identity based on the (Issuer of Patient ID, Patient ID) combination, rather than patient name and date of birth. The acquisition modality should still provide patient reconciliation logic for legacy records.

## 7.4 Basic Eye Care Workflow Use Cases

This section describes the specific use cases and process flows defined for the Basic Eye Care Workflow Profile.

**Clinical Context:** B-EYECARE addresses three workflow scenarios, standalone eye care clinics, large eye care groups and hospital-based eye care departments. We understand that others scenarios exist, i.e. Eye care referrals, Tele-medicine, etc. However, they are not being formally addressed and will be considered in future versions.

Note: Even though not all clinical scenarios are being formally addressed, the defined workflow cases may actually apply to these scenarios. However, this has not been determined.

We are addressing scenarios expecting the patients to be registered and the procedures to be ordered. There are clinical scenarios where orders may not be placed. They will be addressed in future versions.

The following two examples show two typical scheduled workflows that may occur. They are very similar in the IHE transactions performed; however, the difference is whether a manual or automatic order was created for a procedure.

Note: For the purposes of this Technical Framework, the term "order" shall be construed in the most generic sense. The extent to which an order is treated as a healthcare provider's order shall be a function of legal jurisdiction. When the procedure involved is deemed not to require a healthcare provider's order, the "order" may be viewed simply as a requirement to preserve data integrity in the workflow.

### 7.4.1 Workflow Example with Manual Procedure Order

The patient has been created in a Patient Demographics Supplier actor, a healthcare provider has written a procedure order manually, and a procedure step has been scheduled. The technician uses the Acquisition Modality or Acquisition Modality Importer to query for a worklist. This may be either a patient query (using parameters to identify the patient uniquely), or a broad query (for all procedure steps scheduled for the modality). The modalities use the DICOM modality worklist service to query the DSS/OF, which responds with a worklist. This is displayed on the modality. The modality may then use the DICOM query/retrieve service to retrieve longitudinal data to display to the technician prior to the acquisition, or to display to the healthcare provider after the acquisition (for implicit post-processing involving longitudinal data). The technician selects the appropriate worklist item. The technician performs the acquisition based upon the scheduled protocol code identified in the worklist, or the technician may determine that the requested protocol code was insufficiently specific, and select a different code for acquiring the information. For example, a visual field may have been ordered and the code to convey the procedure and protocol is Visual Field. This code is not specific enough to choose the algorithm needed. Management of the performed procedure step is not specified in B-EYECARE; see A-EYECARE for explanation.

### 7.4.2 Workflow Where the Procedure Ordered is an Automatic Eye Care Order

There are often a number of procedures performed on patients when they arrive in the clinic, without need for healthcare provider orders. For example, an eye care order may be created automatically when a patient is scheduled for an eye exam, placing the patient's name and order information on the modality worklist of several different instruments in the eye care clinic. Examples may include a lensometer and an autorefractor, etc. In this scenario, not all of the orders are performed. For example, if the patient does not have glasses, no lensometry measurement is required.

The patient has been created in a Patient Demographics Supplier actor, and a number of automatic orders are generated by the Order Placer or DSS/OF (i.e., an automatic eye care order is placed). The technician uses the Acquisition Modality or Acquisition Modality Importer actor to query the DSS/OF for a worklist. This may be either a patient query (using parameters to uniquely identify the patient), or a broad query (for all procedure steps scheduled for the modality). This is displayed on the Acquisition Modality or Acquisition Modality Importer. At this time, the technician recognizes the automatic eye care order and therefore determines that he/she needs to select the appropriate protocol code and perform the acquisition. The technician performs an acquisition for the patient. When the technician selects to save the acquisition, the modality uses the DICOM storage service to store the acquisition data to the storage server. Additional acquisitions may occur as part of the performed procedure step, each resulting in a DICOM storage command. Management of the performed procedure step is not specified in B-EYECARE; see A-EYECARE for explanation.

Not all of the automatically generated orders will be performed. The DSS/OF is responsible to remove all unused worklist items that have not been performed on this patient. The triggering mechanism for removing these automatic orders from the device specific Acquisition Modality Worklist will be defined by the DSS/OF and configured for the specific needs of the clinic. This is outside the scope of IHE.

The above workflow may occur on many different modalities for which automatic orders were created in the clinic.

This scenario is more completely documented in Appendix A.3 Workflow Examples using Automatic Orders.

## 7.5 Workflow Concepts in Practice

The IHE “Real World” model for Workflow described above offers three major levels of control that can be used to customize a broad range of specific workflow situations:

- **Order:** A request for an Imaging Service
- **Requested Procedure:** Unit of work resulting in one report with associated codified, billable acts.
- **Scheduled and Performed Procedure Step:** the smallest unit of work in the workflow that is scheduled (work to do) and/or performed (work done).

The DSS/OF uses the Universal Service ID in each order that it receives to determine what specific Requested Procedures are needed, and for each Requested Procedure, what Procedure Steps need to be scheduled.

A departmental Procedure Plan may be used in the DSS/OF Actor to predefine Orders that may be requested from the eye care department. Generally these orders are defined in the Order Placer. Definitions will specify both the procedure code and the Scheduled Procedure Steps for each Requested Procedure.

The figure below defines an example of the breakdown of a “rule out glaucoma” Order.

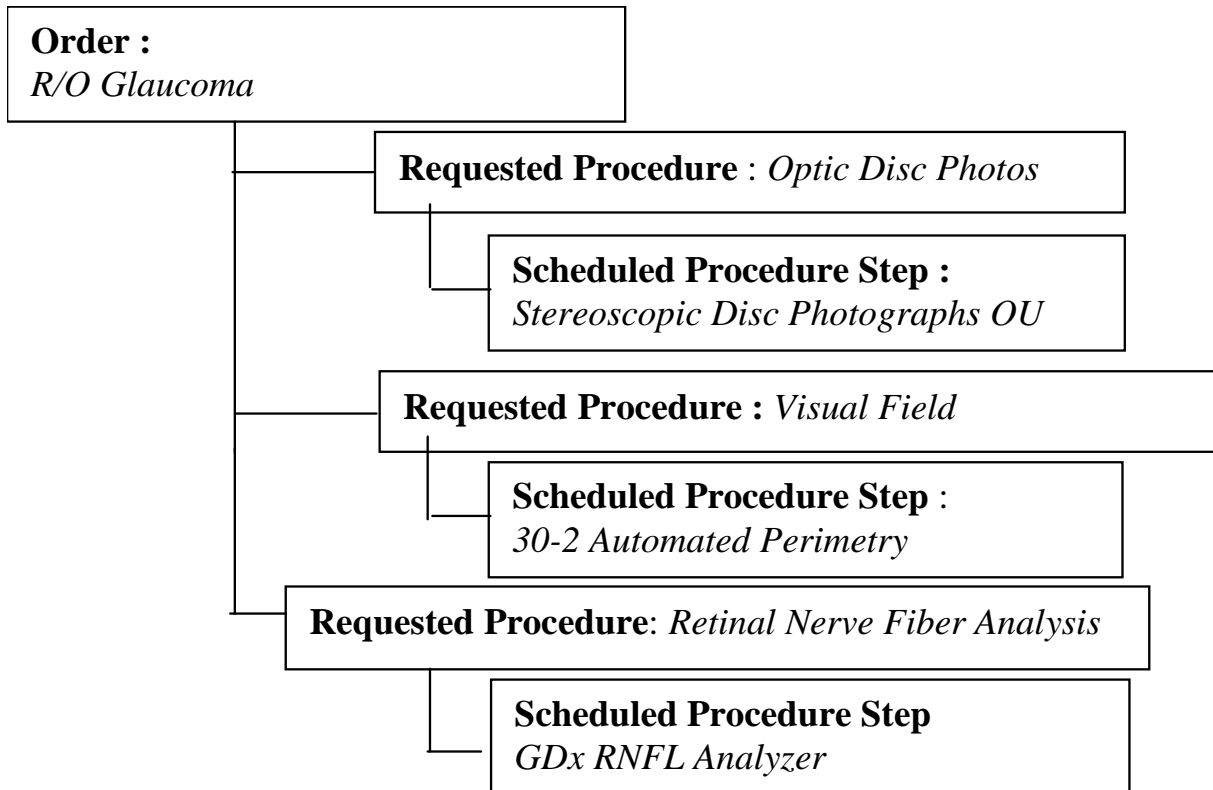

In this Procedure Plan, for this specific Order, three Requested Procedures are defined. Each Requested Procedure has been scheduled as a separate Scheduled Procedure Step, because the patient may have each one performed at a different time. In addition, more than one ophthalmologist may be involved in the interpretation of the Requested Procedures. This is the way this institution has decided to handle this Order. Another Institution may choose to require the same ophthalmologist to read some or all of the procedures. In that case, its Procedure Plan would define same Order to have a single Requested Procedure with two or three Scheduled Procedure Steps.

Many Orders processed in an Eye Care Department would have a simpler breakdown such as this Optic Disc Photos example.

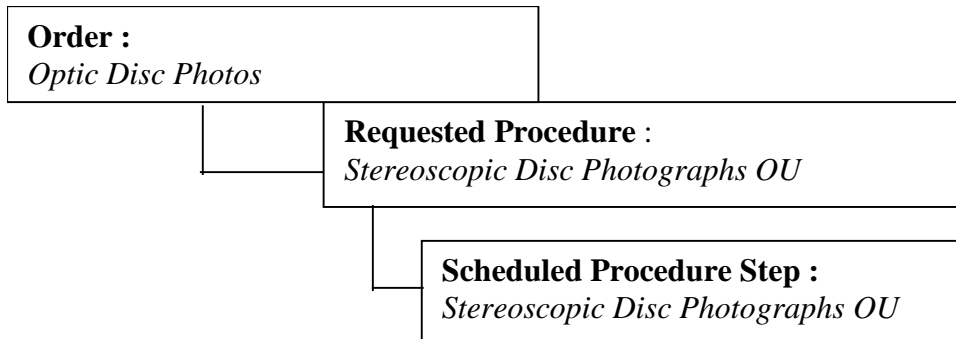

It should be noted that the three level Order breakdown has been defined in the IHE Scheduled Workflow so that any type of Order, from the simple case to the more complex case may be handled by the same workflow concepts, thus providing a general approach that can be easily customized by each department in the definition of its Procedure Plan.

In the IHE Scheduled Workflow, the **Accession Number identifies the Order**. The **Requested Procedure ID** distinguishes among Requested Procedures when an Order requires multiple Procedures. IHE sets a common meaning for these two terms to provide healthcare providers with a consistent and non-ambiguous access across different vendor products (RIS, PACS and Modalities).

Management of the performed procedure step is not specified in B-EYECARE; see A-EYECARE for explanation.

## 7.6 Patient Reconciliation Use Case

**Clinical Context:** Jane Smith is a patient within an eye care clinic. She gets married and her name has been changed to Jane Brown. Her medical records, images, measurements, etc. need updating to reflect her new patient demographics and/or patient ID. Products affected typically include Practice Management Systems (PMS), Electronic Medical Record systems, Archives, etc. The PMS is manually reconciled and the other systems are automatically synchronized with the changes.

**IHE Context:** This use case includes the Patient Update transaction; this transaction synchronizes the Patient Demographics Supplier, Order, Placer, Order Filler and Image Manager/Archive Actors. It is called Patient Reconciliation in IHE. The Order Filler is responsible for synchronizing the Image Manager related to patient demographics and IDs. This is accomplished by receiving the Patient Identity Mgt transaction [ITI-30] from the Patient Demographics Supplier and converting that transaction to Patient Update [RAD-12].

The figure below provides an example workflow for the reconciliation and assumes Jane Smith has already been registered; such as in Figure 7.6-1.

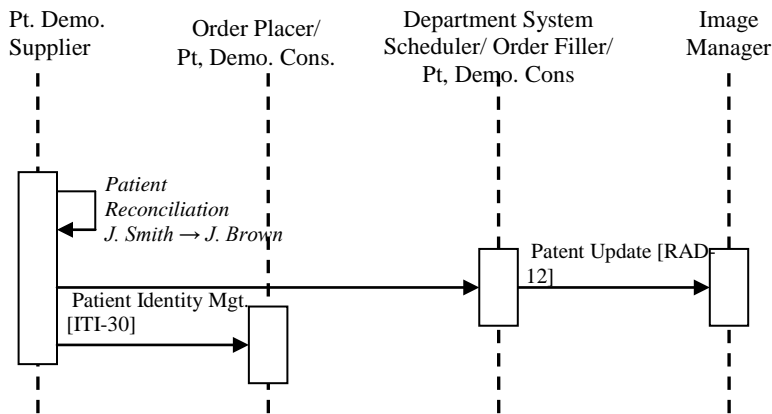

Figure 7.6-1. Patient Reconciliation

## 7.7 Workflow Use Cases

For detailed use cases beyond Basic Eye Care Workflow see section 3.6.

## X.4 <Profile Name> Security Considerations

No additional security considerations are required.

## **Glossary**

No terms added to glossary.

## Volume 2 - Transactions

*Modified section 4.2.6.2*

### 4.2.6.2 PDF Version Requirements

The DICOM standard does not define use of a specific version of PDF when encapsulated PDF is used. This may result in incorrect display of reports when using a different PDF version of software from that which was used to create the files. Common errors include blank or missing pages, missing or displaced graphics, or important changes in format, leading to risk for clinical error.

Another difficulty is that PDF files are very large when only pixel data is used in the file. This causes unacceptable clinical impacts such as very slow network transmission speeds. Pixel data PDFs also may cause unreadable display upon zooming in or out, allowing only small portions of a document to be viewed at one time, etc. When searchable PDF is used to store information as text the files are much smaller, solving many of the issues identified. The ability to search the text files is an additional critical benefit, allowing a clinician to locate specific information quickly.

ISO PDF based standards have been developed in order to address these issues. Acquisition Modality and Evidence Creator Actors **are recommended to shall** support ~~to~~ PDF/A ISO 19005-1. Document management – Electronic document file format for long-term preservation- Part 1: Use of PDF (PDF/A).

The PDF contents of the DICOM Encapsulated PDF objects **are recommended to shall** conform to PDF/A-1a (level A conformance to the PDF/A Part 1 standard). **This is intended** **The advantage of supporting PDF/A-1a is** to ensure that the rendered visual appearance of the document is reproducible across computer platforms and over the course of time, and that the document can be displayed in natural reading order on a mobile device (for example a PDA) or other devices in accordance with Section 508 of the US Rehabilitation Act.

The Image Display Actor shall conform to the PDF/A reader requirements for the display of DICOM Encapsulated PDF documents that are conformant to the PDF/A standard. This is intended to ensure the correct visual rendering of these documents.

**An individual profile may decide to require the PDF/A Standard, such as A-EYECARE.**

### 4.7.5.4 PDF Version Requirements

.....

ISO PDF based standards have been developed in order to address these issues. Report Creator Actors **are recommended to shall** support PDF/A ISO 19005-1. Document management – Electronic document file format for long-term preservation- Part 1: Use of PDF (PDF/A).

The PDF contents of the DICOM Encapsulated PDF objects **are recommended to shall** conform to PDF/A-1a (level A conformance to the PDF/A Part 1 standard). **This is intended** **The advantage of supporting PDF/A-1a is** to ensure that the rendered visual appearance of the document is reproducible across computer platforms and over the course of time, and that the document can be displayed in natural reading order on a mobile device (for example, a PDA) or other devices in accordance with Section 508 of the US Rehabilitation Act.

**An individual profile may decide to require the PDF/A Standard, such as A-EYECARE.**